

## ASSEMBLY OF TRANSFER

(See pages TF-32, 33)

### 1. INSTALL PLANETARY RING GEAR

(a) Install the planetary ring gear to the front case.

HINT: Make sure to install the ring gear in the correct direction.

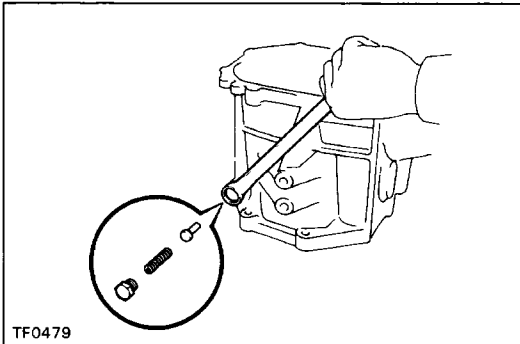

(b) Install the pin and spring.

(c) Apply liquid sealer to the plug.

**Sealant: Part No. 08833-00080, THREE BOND 1344, LOCTITE 242 or equivalent**

(d) Install and torque the plug.

**Torque: 19 N m (190 kgf -cm, 14 ft-lbf )**

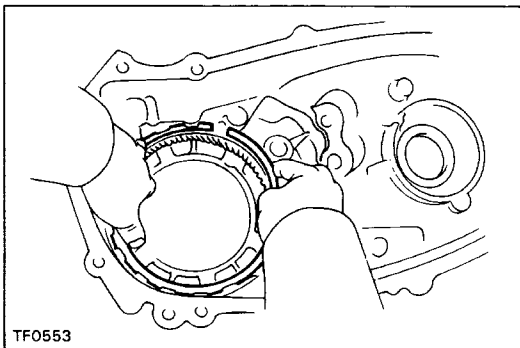

(e) Install the snap ring.

HINT: Be sure the end gap of the snap ring is not aligned with the upper side of the case.

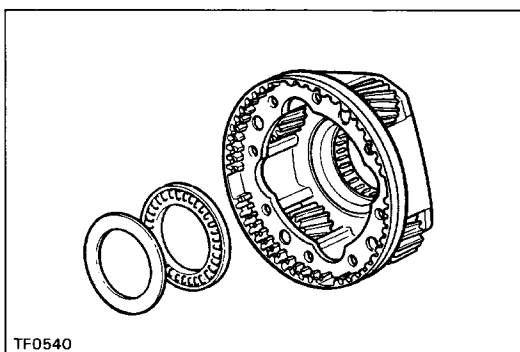

### 2. INSTALL INPUT SHAFT TO PLANETARY GEAR ASSEMBLY

(a) Apply gear oil to the thrust bearing and race.

(b) Install the race and thrust bearing.

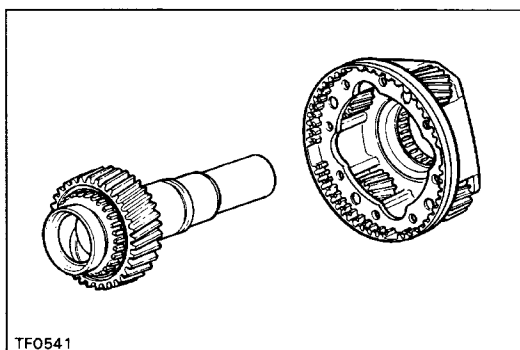

(c) Install the input shaft into the planetary gear assembly.

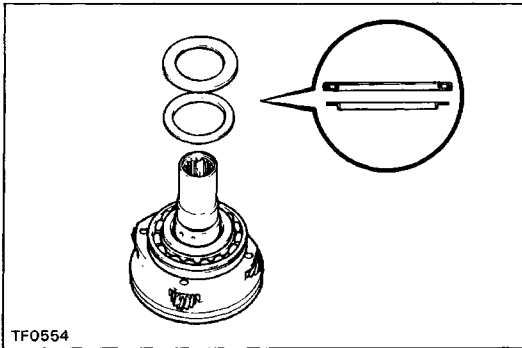

### 3. INSTALL THRUST BEARING AND INPUT SHAFT STOPPER

- (a) Apply gear oil to the thrust bearing and race.
- (b) Install the race and thrust bearing.

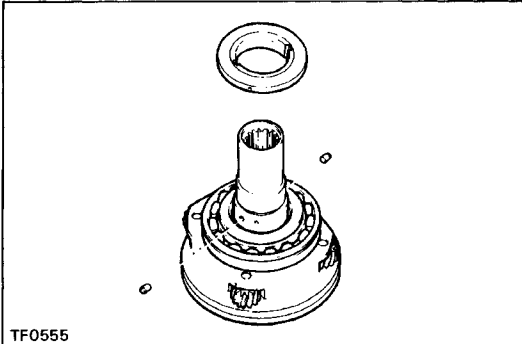

- (c) Install the two pins onto the input shaft.
- (d) Install the input shaft stopper.

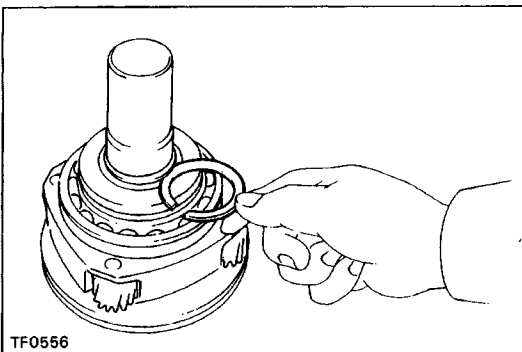

### 4. INSTALL SNAP RING

- (a) Select a snap ring that will allow 0.05 – 0.15 mm (0.0020 – 0.0059 in.) axial play.

Mark	Thickness mm (in.)	Mark	Thickness mm (in.)
A	2.10 – 2.15 (0.0827 – 0.0846)	L	2.60 – 2.65 (0.1024 – 0.1043)
B	2.15 – 2.20 (0.0846 – 0.0866)	M	2.65 – 2.70 (0.1043 – 0.1063)
C	2.20 – 2.25 (0.0866 – 0.0886)	N	2.70 – 2.75 (0.1063 – 0.1083)
D	2.25 – 2.30 (0.0886 – 0.0906)	P	2.75 – 2.80 (0.1083 – 0.1102)
E	2.30 – 2.35 (0.0906 – 0.0925)	Q	2.80 – 2.85 (0.1102 – 0.1122)
F	2.35 – 2.40 (0.0925 – 0.0945)	R	2.85 – 2.90 (0.1122 – 0.1142)
G	2.40 – 2.45 (0.0945 – 0.0965)	S	2.90 – 2.95 (0.1142 – 0.1161)
H	2.45 – 2.50 (0.0965 – 0.0984)	T	2.95 – 3.00 (0.1161 – 0.1181)
J	2.50 – 2.55 (0.0984 – 0.1004)	U	3.00 – 3.05 (0.1181 – 0.1201)
K	2.55 – 2.60 (0.1004 – 0.1024)		

- (b) Using snap ring pliers, install the snap ring.

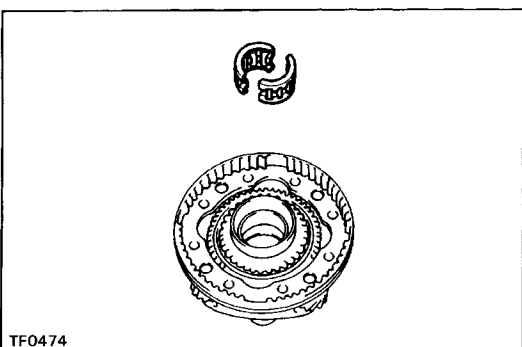
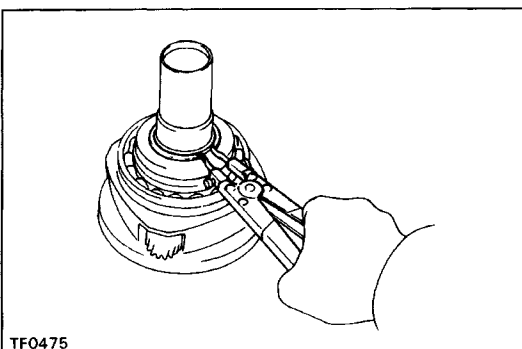

### 5. INSTALL NEEDLE ROLLER BEARING INTO INPUT SHAFT

- (a) Apply gear oil to the needle roller bearing.
- (b) Install the needle roller bearing into the input shaft.

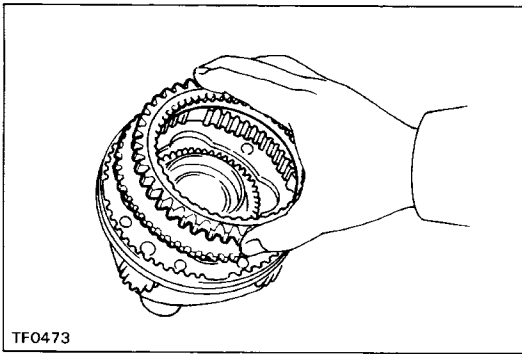

## 6. INSTALL LOW GEAR SPLINE PIECE

(a) Install the low gear spline piece to the planetary carrier.

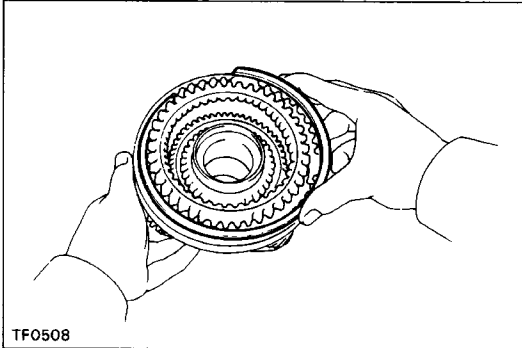

(b) Install the snap ring.

HINT: Be sure the end gap of the snap ring is not aligned with cutout portion of the planetary carrier.

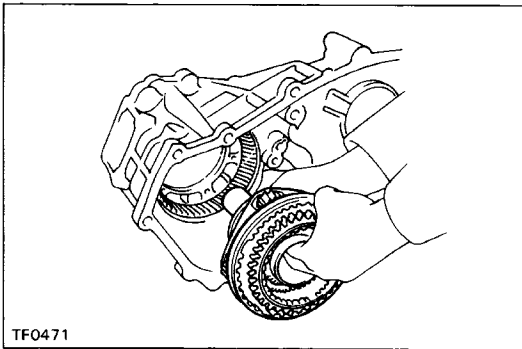

## 7. INSTALL PLANETARY GEAR ASSEMBLY TO FRONT CASE

(a) Install the planetary gear assembly with the input shaft.

HINT: If necessary, heat the front case to about 70°C (158°F).

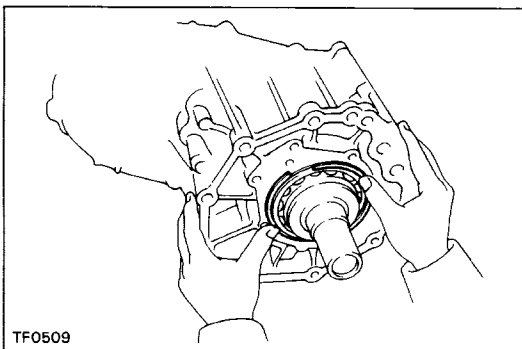

(b) Install the snap ring.

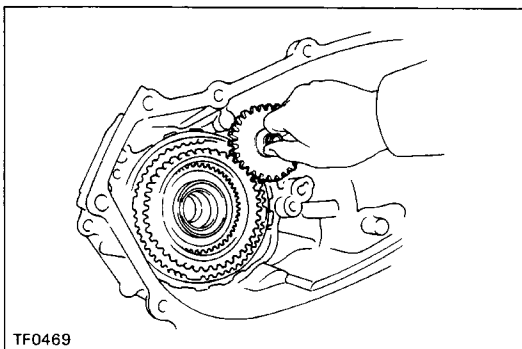

## 8. INSTALL OIL PUMP DRIVE GEAR

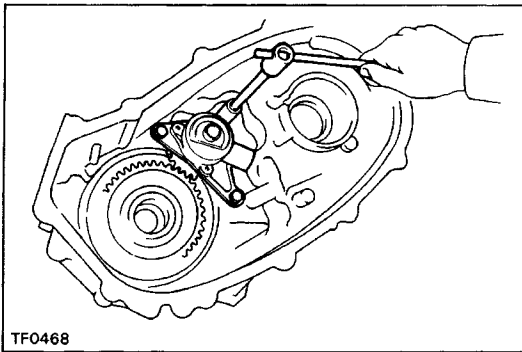
**9. INSTALL OIL PUMP BODY ASSEMBLY**

- (a) Install the oil pump body assembly.
- (b) Install and torque the three bolts.

**Torque: 11 N-m (115 kgf-cm, 8 ft-lbf)**

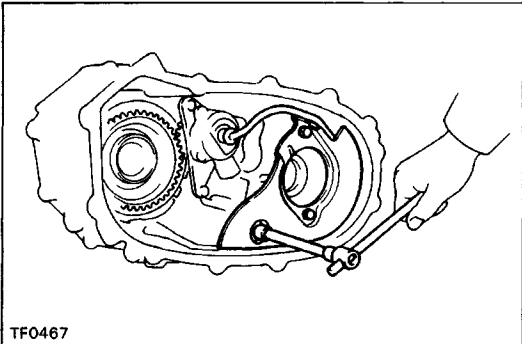
**10. INSTALL SEPARATER WITH OIL STRAINER**

- (a) Coat a new O-ring with gear oil and install it to the oil strainer pipe.
- (b) Install the separator with the oil strainer.
- (c) Install and torque the three bolts.

**Torque: 18 N-m (185 kgf-cm, 13 ft-lbf)**

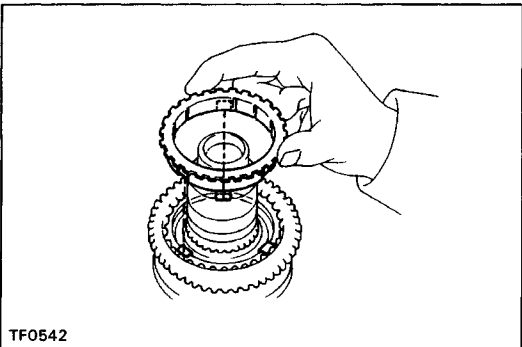
**11. INSTALL REAR OUTPUT SHAFT, DRIVEN SPROCKET AND CHAIN**

- (a) Apply MP grease to the synchronizer ring (R150F, G58).
- (b) Align the synchronizer ring slots with the shifting keys, and install it on the high and low clutch hub.

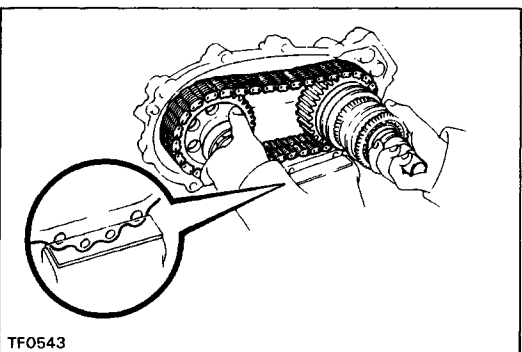

- (c) Assemble the rear output shaft, driven sprocket and chain.

- (d) Mount the rear case in the vise.

**NOTICE: Be careful not to damage the sealing surface.**

- (e) Using a plastic hammer, tap the rear case with pushing the rear output shaft and driven sprocket.

**HINT: If necessary, heat the rear case to about 70°C (158°F).**

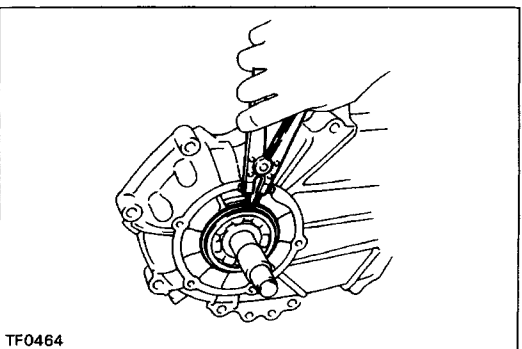

- (f) Using snap ring pliers, install the snap ring.

3VZ-E/R150F

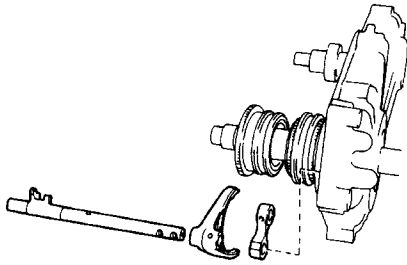

TF0463

## 12. INSTALL HIGH AND LOW FORK SHAFT, FORK AND STOPPER

(a) Place the high and low shift fork into the groove of the hub sleeve.

HINT: Make sure to install the shift fork in the correct direction.

(b) Install the fork shaft to the rear case through the shift fork and stopper.

22R-E/G58, A340F

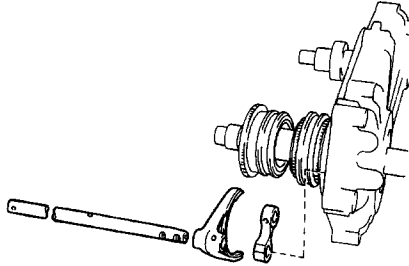

TF0616

## 13. INSTALL FRONT DRIVE FORK SHAFT, FORK AND SPRING

(a) Apply gear oil to the straight pin, and insert it into the case hole.

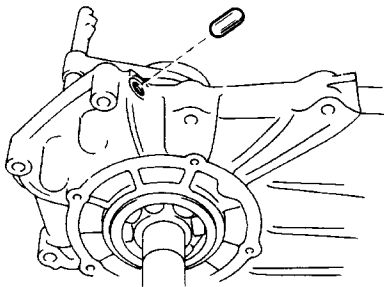

TF0462

(b) Place the front drive shift fork into the groove of the hub sleeve.

HINT: Make sure to install the shift fork in the correct direction.

(c) Install the spring to the fork shaft.

(d) Install the fork shaft to the rear case through the shift fork and stopper.

3VZ-E/R150F

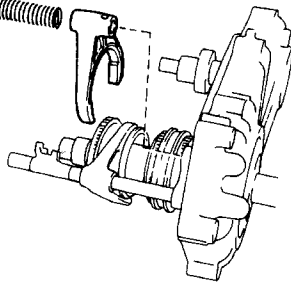

TF0461

22R-E/G58, A340F

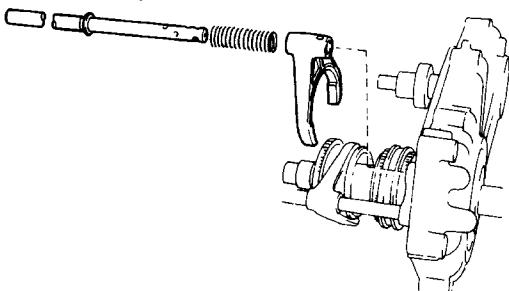

TF0623

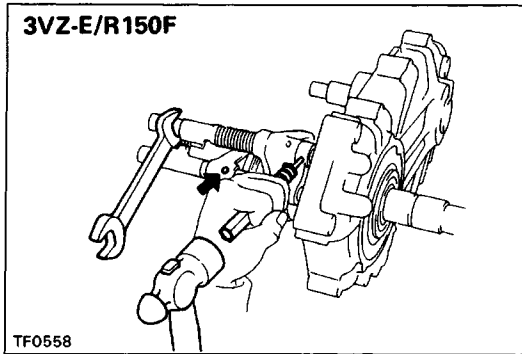

(e) Using a pin punch and hammer, drive in the two slotted spring pins.

HINT: When installing the pin in the front drive fork shaft, push the shaft towards the rear case and install the pin while the spring is compressed.

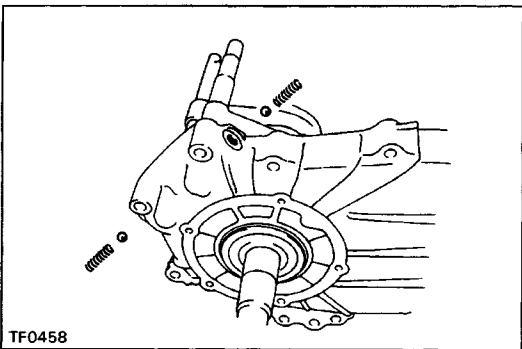
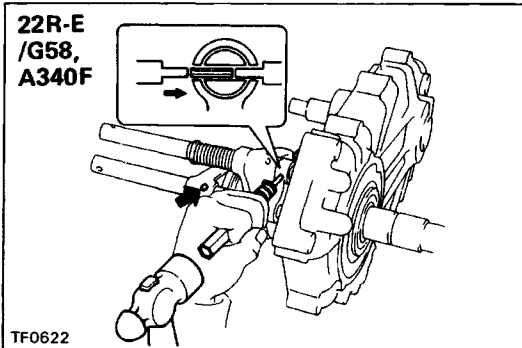

#### 14. INSTALL STRAIGHT SCREW PLUGS, SPRINGS AND LOCKING BALLS

(a) Install the ball and spring into the both holes.

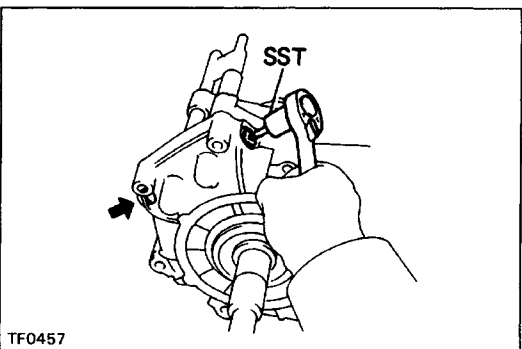

(b) Apply liquid sealer to the plugs.

**Sealant: Part No. 08833-00080, THREE BOND 1344, LOCTITE 242 or equivalent**

(c) Using SST, install and torque the two screws.

SST 09313-30021

**Torque: 19 N-m (190 kgf-cm, 14 ft-lbf)**

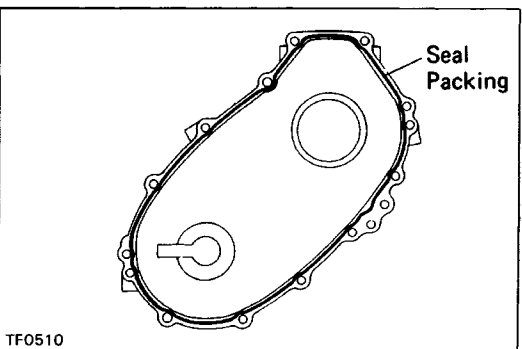

#### 15. ASSEMBLE FRONT CASE AND REAR CASE

(a) Apply seal packing to the rear case as shown in the figure.

**Seal packing: Part No. 08826-00090, THREE BOND 1281 or equivalent**

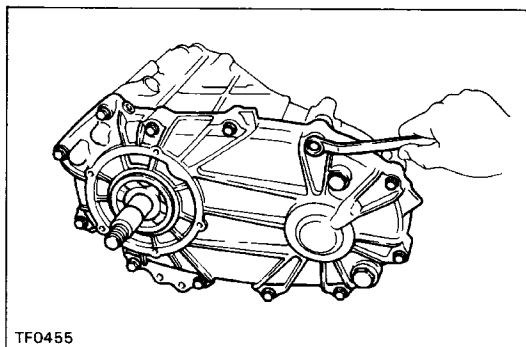

TF0455

(b) Shift the high and low hub sleeve to low side (rear side).

(c) Assemble the front case and rear case.

(d) Install and torque the twelve bolts.

**Torque: 37 N-m (380 kgf-cm, 27 ft-lbf)**

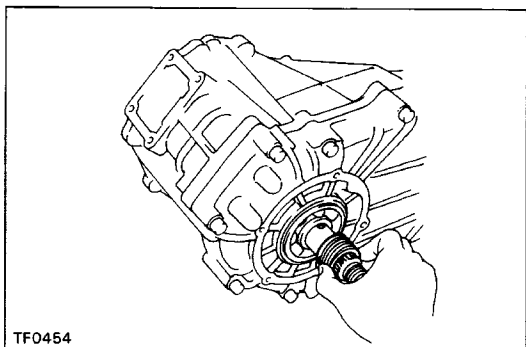

TF0454

#### 16. INSTALL SPEEDOMETER DRIVE GEAR

(a) Install the ball on the rear output shaft.

(b) Install the speedometer drive gear.

**HINT:** Make sure to install the speedometer drive gear in the correct direction.

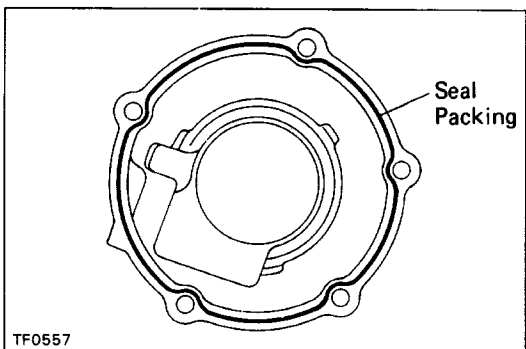

TF0557

#### 17. INSTALL EXTENSION HOUSING

(a) Apply seal packing to the extension housing as shown in the figure.

**Seal packing: Part No. 08826-00090, THREE BOND 1281 or equivalent**

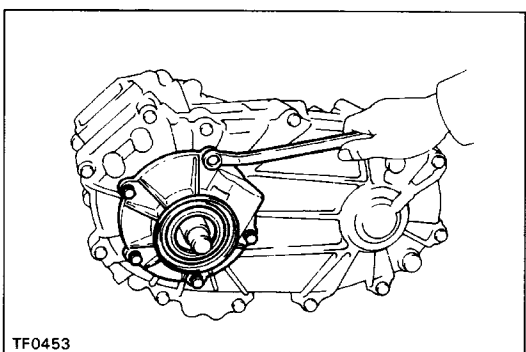

TF0453

(b) Install the extension housing to the rear case.

(c) Apply liquid sealer to the bolts.

**Sealant: Part No. 08833-00080, THREE BOND 1344, LOCTITE 242 or equivalent**

(d) Install and torque the five bolts.

**Torque: 11 N-m (115 kgf-cm, 8 ft-lbf )**

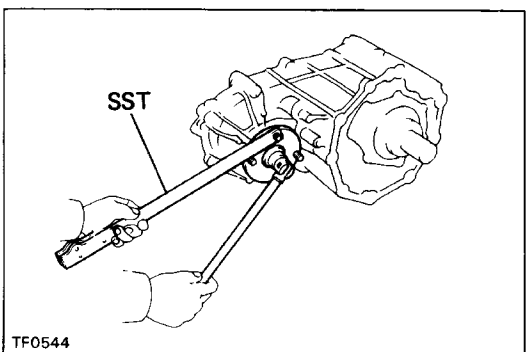

TF0544

#### 18. INSTALL FRONT COMPANION FLANGE

**HINT:** Front companion flange bolts are silver.

(a) Apply gear oil to the companion flange inner surface.

(b) Install the front companion flange to the driven sprocket shaft.

(c) Using SST to hold the flange, install the companion flange lock nut.

**SST 09330-00021**

**Torque: 118 N-m (1,200 kgf-cm, 87 ft-lbf)**

(d) Stake the lock nut.

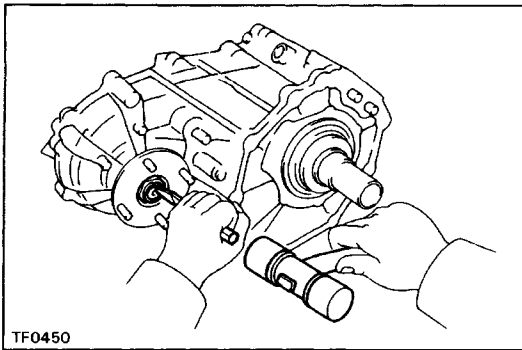
**19. INSTALL REAR COMPANION FLANGE**

HINT: Rear companion flange bolts are black.

Install the rear companion flange in the same way as the front companion flange.

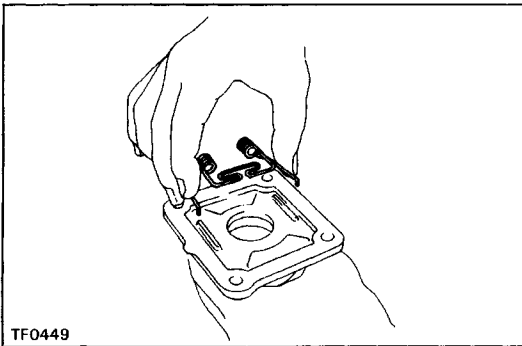
**20.-1 (3VZ-E/R 150F)****INSTALL CONTROL RETAINER**

(a) Install the select return spring to the control retainer.

(b) Remove the gasket and install a new one to the control retainer.

(c) Install the control retainer.

(d) Install and torque the four bolts.

**Torque: 18 N-m (185 kgf-cm, 13 ft-lbf)**

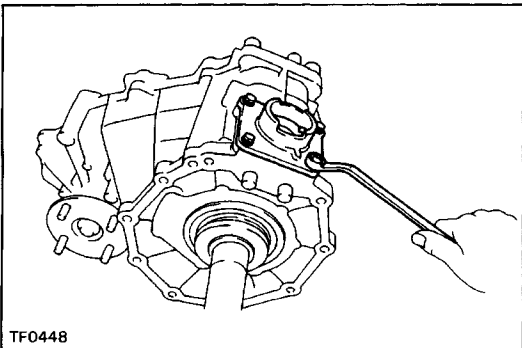
**20.-2 (22R-E/G58, A340F)****INSTALL UPPER COVER AND OIL DEFLECTOR**

(a) Remove the gasket and install a new one to the case cover.

(b) Install the upper cover and oil deflector.

(c) Install and torque the four bolts.

**Torque: 18 N-m (185 kgf-cm, 13 ft-lbf)**

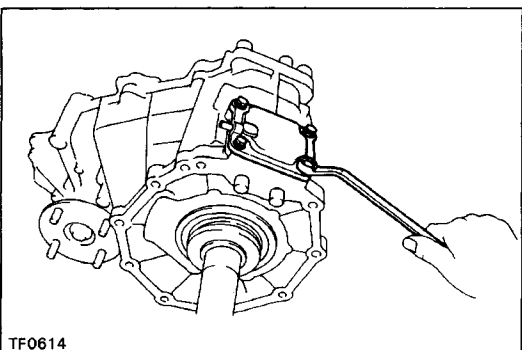
**21. INSTALL FRONT RETAINER**

(a) Remove the gasket and install a new one to the front retainer.

(b) Install the front retainer.

(c) Apply liquid sealer to the bolts.

**Sealant: Part No. 08833-00080, THREE BOND 1344,  
LOCTITE 242 or equivalent**

(d) Install and torque the seven bolts.

**Torque: 11 N m (115 kgf-cm, 8 ft-lbf)**

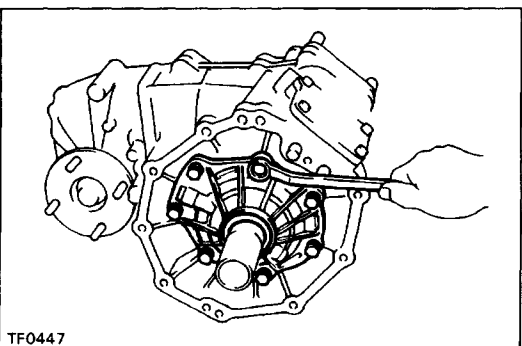

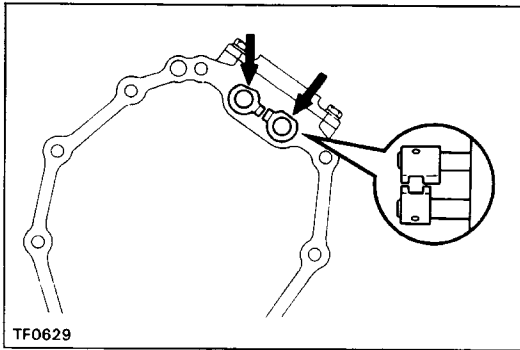

**22. (22R-E1G58, A340F)****INSTALL SHIFT GEAR HEAD NO. 1 AND NO.2**

- (a) Install two shift gear heads.
- (b) Using a pin punch and hammer, drive in the two slotted spring pins.

**23. CHECK FOLLOWING ITEMS:**

- (a) Check to see that the input shaft and output shafts rotate smoothly.
- (b) Check to see that shifting can be made smoothly to all positions.

**24. INSTALL TRANSFER INDICATOR SWITCH**

**Torque: 37 N-m (380 kgf-cm, 27 ft-lbf)**

**25. INSTALL NO. 1 SPEED SENSOR**

- (a) Install No.1 speed sensor.
- (b) Install and torque the bolt.

**Torque: 11 N-m (115 kgf-cm, 8 ft-lbf)**

**26. (22R-E/ 340F)****INSTALL TRANSFER L4 AND NEUTRAL POSITION SWITCH**

**Torque: 37 N-m (380 kgf-cm, 27 ft-lbf)**