

Rear Output Shaft Assembly COMPONENTS

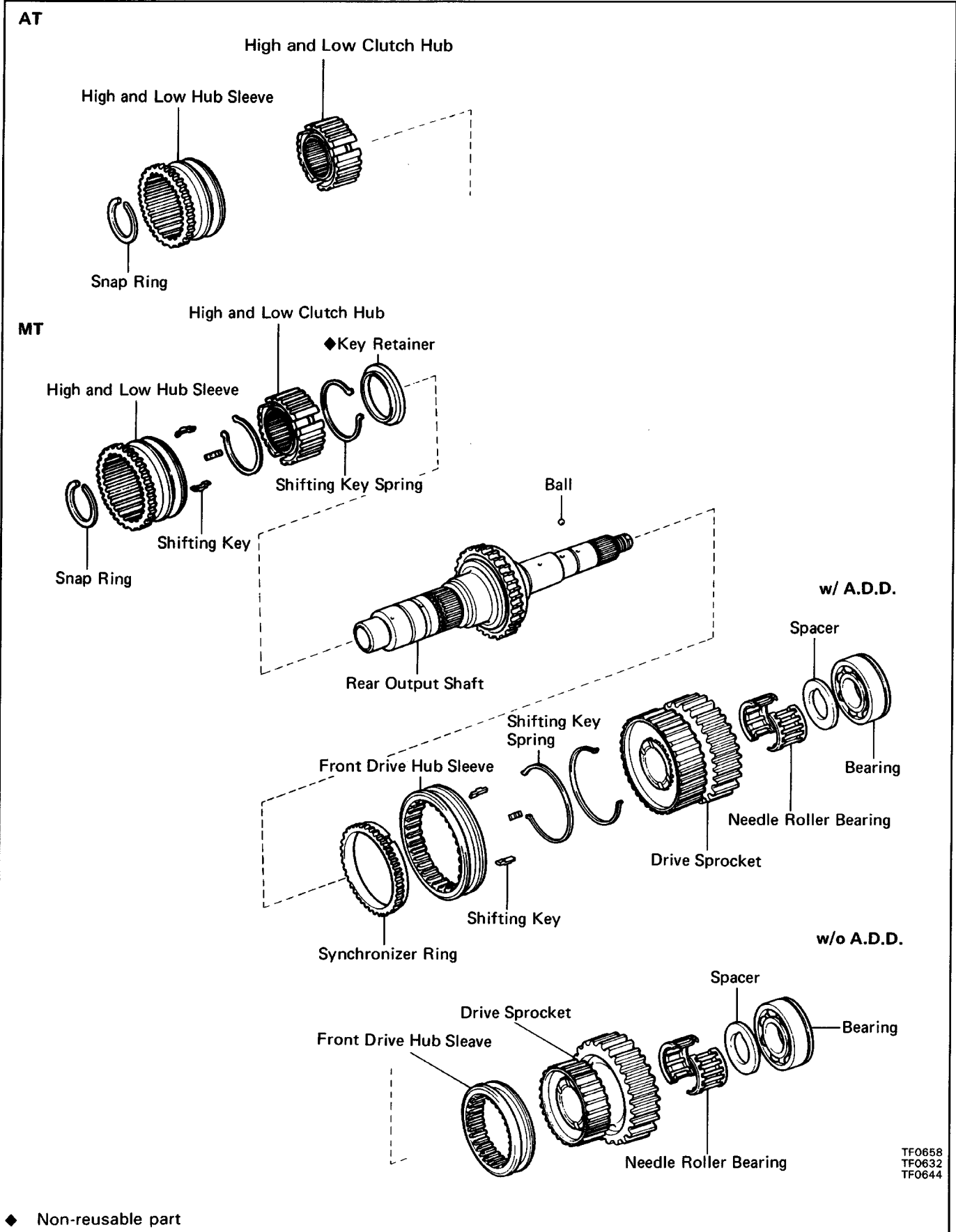

TF0658
TF0632
TF0644

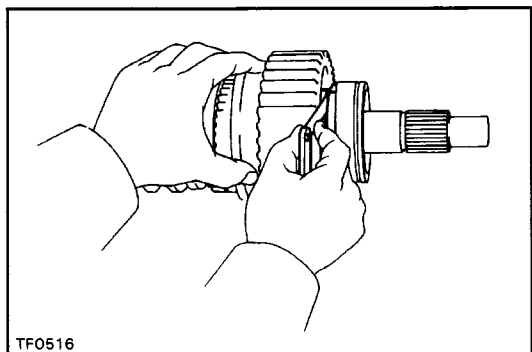

TF0516

DISASSEMBLY OF REAR OUTPUT SHAFT ASSEMBLY

1. MEASURE DRIVE SPROCKET THRUST CLEARANCE

Using a feeler gauge, measure the drive sprocket thrust clearance.

**Standard clearance: 0.10 – 0.25 mm
(0.0039 – 0.0098 in.)**

Maximum clearance: 0.25 mm (0.0098 in.)

If the clearance exceeds the limit, replace the drive sprocket.

2.-1 (MT)

REMOVE HIGH AND LOW HUB SLEEVE ASSEMBLY

- (a) Using snap ring pliers, remove the snap ring.
- (b) Remove the hub sleeve and shifting keys.
- (c) Using a press, remove the clutch hub, key springs and key retainer.

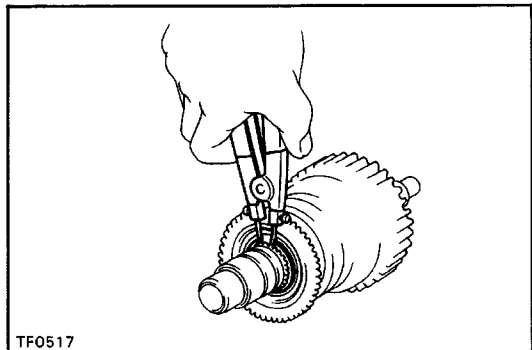

TF0517

2.-2 (AT)

REMOVE HIGH AND LOW HUB SLEEVE ASSEMBLY

- (a) Using snap ring pliers, remove the snap ring.
- (b) Remove the hub sleeve.
- (c) Using a press, remove the clutch hub.

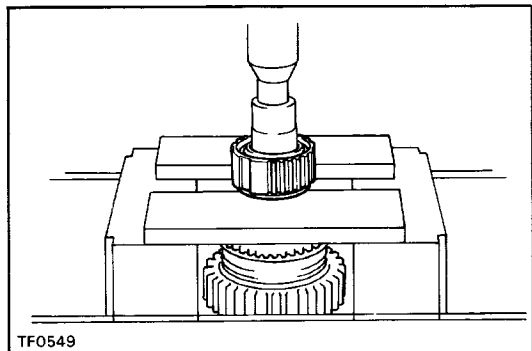

TF0549

3.-1 (w/ A.D.D.)

REMOVE REAR BEARING, SPACER AND DRIVE SPROCKET WITH FRONT DRIVE HUB SLEEVE ASSEMBLY

- (a) Using SST and a press, remove the bearing.
- SST 09950-00020

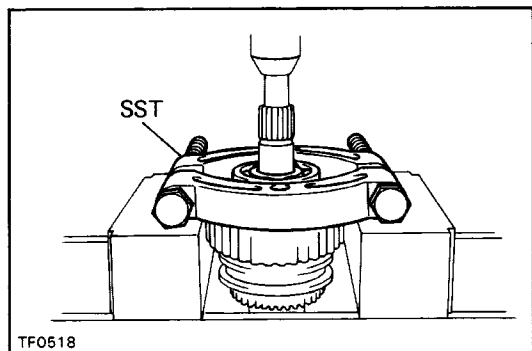

TF0518

- (b) Remove the spacer and ball.
- (c) Remove the drive sprocket with front drive hub and hub sleeve.
- (d) Remove the needle roller bearing.
- (e) Remove the synchronizer ring.

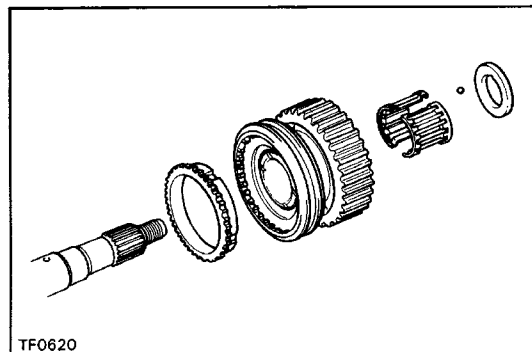

TF0620

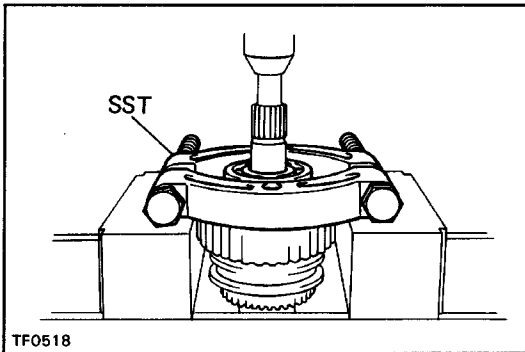

**3.-2 (w/o A.D.D.)
REMOVE REAR BEARING, SPACER AND DRIVE
SPROCKET WITH FRONT DRIVE HUB SLEEVE
ASSEMBLY**

(a) Using SST and a press, remove the bearing.
SST 09950-00020

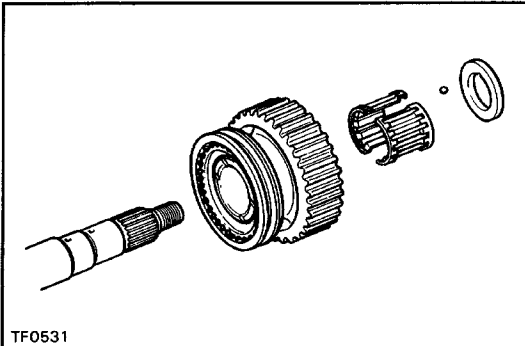

- (b) Remove the spacer and ball.
- (c) Remove the drive sprocket with front drive hub and hub sleeve.
- (d) Remove the needle roller bearing.

**4. (w/ A.D.D.)
REMOVE SHIFTING KEYS AND KEY SPRINGS FROM
FRONT DRIVE HUB ASSEMBLY**

Using screwdriver, remove the two shifting key springs and three shifting keys.

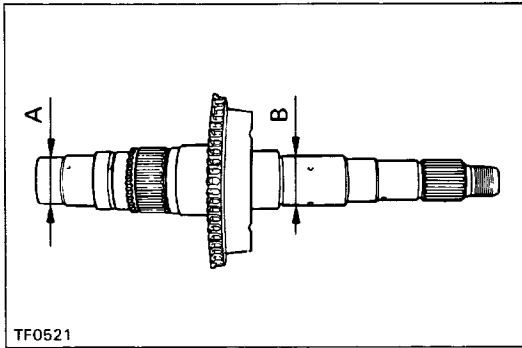

INSPECTION OF REAR OUTPUT SHAFT ASSEMBLY

1. INSPECT REAR OUTPUT SHAFT

Using a micrometer, measure the outer diameter of the rear output shaft journal surface.

Minimum diameter:

Part A 27.98 mm (1.1016 in.)

B 36.98 mm (1.4559 in.)

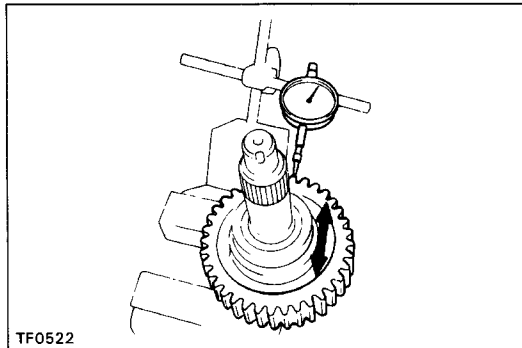

2. CHECK OIL CLEARANCE OF DRIVE SPROCKET

Using a dial indicator, measure the oil clearance between the sprocket and shaft with the needle roller bearing installed.

**Standard clearance: 0.010 – 0.055 mm
(0.0004 – 0.0022 in.)**

Maximum clearance: 0.055 mm (0.022 in.)

If the clearance exceeds the limit, replace the drive sprocket, rear output shaft or needle roller bearing.

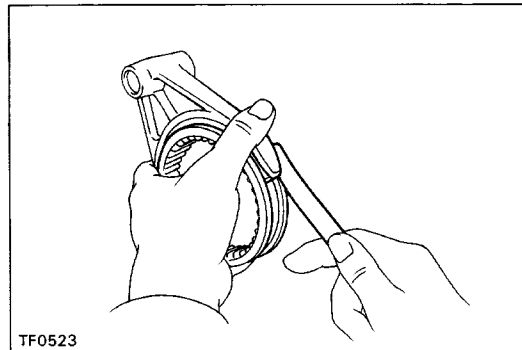

3. MEASURE CLEARANCE OF FRONT DRIVE SHIFT FORK AND HUB SLEEVE

Using a feeler gauge, measure the clearance between the front drive shift fork and hub sleeve.

Maximum clearance: 1.0 mm (0.039 in.)

If the clearance exceeds the limit, replace the shift fork or hub sleeve.

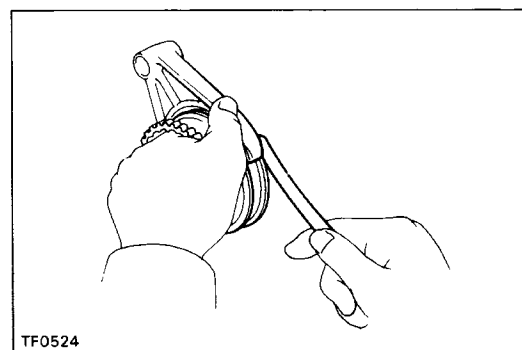

4. MEASURE CLEARANCE OF HIGH AND LOW SHIFT FORK AND HUB SLEEVE

Using a feeler gauge, measure the clearance between the high and low shift fork and hub sleeve.

Maximum clearance: 1.0 mm (0.039 in.)

If the clearance exceeds the limit, replace the shift fork or hub sleeve.

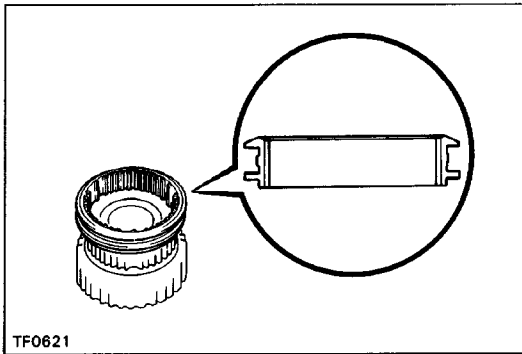

ASSEMBLY OF REAR OUTPUT SHAFT ASSEMBLY

1.-1 (w/ A.D.D.)

INSTALL FRONT DRIVE CLUTCH HUB AND HUB SLEEVE

(a) Install the front drive hub sleeve onto the clutch hub.

HINT: Make sure to install the hub sleeve in the correct direction.

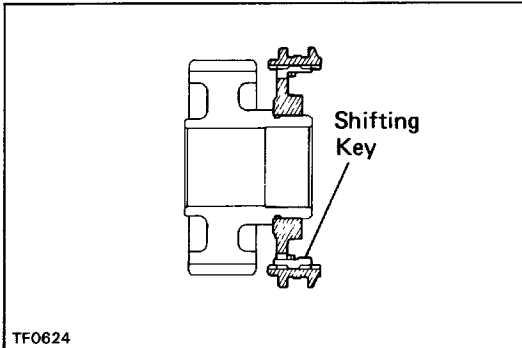

(b) Install the shifting keys and springs.

NOTICE: Install the key springs positioned so that their end gaps are not in line.

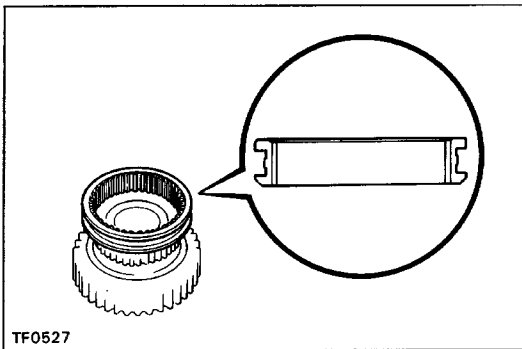

1.-2 (w/o A.D.D.)

INSTALL FRONT DRIVE CLUTCH HUB AND HUB SLEEVE

Install the front drive hub sleeve onto the clutch hub.

HINT: Make sure to install the hub sleeve in the correct direction.

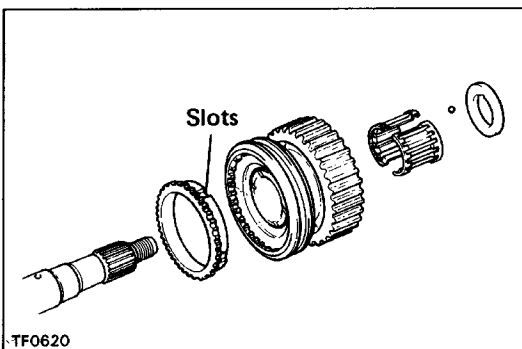

2.-1 (w/ A.D.D.)

INSTALL DRIVE SPROCKET WITH FRONT DRIVE HUB SLEEVE ASSEMBLY, SPACER AND REAR BEARING

(a) Apply gear oil to the shaft and needle roller bearing.

(b) Install the synchronizer ring.

(c) Install the needle roller bearing in the drive sprocket.

(d) Install the drive sprocket with the front drive hub sleeve.

(e) Place the synchronizer ring on the gear and align the ring slots with the shifting keys.

(f) Install the spacer to align it with the ball.

(g) Using SST and a press, install the rear bearing with the outer race snap ring groove toward the rear.

SST 09316-60010 (09316-00010, 09316-00070)

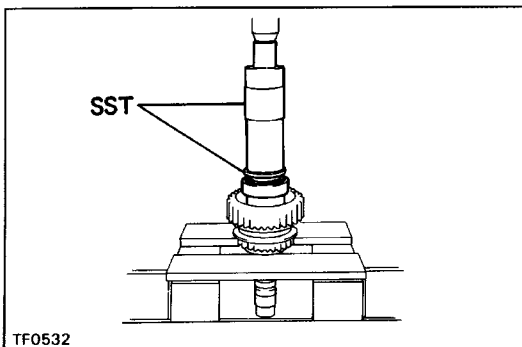

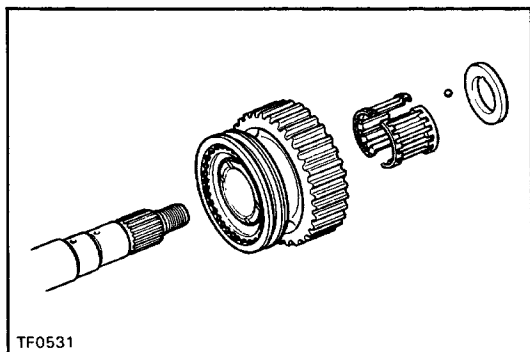
**2.-2 (w/o A.D.D.)****INSTALL DRIVE SPROCKET WITH FRONT DRIVE HUB SLEEVE ASSEMBLY, SPACER AND REAR BEARING**

- (a) Apply gear oil to the shaft and needle roller bearing.
- (b) Install the needle roller bearing in the drive sprocket.
- (c) Install the drive sprocket with the front drive hub sleeve.
- (d) Install the spacer to align it with the ball.

TF0531

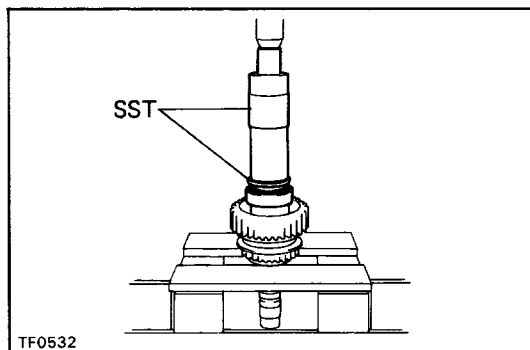

- (e) Using SST and a press, install the rear bearing with the outer race snap ring groove toward the rear.
SST 09316-60010 (09316-00010, 09316-00070)

TF0532

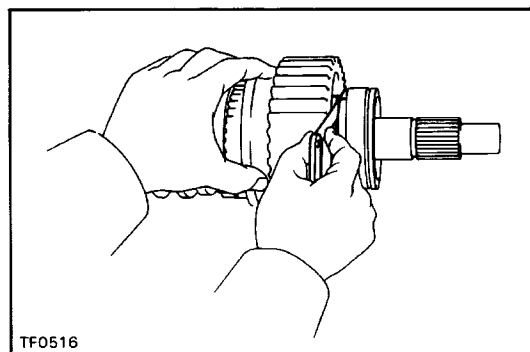
**3. MEASURE DRIVE SPROCKET THRUST CLEARANCE**

Using a feeler gauge, measure the drive sprocket thrust clearance.

Standard clearance: 0.10 – 0.25 mm
(0.0039 – 0.0098 in.)

TF0516

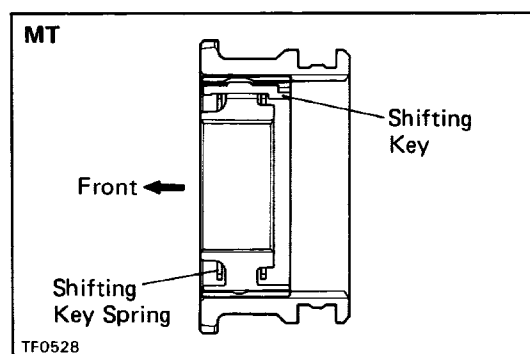
**4.-1 (MT)****INSERT HIGH AND LOW CLUTCH HUB INTO HUB SLEEVE**

- (a) Install the clutch hub and shifting keys to the hub sleeve.
- (b) Install the shifting key springs under the shifting keys.

NOTICE: Install the key springs positioned so that their end gaps are not in line.

TF0528

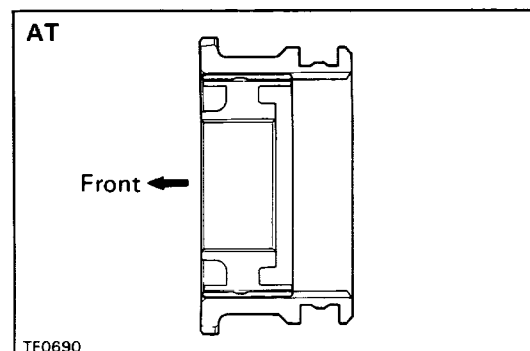
**4.-2 (AT)****INSERT HIGH AND LOW CLUTCH HUB INTO HUB SLEEVE**

Install the clutch hub to the hub sleeve.

TF0690

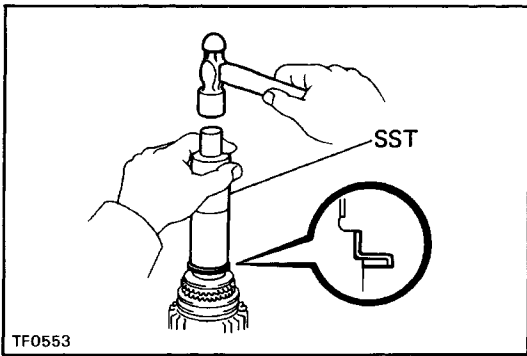

5.-1 (MT)

INSTALL HIGH AND LOW HUB SLEEVE ASSEMBLY

(a) Using SST and a hammer, drive in a new key retainer.

SST 09316-60010 (09316-00010)

NOTICE: Be careful not to deform or damage the key retainer.

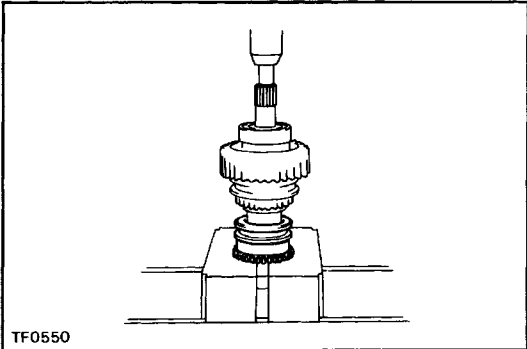

(b) Using a press, install the high and low hub sleeve assembly.

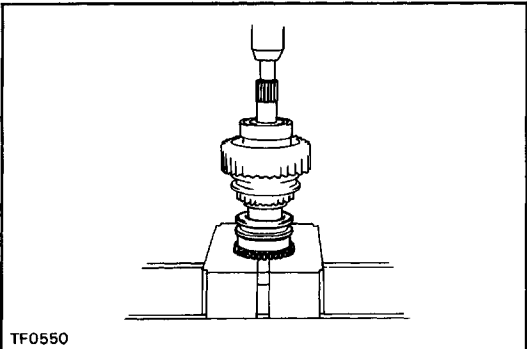

5.-2 (AT)

INSTALL HIGH AND LOW HUB SLEEVE ASSEMBLY

Using a press, install the high and low hub sleeve assembly.

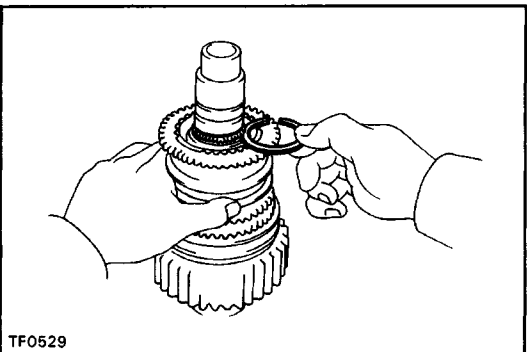

6. INSTALL SNAP RING

(a) Select a snap ring that will allow minimum axial play.

Mark	Thickness mm (in.)
A	2.10 - 2.15 (0.0827 - 0.0846)
B	2.15 - 2.20 (0.0846 - 0.0866)
C	2.20 - 2.25 (0.0866 - 0.0886)
D	2.25 - 2.30 (0.0886 - 0.0906)
E	2.30 - 2.35 (0.0906 - 0.0925)
F	2.35 - 2.40 (0.0925 - 0.0945)
G	2.40 - 2.45 (0.0945 - 0.0965)
H	2.45 - 2.50 (0.0965 - 0.0984)
J	2.50 - 2.55 (0.0984 - 0.1004)
K	2.00 - 2.05 (0.0787 - 0.0807)
L	2.05 - 2.10 (0.0807 - 0.0827)

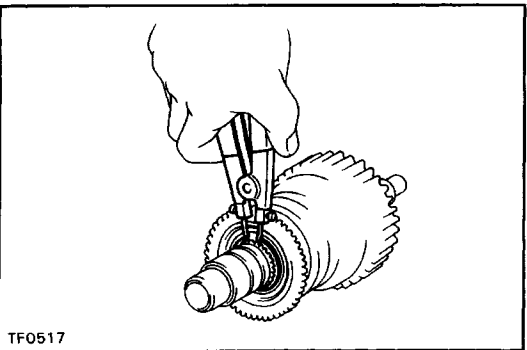

(b) Using snap ring pliers, install the snap ring.