

Counter Gear Assembly and Reverse Idler Gear COMPONENTS

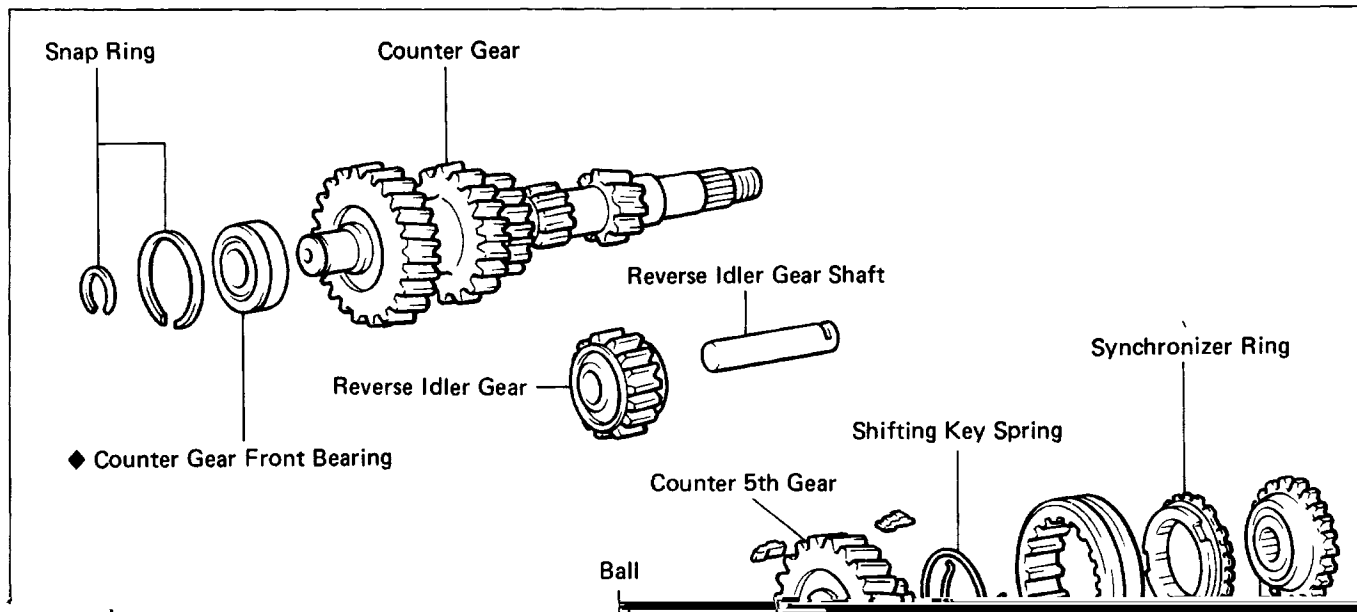

INSPECTION OF COUNTER GEAR

1. INSPECT FIFTH GEAR OIL CLEARANCE

(a) Install the spacer, counter 5th gear and needle roller bearings.

(b) Using a dial indicator, measure the counter 5th gear oil clearance.

Standard clearance: 0.015 – 0.068 mm

(0.0006 – 0.0027 in.)

Maximum clearance: 0.16 mm (0.0063 in.)

If the clearance exceeds the maximum, replace the gear

2. REMOVE HUB SLEEVE NO.3. SHIFTING KEYS AND SPRINGS FROM COUNTER FIFTH GEAR

Using a screwdriver, remove the three shifting keys and two springs from counter 5th gear

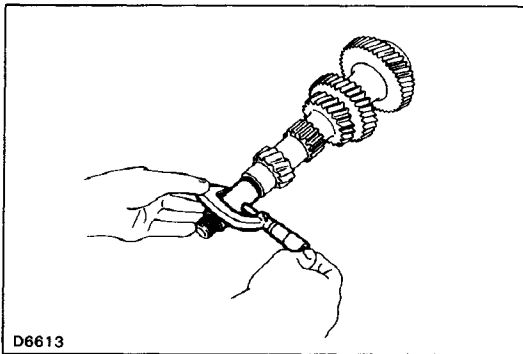

3. INSPECT COUNTER GEAR

Using a micrometer, measure the outer diameter of the counter gear journal.

Minimum diameter: 27.860 mm (1.0968 in.)

If the outer diameter exceeds the minimum, replace the counter gear.

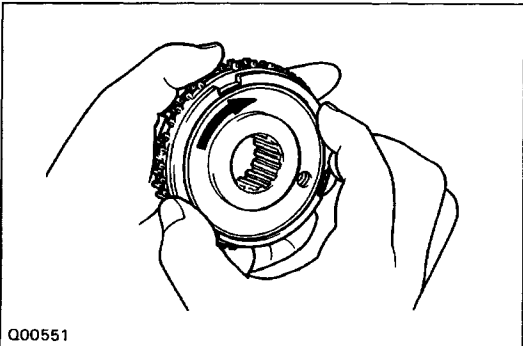

4. INSPECT SYNCHRONIZER RINGS

(a) Turn the ring and push it in to check the braking action.

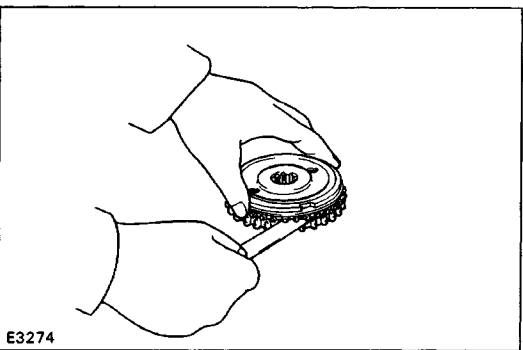

(b) Using a feeler gauge, measure the clearance between the synchronizer ring back and the gear spline end.

Standard clearance: 0.8 – 1.6 mm

(0.031 – 0.063 in.)

Minimum clearance: 0.6 mm (0.024 in.)

If the clearance is less than the minimum, replace the synchronizer ring.

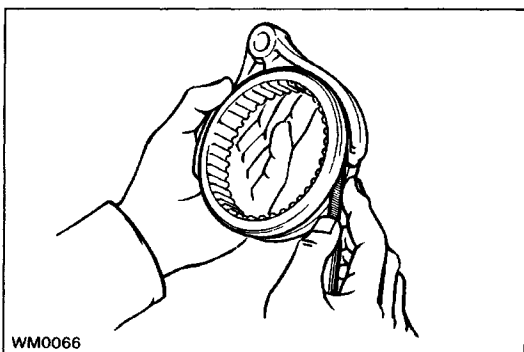

5. INSPECT CLEARANCE OF SHIFT FORKS AND HUB SLEEVES

Using a feeler-gauge, measure the clearance between the hub sleeve and shift fork.

Maximum clearance: 1.0 mm (0.039 in.)

If the clearance exceeds the maximum, replace the shift fork or hub sleeve.

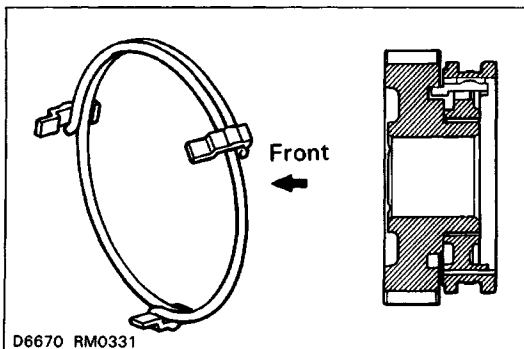

6. INSTALL HUB SLEEVE NO.3, SHIFTING KEYS AND SPRINGS TO COUNTER 5TH GEAR

(a) Install the counter 5th gear and shifting keys to the hub sleeve.

(b) Install the shifting key springs under the shifting keys.

NOTICE: Install the key springs positioned so that their end gaps are not in line.

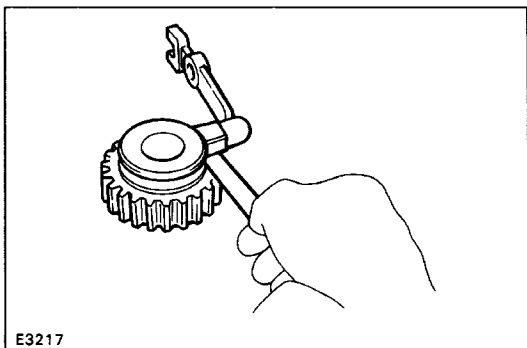

INSPECTION OF REVERSE IDLER GEAR

1. INSPECT CLEARANCE OF REVERSE IDLER GEAR AND SHIFT ARM SHOE

Using a feeler gauge, measure the clearance between the reverse idler gear and shift arm shoe.

**Standard clearance: 0.05 – 0.25 mm
(0.0020 – 0.098 in.)**

Maximum clearance: 0.5 mm (0.0197 in.)

If the clearance exceeds the maximum, replace the shift arm shoe or reverse idler gear.

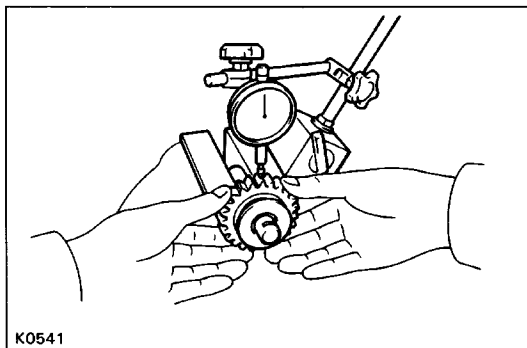

2. INSPECT REVERSE IDLER GEAR OIL CLEARANCE

Using a dial indicator, measure the reverse idler gear oil clearance.

**Standard clearance: 0.040 – 0.082 mm
(0.0016 – 0.032 in.)**

Maximum clearance: 0.13 mm (0.0051 in.)

If the clearance exceeds the maximum, replace the reverse idler gear or reverse idler gear shaft.

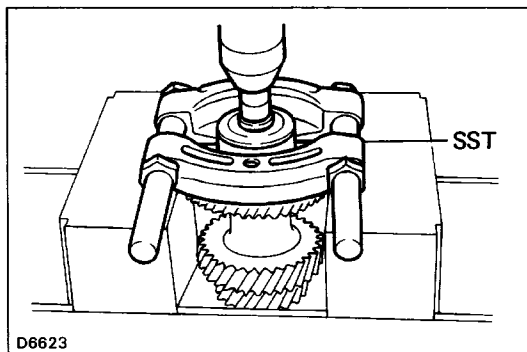

REPLACEMENT OF BEARING

IF NECESSARY, REPLACE COUNTER GEAR FRONT BEARING

- (a) Using a snap ring expander, remove the snap ring.
- (b) Using SST and a press, remove the bearing.
SST 09950-00020
- (c) Replace the side race.

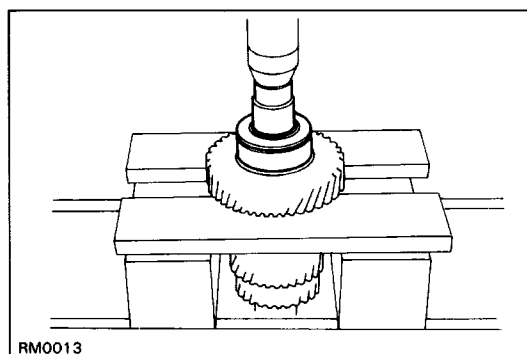

- (d) Using a 24 mm socket wrench, press in the bearing and inner race.

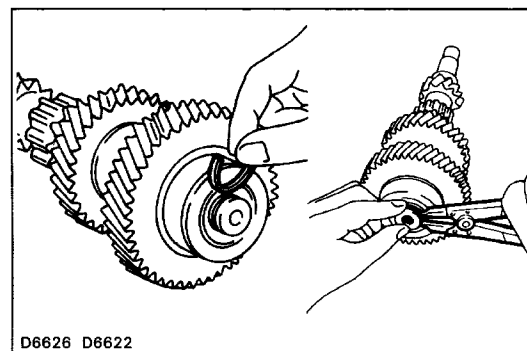

- (e) Select a snap ring that will allow minimum axial play and install it on the shaft.

Mark	Thickness mm (in.)
A	2.00 – 2.05 (0.0787 – 0.0807)
B	2.05 – 2.10 (0.0807 – 0.0827)
C	2.10 – 2.15 (0.0827 – 0.0846)
D	2.15 – 2.20 (0.0846 – 0.0866)
E	2.20 – 2.25 (0.0866 – 0.0886)