

FUEL PUMP SYSTEM CIRCUIT

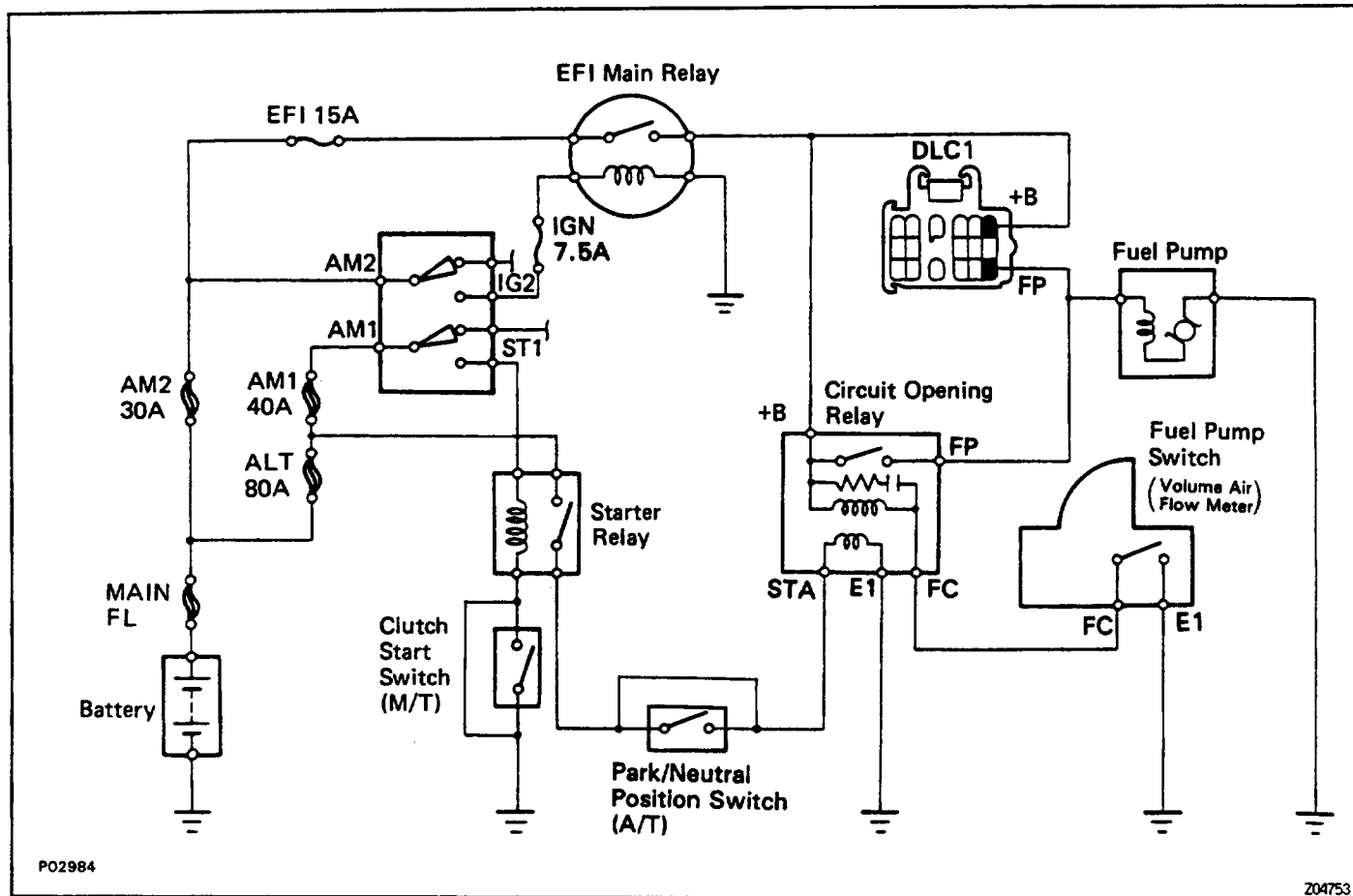

P02984

Z04753

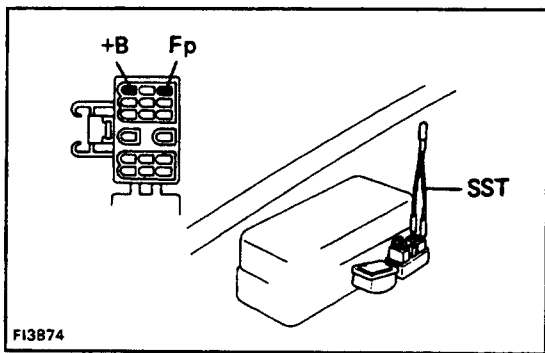

F13874

ON-VEHICLE INSPECTION

1. CHECK FUEL PUMP OPERATION

- (a) Turn the ignition switch ON.
HINT: Do not start the engine.
- (b) Using SST, connect terminals Fp and +B of the DLC1.
SST 09843-18020
HINT: The DLC1 is located near the No. 2 relay block.

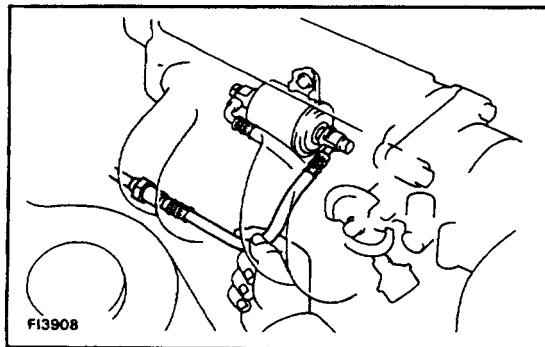

F13908

- (c) Check that there is pressure in the fuel inlet hose.
HINT: At this time, you will hear fuel return noise from the pressure regulator.
- (d) Remove SST from the DLC1.
- (e) Turn the ignition switch OFF.

If there is no pressure, check the following parts:

- Fusible links
- Fuses (EFI 15A, IGN 7.5A)
- EFI main relay

- Circuit opening relay
- Fuel pump
- Wiring connections

2. CHECK FUEL PRESSURE

- Check that the battery voltage is above 12 volts.
- Disconnect negative (-) terminal cable from of the battery.

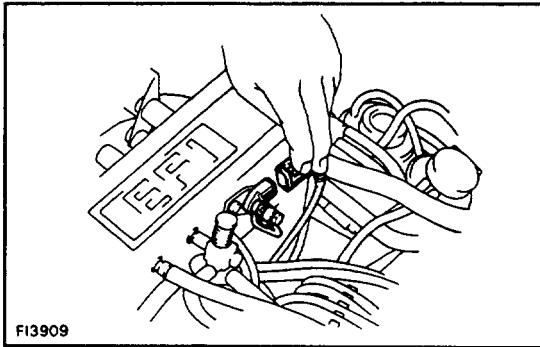

- Disconnect the wiring connector from the cold start injector.

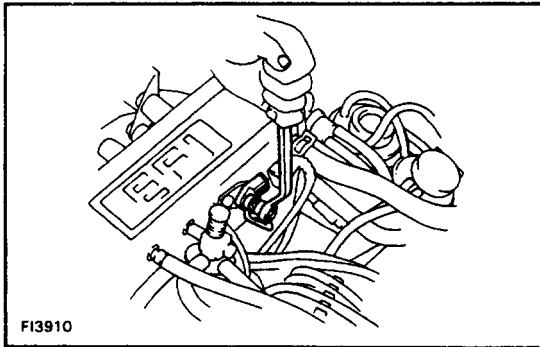

- Put a suitable container or shop towel under the cold start injector pipe.
- Slowly loosen the union bolts of the cold start injector pipe and remove the bolts, cold start injector pipe and 4 gaskets.
- Drain the fuel from the delivery pipe.

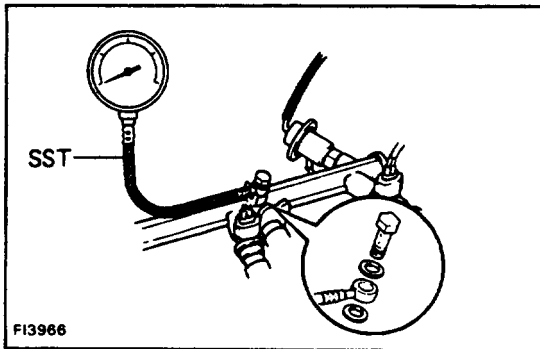

- Install a gasket, SST, another gasket and union bolt to the delivery pipe as shown in the illustration.
SST 09268-45012
- Wipe off any splattered gasoline.

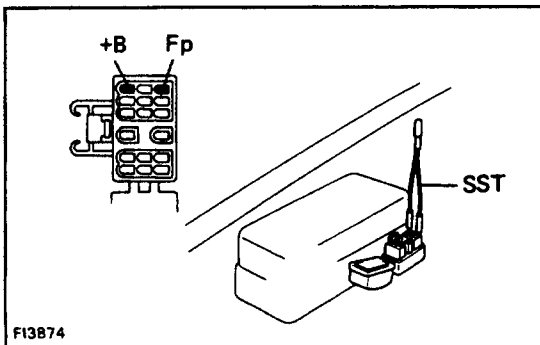

- Reconnect the negative (-) terminal cable to the battery.
- Using SST, connect terminals Fp and +B of the DLC1.
SST 09843-18020

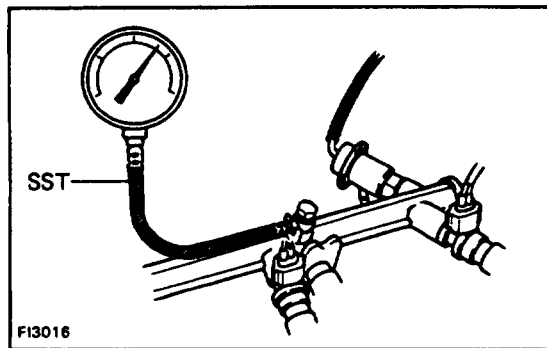

(k) Turn the ignition switch ON.

(l) Measure the fuel pressure.

Fuel pressure:

265–304 kPa (2.7–3.1 kgf/cm², 38–44 psi)

If high, replace the pressure regulator.

If low, check the following parts:

- Fuel hoses and connections
- Fuel pump
- Fuel filter
- Pressure regulator

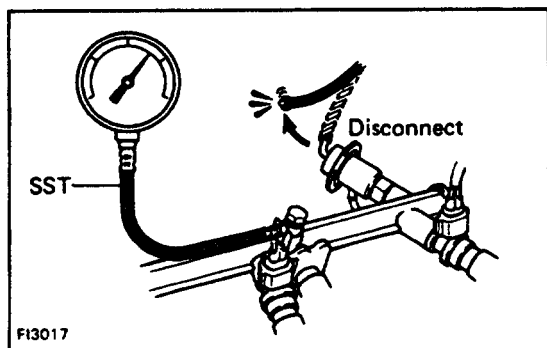

(m) Remove SST from the DLC1.

(n) Start the engine.

(o) Disconnect the vacuum hose from the pressure regulator and plug it closed.

(p) Measure the fuel pressure at idling.

Fuel pressure:

265–304 kPa (2.7–3.1 kgf/cm², 38–44 psi)

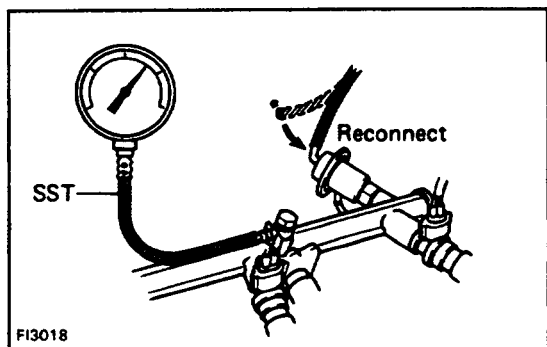

(q) Reconnect the vacuum hose to the pressure regulator.

(r) Measure the fuel pressure at idling.

Fuel pressure:

226–265 kPa (2.3–2.6 kgf/cm², 33–37 psi)

If not within the specified pressure, check the vacuum hose and pressure regulator.

(s) Stop the engine. Check that the fuel pressure remains above 147 kPa (1.5 kgf/cm², 21 psi) for 5 minutes after the engine is turned off.

If not within the specification, check the fuel pump, pressure regulator and/or injectors.

(t) After checking fuel pressure, disconnect the battery ground strap and carefully remove the SST to prevent gasoline from splashing.

(u) Using new gaskets, reconnect the cold start injector pipe to the delivery pipe and cold start injector.

(v) Connect the wiring connector to the cold start injector.

(w) Start the engine and check for fuel leakage.

COMPONENTS FOR REMOVAL AND INSTALLATION

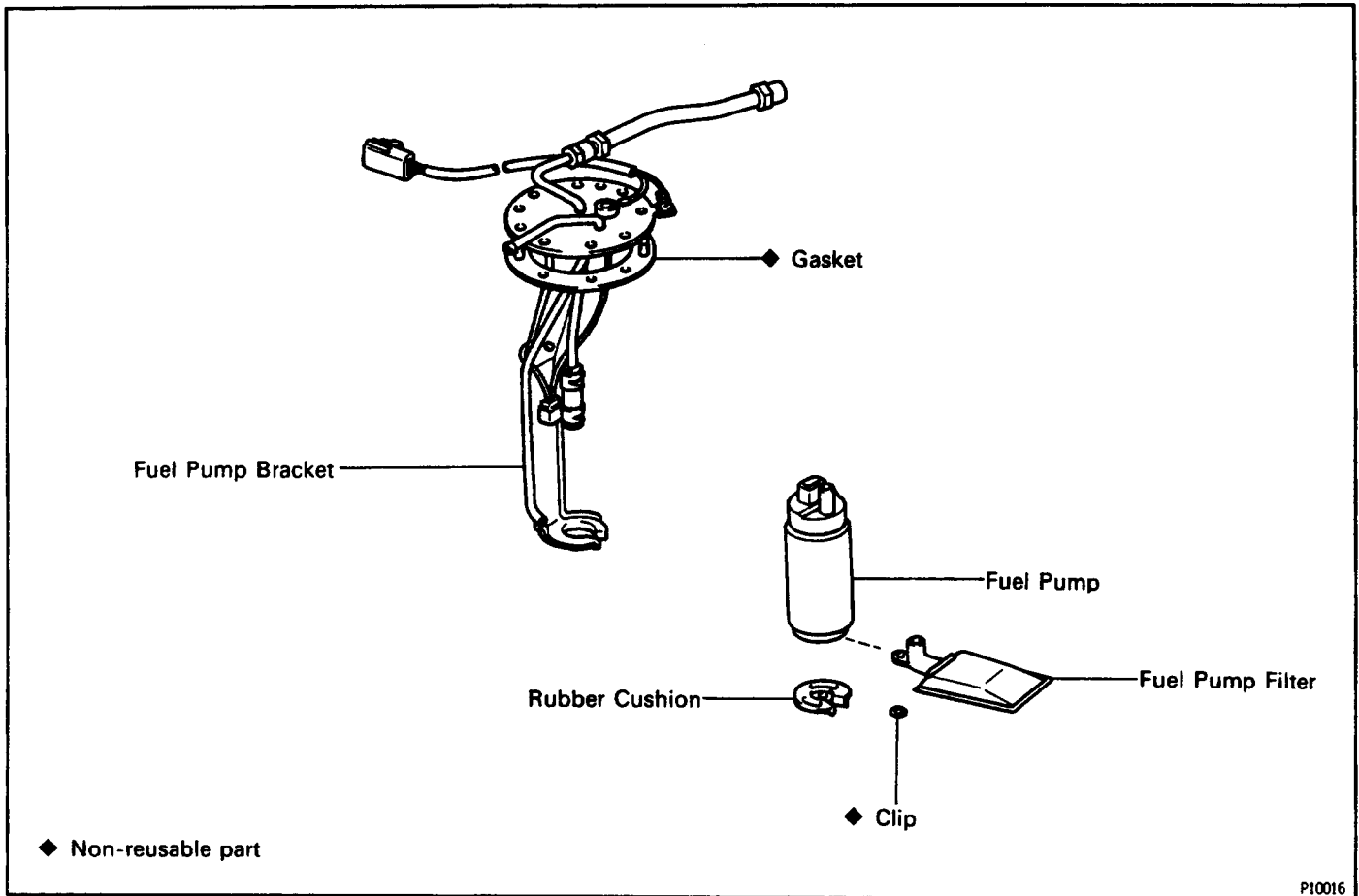

FUEL PUMP REMOVAL

1. DRAIN FUEL FROM FUEL TANK

CAUTION: Do not smoke or work near an open flame when working on the fuel pump.

2. REMOVE FUEL TANK

3. REMOVE FUEL PUMP BRACKET

- (a) Remove the 7 bolts.
- (b) Pull out the fuel pump bracket.

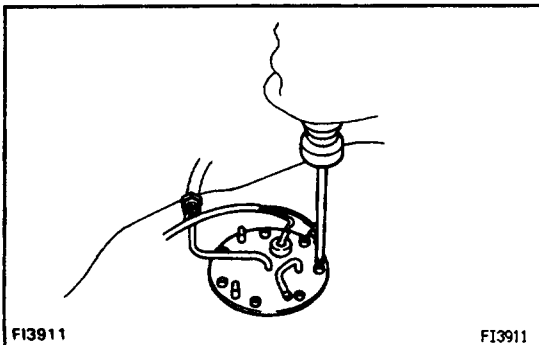

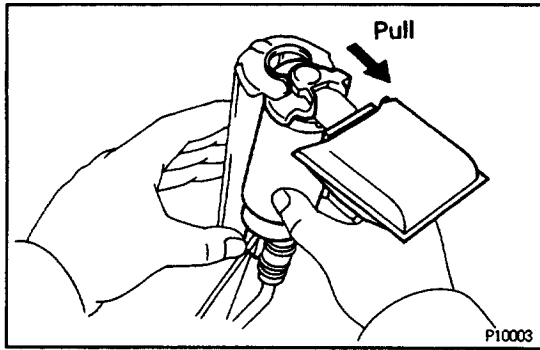

- 4. REMOVE FUEL PUMP FROM FUEL PUMP BRACKET**
- Pull off the lower side of the fuel pump from the pump bracket.
 - Disconnect the fuel pump connector.
 - Disconnect the fuel hose from the fuel pump, and remove the fuel pump.
 - Remove the rubber cushion from the fuel pump.

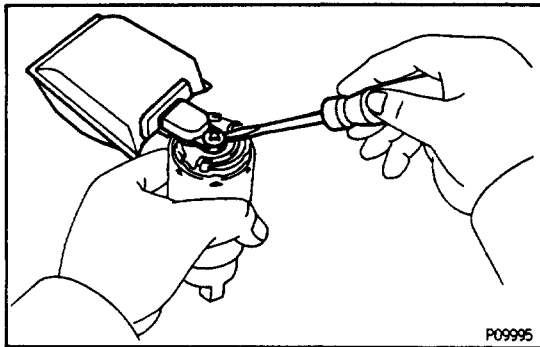

- 5. REMOVE FUEL PUMP FILTER FROM FUEL PUMP**
- Using a small screwdriver, remove the clip.
 - Pull out the pump filter.

FUEL PUMP INSTALLATION

(See Components for Removal and Installation)

1. INSTALL FUEL PUMP FILTER TO FUEL PUMP

Install the pump filter with a new clip.

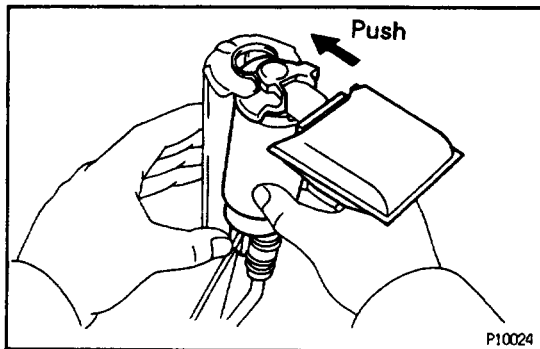

- 2. INSTALL FUEL PUMP TO FUEL PUMP BRACKET**
- Install the rubber cushion to the fuel pump.
 - Connect the fuel hose to the outlet port of the fuel pump.
 - Install the fuel pump connector.
 - Install the fuel pump by pushing the lower side of the fuel pump.

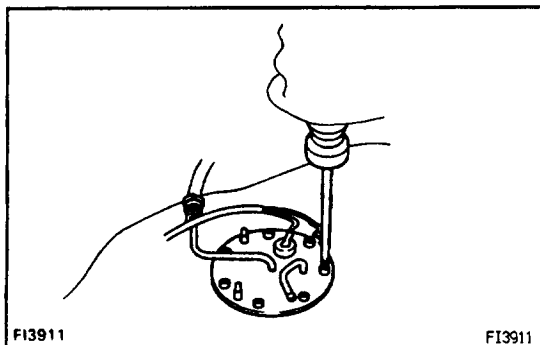

3. INSTALL FUEL PUMP BRACKET

- Place the bracket with a new gasket on the fuel tank.
- Install and tighten the 7 bolts.

Torque: 3.9 N·m (40 kgf·cm, 34 in·lbf)

4. INSTALL FUEL TANK**NOTICE:**

- Tighten the pipe and flare nut type hose to the specified torque.
- Push in the pipe and insert-type hose to the specified position, and install the clip to the specified location.
- If reusing the hose, reinstall the clip at the original location.

5. REFILL WITH FUEL