

HEATED OXYGEN SENSOR HEATED OXYGEN SENSOR INSPECTION

1. INSPECT HEATER RESISTANCE OF HEATED OXYGEN SENSOR

Using an ohmmeter, measure the resistance between the terminals +B and HT.

Resistance:

5-7 Ω at 20°C (68°F)

If the resistance is not as specified, replace the heated oxygen sensor.

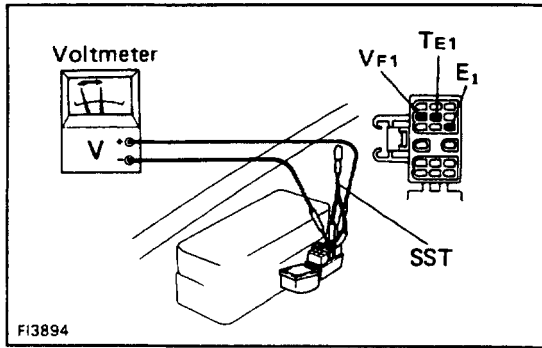

2. INSPECTION OF FEEDBACK VOLTAGE (VF1)

(a) Warm up the engine.

(b) Connect the voltmeter to the DLC1 terminals VF1 and E1.
HINT: Use SST when connecting between terminals TE1 and E1 of the DLC1.

SST 09843-18020

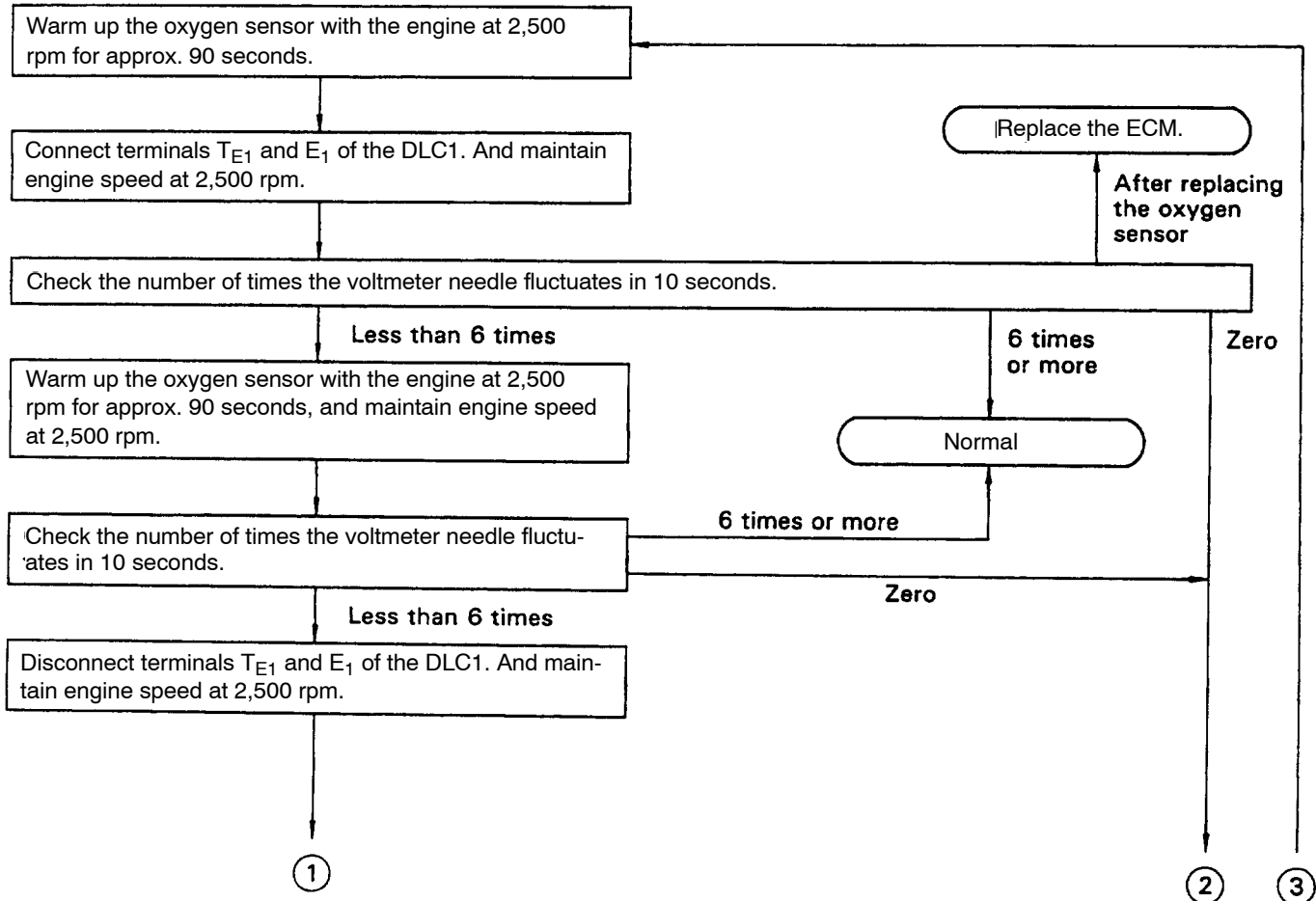

CONTINUED FROM PAGE EG1-216

