

FUEL TANK AND LINE COMPONENTS

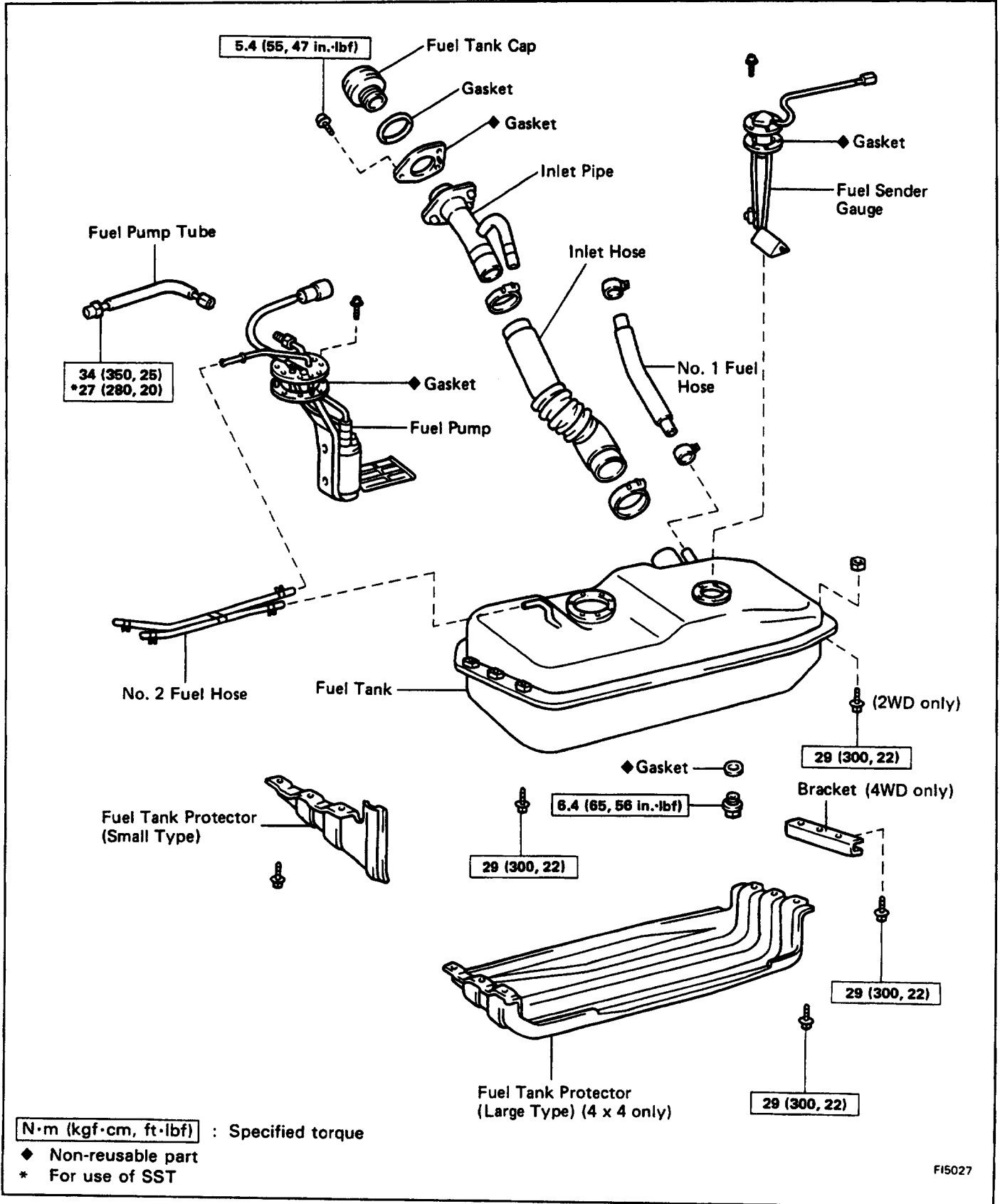

PRECAUTIONS

1. Always use new gaskets when replacing the fuel tank or component part.
2. Apply the proper torque to all parts tightened.

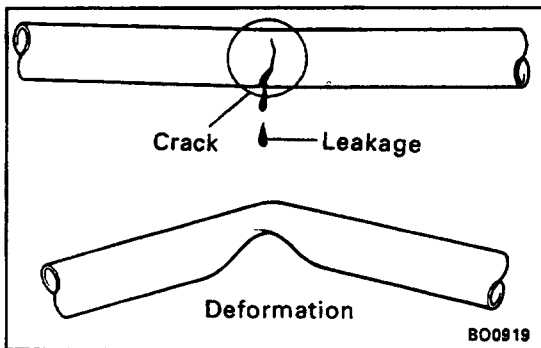

FUEL LINES AND CONNECTIONS INSPECTION

- (a) Inspect the fuel lines for cracks or leakage, and all connections for deformations.
- (b) Inspect the fuel tank vapor vent system hoses and connections for looseness, sharp bends or damage.
- (c) Inspect the fuel tank for deformations, cracks or fuel leakage.
- (d) Inspect the filler neck for damage or fuel leakage.
- (e) Hose and tube connections are as shown in the illustration. If a problem is found, repair or replace the parts as necessary.

