

CYLINDER BLOCK COMPONENTS

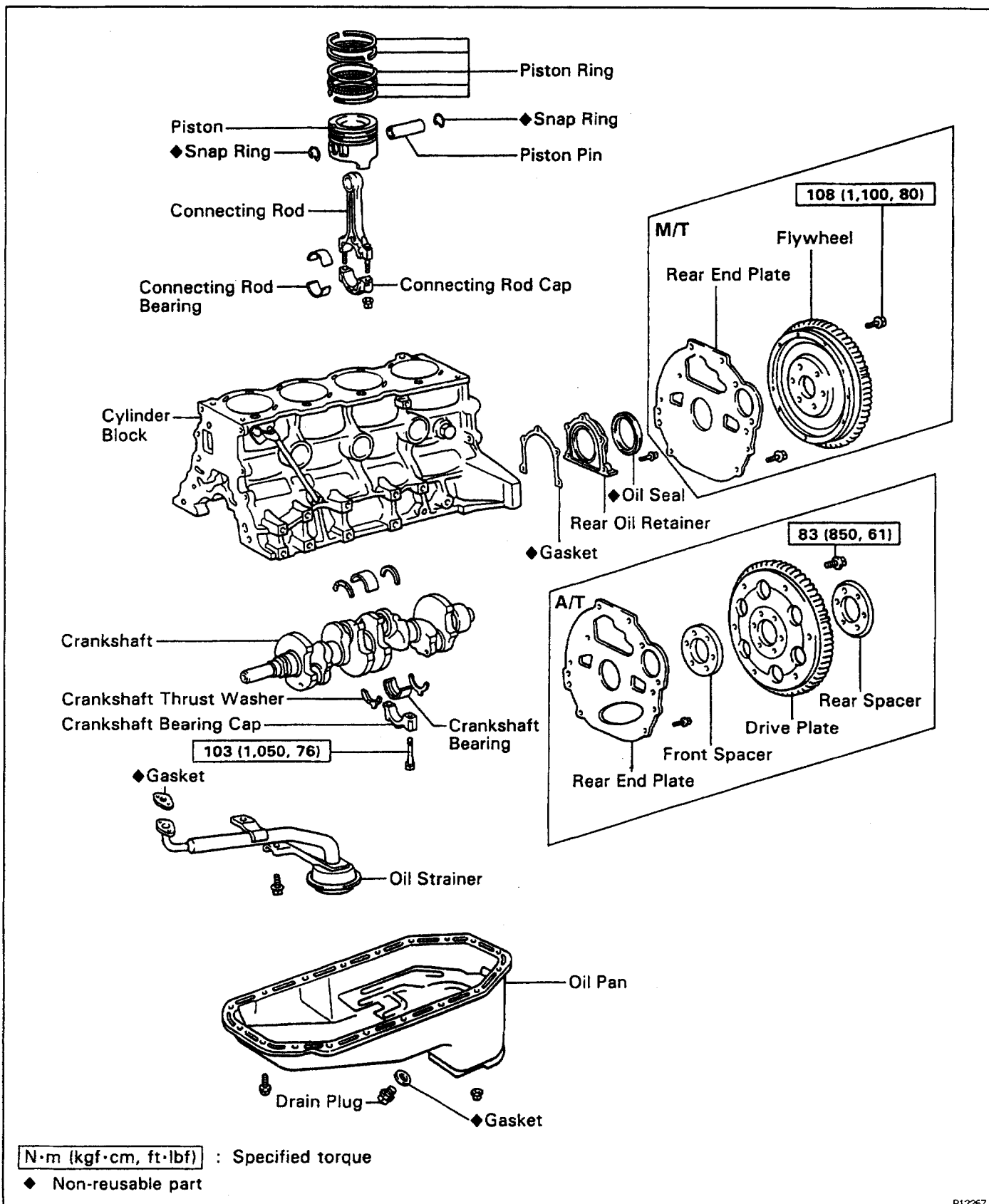

ENGINE REMOVAL

1. REMOVE HOOD
2. REMOVE BATTERY
3. REMOVE ENGINE UNDER COVER
4. DRAIN COOLANT FROM RADIATOR AND CYLINDER BLOCK
(See step 3 on page [EG1-230](#))
5. DRAIN ENGINE OIL
(See step 1 on page [EG1-242](#))
6. REMOVE AIR CLEANER CASE AND INTAKE AIR CONNECTOR
7. REMOVE RADIATOR
(See page [EG1-236](#))
8. REMOVE PS PUMP BELT
 - (a) Stretch the belt tight and loosen the PS pump pulley lock nut.
 - (b) Remove the PS belt.
9. w/ A/C:
REMOVE A/C BELT
10. REMOVE GENERATOR DRIVE BELT, FLUID COUPLING AND FAN PULLEY
(See step 3 on page [EG1-41](#))
11. DISCONNECT FOLLOWING WIRES AND CONNECTORS:
 - (a) Ground strap from LH fender apron
 - (b) Generator connector and wire
 - (c) Igniter connector
 - (d) Generator wires
 - (e) High-tension cord for ignition coil
 - (f) Distributor wire from igniter
 - (g) Ground strap from engine rear side
 - (h) ECM connectors
 - (i) M/T:
Starter relay connector
 - (j) Check connector
 - (k) w/ A/C:
A/C compressor connector
12. DISCONNECT FOLLOWING HOSES:
 - (a) PS air hoses from gas filter and air pipe
 - (b) Brake booster hose
 - (c) w/Cruise control: Cruise control vacuum hose
 - (d) Charcoal canister hose from canister

13. DISCONNECT FOLLOWING CABLE:

- (a) Accelerator cable
- (b) A/T:
Throttle cable
- (c) w/Cruise control:
Cruise control cable

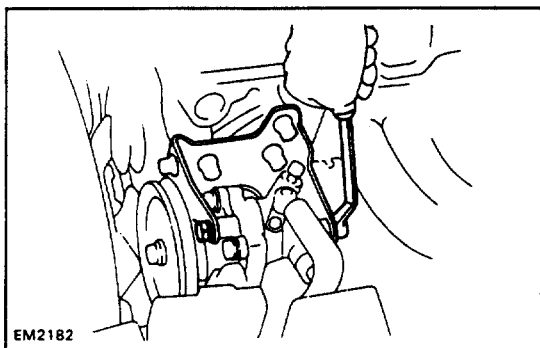

EM2182

14. w/ PS:**REMOVE PS PUMP FROM BRACKET**

- (a) Remove the drive belt.
 - (b) Remove the 4 bolts.
 - (c) Remove the PS pump.
- HINT: Lay the PS pump to one side without disconnecting the hoses.

15. DISCONNECT GROUND STRAP FROM PS PUMP BRACKET**16. w/ A/C:****REMOVE COMPRESSOR FROM BRACKET**

- (a) Loosen the drive belt adjusting bolt and remove the drive belt.
- (b) Remove the compressor on the front side without disconnecting the hoses.

17. DISCONNECT GROUND STRAPS FROM ENGINE REAR SIDE AND RH SIDE**18. M/T:****REMOVE SHIFT LEVER(S) FROM INSIDE OF VEHICLE****19. REMOVE REAR PROPELLER SHAFT**

(See PR section)

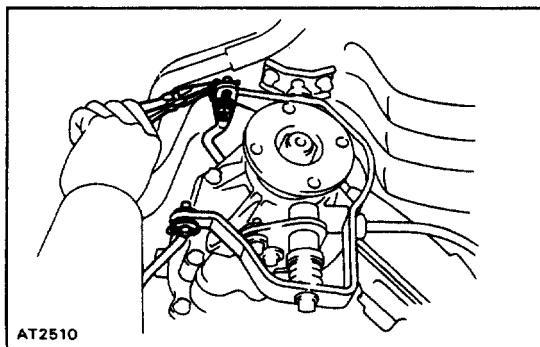
20. 2WD A/T:**DISCONNECT MANUAL SHIFT LINKAGE FROM PNP SWITCH PNP SWITCH**

AT2510

21. 4WD A/T:**DISCONNECT TRANSFER SHIFT LINKAGE**

- (a) Disconnect the No.1 and No.2 transfer shift linkages from the cross shaft.

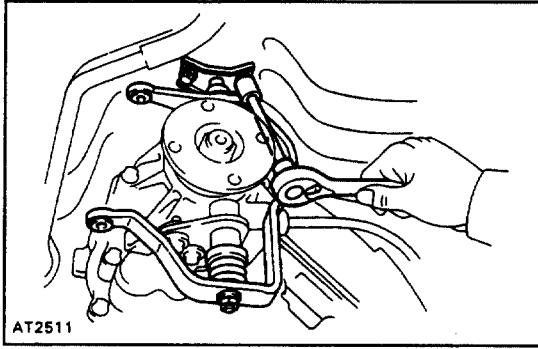

- (b) Remove the cross shaft from the body.

22. DISCONNECT SPEEDOMETER CABLE

NOTICE: Do not lose the felt dust protector and washers.

23. 4WD:

REMOVE TRANSFER UNDER COVER

24. 4WD:

REMOVE STABILIZER BAR

25. 4WD:

REMOVE FRONT PROPELLER SHAFT

(See PR section)

26. REMOVE NO.1 FRAME CROSSMEMBER

27. REMOVE FRONT EXHAUST PIPE

- (a) Disconnect the oxygen sensor connector.
 (b) Disconnect the exhaust pipe from the exhaust manifold.
 (c) Remove the exhaust pipe clamp from the clutch housing.
 (d) Remove the exhaust pipe from the catalytic converter.

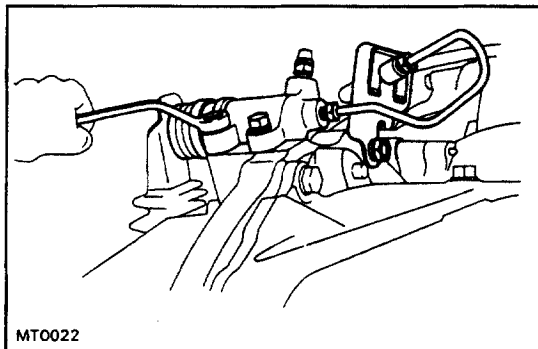
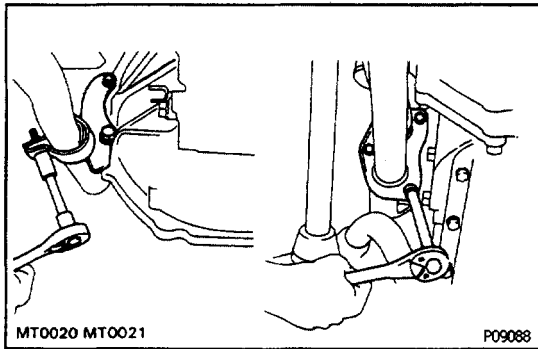

28. M/T:

REMOVE CLUTCH RELEASE CYLINDER WITH BRACKET FROM TRANSMISSION

29. 4WD:

REMOVE NO.1 FRONT FLOOR HEAT INSULATOR AND BRAKE TUBE HEAT INSULATOR

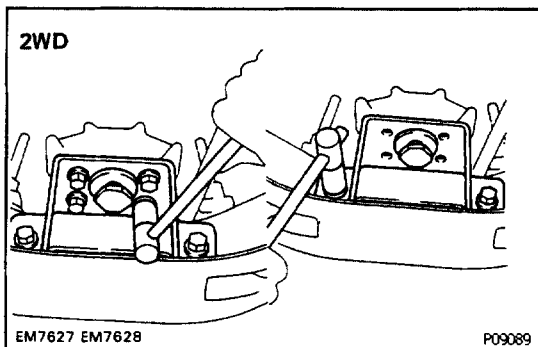

30. 2WD:

REMOVE ENGINE REAR MOUNTING AND BRACKET

- (a) Remove the 4 bolts from the engine rear mounting.
 (b) Raise the transmission slightly by raising the engine with a jack.
 (c) Remove the 4 bolts from the support member.

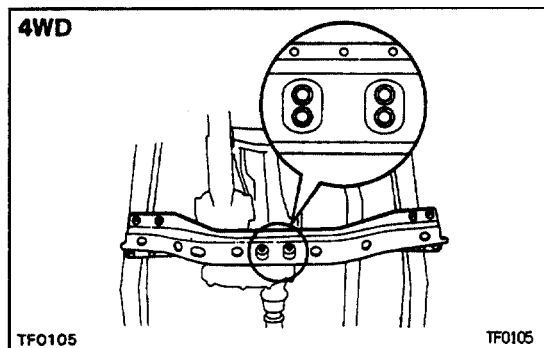

- 31. 4WD:**
REMOVE NO.2 FRAME CROSSMEMBER FROM SIDE FRAME
- (a) Remove the 4 bolts from the engine rear mounting.
 - (b) Raise the transmission slightly with a jack.
 - (c) Remove the 4 bolts from the side frame and remove the No.2 frame crossmember.

- 32. REMOVE ENGINE WITH TRANSMISSION FOR VEHICLE**
- (a) Attach the engine hoist chain to the lift brackets of the engine.
 - (b) Remove the mounting nuts and bolts.
 - (c) Lift engine out of the vehicle slowly and carefully.
HINT: Make sure the engine is clear of all wiring and hoses.

33. REMOVE TRANSMISSION FROM ENGINE

- (a) A/T:
Remove the A/T oil cooler pipes.
- (b) Remove the starter.
- (c) Remove the 2 stiffener plates and exhaust pipe bracket from the engine.
- (d) Remove the transmission from the engine.

- 34. M/T:**
REMOVE CLUTCH COVER AND DISC

CYLINDER BLOCK DISASSEMBLY

(See Components)

1. REMOVE FLYWHEEL OR DRIVE PLATE
2. REMOVE REAR END PLATE
3. INSTALL ENGINE STAND FOR DISASSEMBLY
4. REMOVE CYLINDER HEAD
(See page [EG1-19](#))
5. REMOVE TIMING CHAIN
(See page [EG1-41](#))
6. REMOVE GENERATOR
(See CH section)
7. REMOVE LH ENGINE MOUNTING BRACKET AND GENERATOR BRACKET
8. REMOVE CHAIN DAMPERS
9. REMOVE CHAIN TENSIONER
10. REMOVE OIL FILTER
(See step 2 on page [EG1-242](#))
11. REMOVE RH ENGINE MOUNTING BRACKET, CHAMBER STAY AND GROUND STRAP
12. A/T:
REMOVE FLEXIBLE HOSE CLAMP
13. REMOVE OIL PRESSURE SENDER GAUGE OR SWITCH
14. REMOVE KNOCK CONTROL SENSOR
15. REMOVE FUEL FILTER AND BRACKET

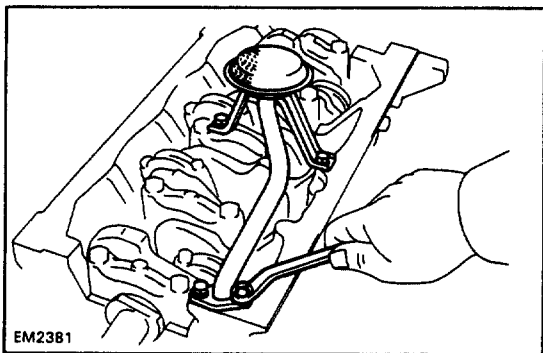

16. REMOVE OIL STRAINER
Remove the 4 bolts, strainer and gasket.

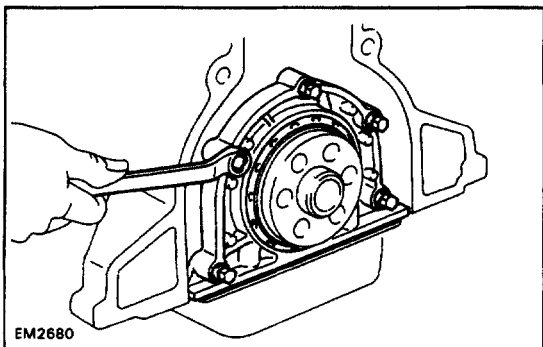

17. REMOVE REAR OIL SEAL RETAINER
Remove the 5 bolts, rear oil seal retainer and gasket.

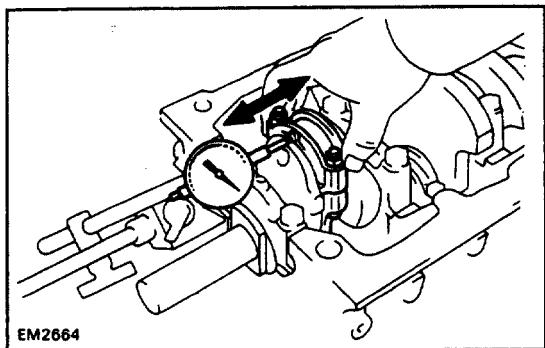
**18. MEASURE CONNECTING ROD THRUST CLEARANCE**

Using a dial gauge, measure the thrust clearance.

Standard clearance:

0.16–0.26 mm (0.063–0.0102 in.)

Maximum clearance:

0.3 mm(0.012 in.)

If clearance is greater than maximum, replace the connecting rod and/or crankshaft.

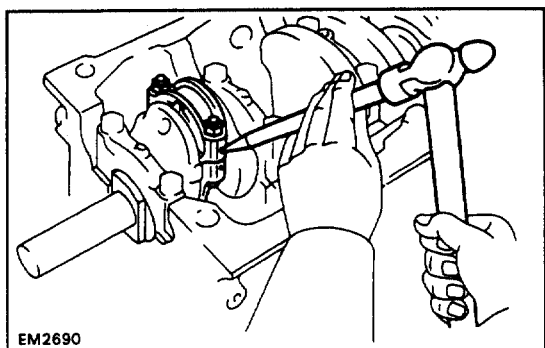
**19. MEASURE CONNECTING ROD OIL CLEARANCE**

(a) Using a punch or numbering stamp, mark connecting rods and caps to ensure correct reassembly.

(b) Remove the rod cap nuts.

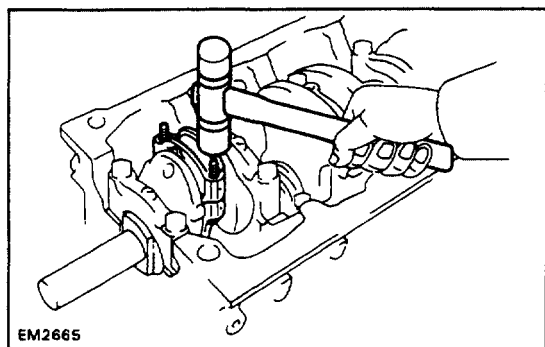

(c) Using a plastic-faced hammer, tap the rod bolts lightly and lift off the rod cap.

HINT: Keep the bearing inserted in the cap.

(d) Clean the bearing and crankshaft pins.

(e) Inspect each bearing for pitting and radial scratches. If bearing are damaged, replace the bearings.

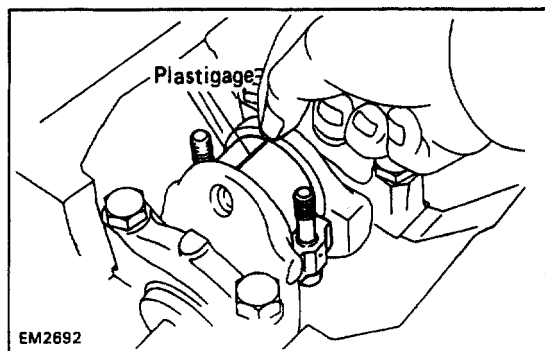

(f) Lay a strip of Plastigage across the crankshaft pin.

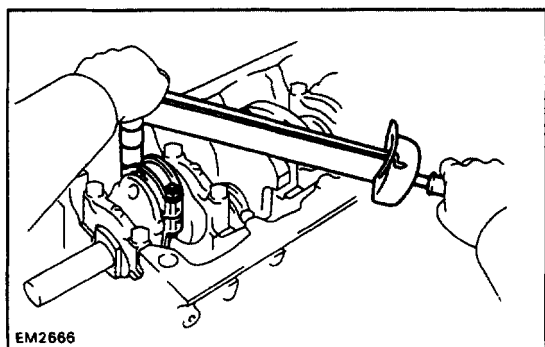

(g) Align the rod and cap marks and fit on the cap. Install and torque the cap nuts.

Torque: 69 N·m (700 kgf·cm, 51 ft.lbf)

HINT:

- Do not turn the crankshaft.
- Apply a light coat of engine oil on the nut threads and under the nut before installation.

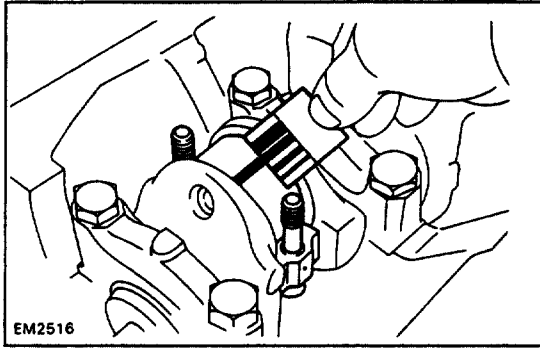

- (h) Remove the rod cap.
- (i) Measure the Plastigage at its widest point.

Standard clearance:

0.025–0.055 mm (0.0010–0.0022 in.)

Maximum clearance:

0.10 mm (0.0039 in.)

If the clearance is greater than maximum, replace the bearings and/or grind the crank pins.

Undersized bearing:

U/S 0.25

- (j) Clean any Plastigage from bearing and crankshaft pin.

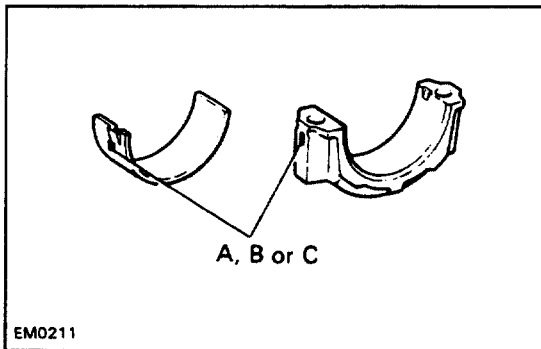

HINT: If replacing a standard size bearing, replace with one having the same letter as marked on the bearing cap. There are 3 sizes of standard bearings supplied, marked A, B or C respectively.

Size	Big End Inner Diameter	Crank Pin Diameter	Bearing Center Wall Thickness
A	56.000–56.006 (2.2047–2.2050)	52.988–53.000 (2.0861–2.0866)	1.484–1.488 (0.0584–0.0586)
B	56.006–56.012 (2.2050–2.2052)		1.488–1.492 (0.0586–0.0587)
C	56.012–56.018 (2.2052–2.2054)		1.492–1.496 (0.0587–0.0589)
U/S 0.25	56.000–56.018 (2.2047–2.2054)	52.701–52.711 (2.0748–2.0752)	1.626–1.636 (0.0640–0.0644)

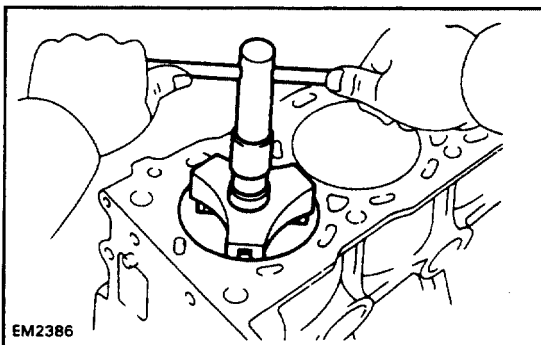

20. PUSH OUT PISTON AND CONNECTING ROD ASSEMBLY

- (a) Remove all the carbon from top of the bore to the top of the cylinder.

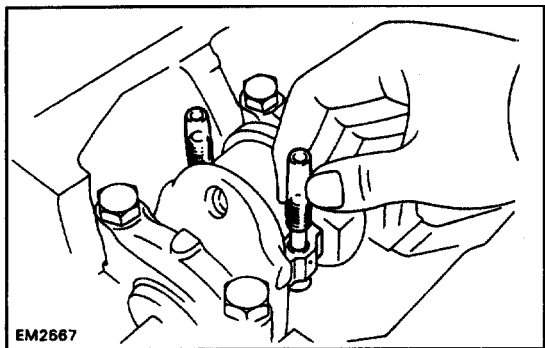

- (b) Cover the rod bolts with a short piece of hose to protect the crank pin from damage.
- (c) Push the piston and connecting rod assembly out through the top of the cylinder block.

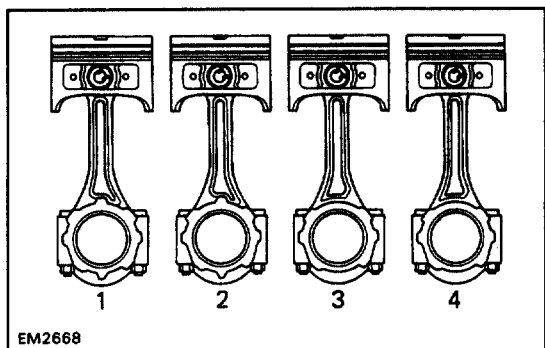

- (d) Arrange the piston and connecting rod caps in order.

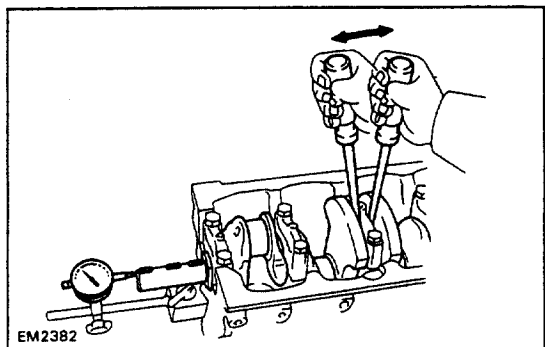

21. MEASURE CRANKSHAFT THRUST CLEARANCE

Using a dial gauge, measure the crankshaft thrust clearance while prying the crankshaft back and forth with a screwdriver.

Standard clearance:

0.02-0.22 mm (0.0008-0.0087 in.)

Maximum clearance:

0.3 mm (0.012 in.)

If the clearance is greater than maximum, replace the thrust washers as a set and/or crankshaft.

Thrust washer thickness:

Standard

2.690-2.740 mm (0.1059-0.1079 in.)

O/S 1.25

2.753-2.803 mm (0.1084-0.1104 in.)

O/S 2.50

2.815-2.865 mm (0.1108-0.1128 in.)

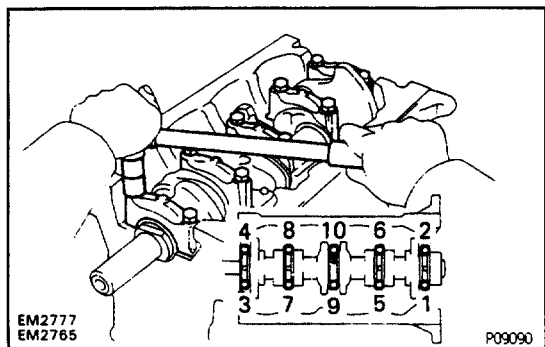

22. MEASURE CRANKSHAFT OIL CLEARANCE

- (a) Gradually loosen and remove the bearing cap bolts in 3 passes and in numerical order shown.

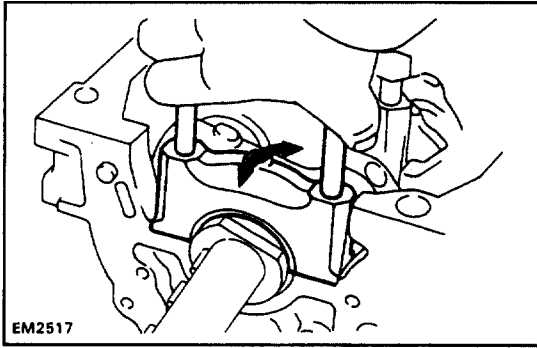

- (b) Using the removed bearing cap bolts, pry the bearing cap fore and aft, and remove it with the lower bearing and (No.3 journal only) thrust washers.

HINT:

- Keep the lower bearing inserted in the cap.
- Arrange the caps and lower thrust washers in correct order.

- (c) Lift off the crankshaft.

HINT: Keep the upper bearings and upper thrust washers (for the No.3 journal only) inserted in the cylinder block.

- (d) Clean the journals and bearings.

- (e) Check the journals and bearings for pitting and scratches. If the journal or bearing is damaged, grind or replace the crankshaft and replace the bearing.

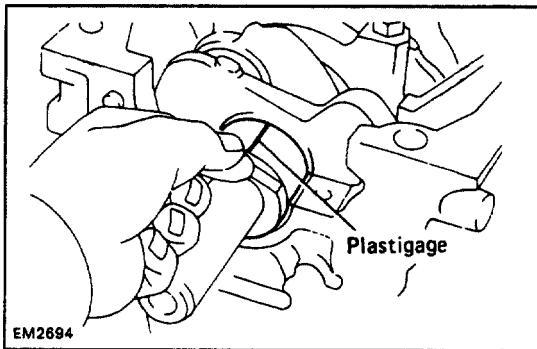

- (f) Install the upper main bearings on the cylinder block and crankshaft.

- (g) Lay a strip of Plastigage across the main journals.

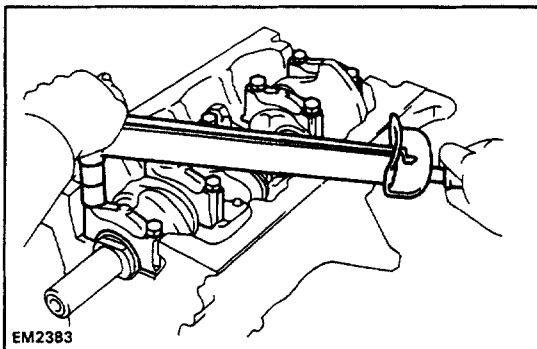

- (h) Install the main bearing caps with the front mark facing forward. Install and torque the cap bolts.

Torque: 103 N·m (1,050 kgf·cm, 76 ft·lbf)

HINT:

- Do not turn the crankshaft.
- Apply a light coat of engine oil on the bolt threads before installation.

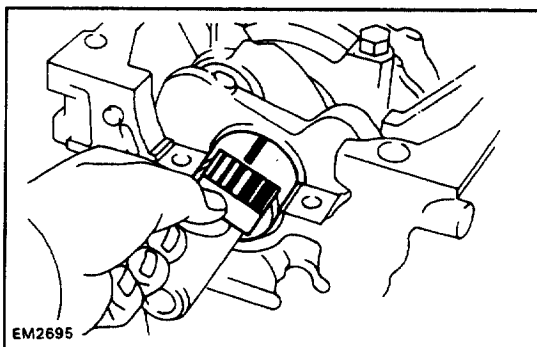

- (i) Remove the main bearing caps.

- (j) Measure the Plastigage at its widest point.

Standard clearance:

0.025–0.055 mm (0.0010–0.0022 in.)

Maximum clearance:

0.08 mm (0.0031 in.)

If the clearance is greater than maximum, replace the bearings and/or grind the main journals.

Undersized bearing:**U/S 0.25**

- (k) Clean out the pieces of Plastigage from the bearings and journals.

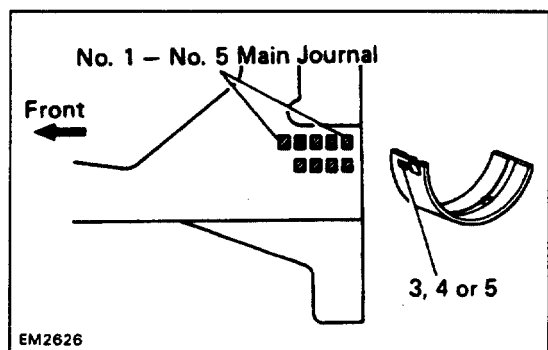

HINT: If using a standard bearing, replace with one having the same number as marked on the cylinder block. There are 3 sizes of standard bearings, marked 3, 4, 5 accordingly.

mm (in.)

Size	Cylinder Block Main Journal Bore	Main Journal Diameter	Bearing Center Wall Thickness
3	64.004-64.010 (2.5198-2.5201)	59.984-60.000 (2.3616-2.3622)	1.988-1.992 (0.0783-0.0784)
4	64.010-64.016 (2.5201-2.5203)		1.992-1.996 (0.0784-0.0786)
5	64.016-64.022 (2.5203-2.5205)		1.996-2.000 (0.0786-0.0787)
U/S 0.25	64.004-64.022 (2.5198-2.5205)	59.701-59.711 (2.3504-2.3508)	2.126-2.136 (0.0837-0.0841)

23. REMOVE CRANKSHAFT

- (a) Lift out the crankshaft.
- (b) Remove the upper main bearings from the cylinder block.
- (c) Arrange the caps and bearings in order.

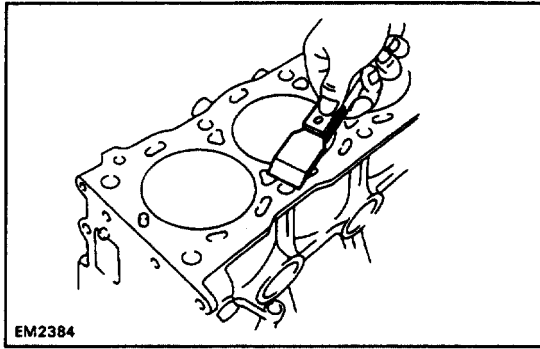

CYLINDER BLOCK INSPECTION

1. REMOVE GASKET MATERIAL

Using a gasket scraper, remove all gasket material from cylinder block surfaces.

2. CLEAN CYLINDER BLOCK

Using a soft brush and solvent, clean the block.

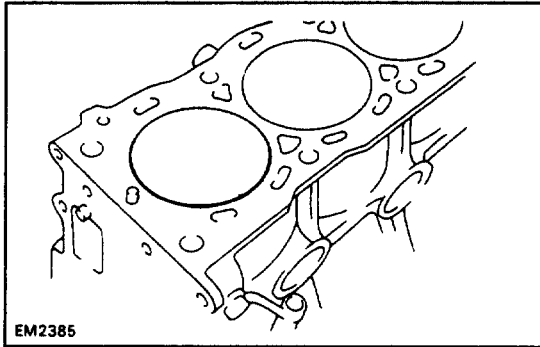

3. INSPECT CYLINDERS

Visually inspect cylinders for vertical scratches.

If deep scratches are present, rebore all 4 cylinders.

(See page [EG1-68](#))

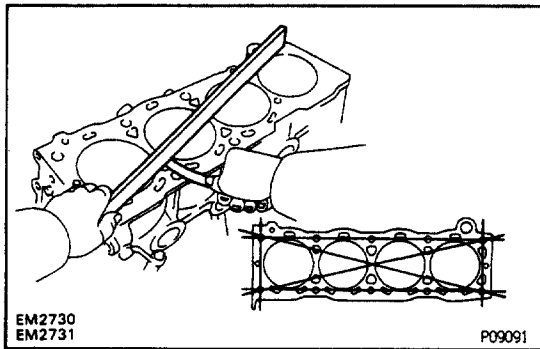

4. INSPECT CYLINDER BLOCK WARPAGE

Warpage limit:

0.05 mm (0.0020 in.)

If warpage is greater than specified value, replace the cylinder block.

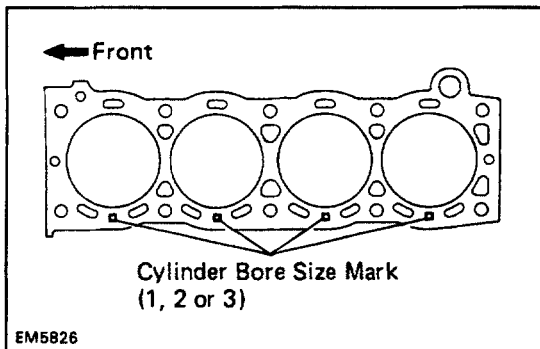

5. MEASURE CYLINDER BORE

HINT: There are 3 sizes of the standard cylinder bore diameter, marked "1", "2", and "3", accordingly. The mark is stamped on the cylinder block.

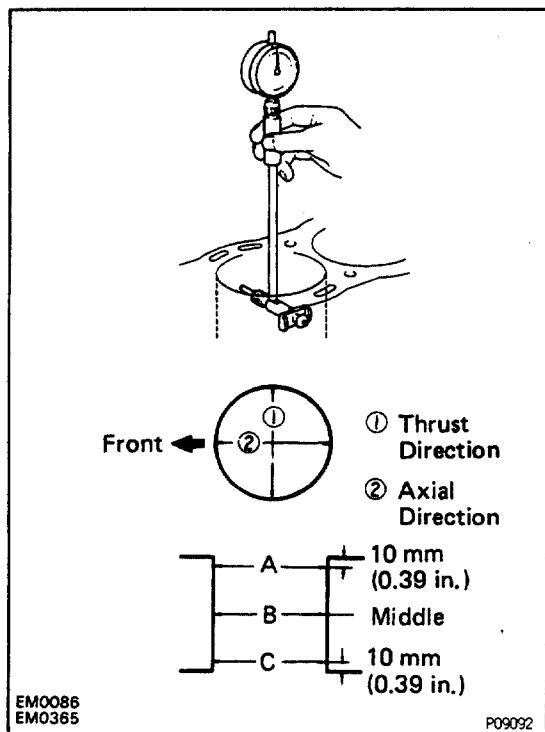

Using a cylinder gauge, measure the cylinder bore diameter at positions A, B and C in the thrust and axial directions.

Standard diameter:

STD

Mark "1"

92.00–92.01 mm (3.6220–3.6224 in.)

Mark "2"

92.01–92.02 mm (3.6224–3.6228 in.)

Mark "3"

92.02–92.03 mm (3.6228–3.6232 in.)

O/S 0.50

92.50–92.53 mm (3.6417–3.6429 in.)

O/S 1.00

93.00–93.03 mm (3.6614–3.6626 in.)

Maximum diameter:

STD

92.23 mm (3.6311 in.)

O/S 0.50

92.73 mm (3.6508 in.)

O/S 1.00

93.23 mm (3.6705 in.)

If the diameter is greater than maximum, rebore all 4 cylinders, or replace the cylinder block.

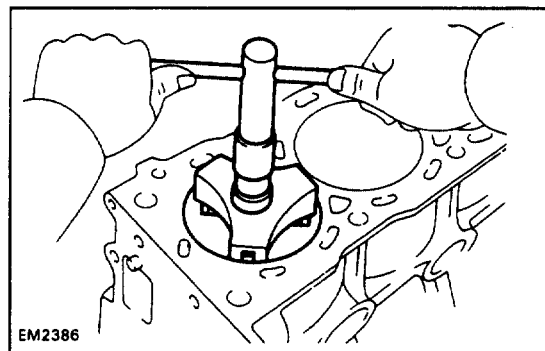

6. REMOVE CYLINDER RIDGE

If wear is less than 0.2 mm (0.008 in.), use a ridge reamer to machine the top of the cylinder.

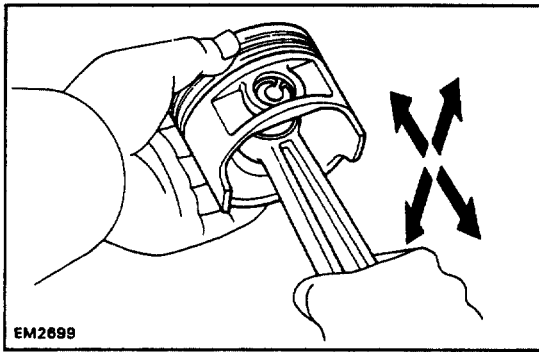

DISASSEMBLY OF PISTON AND CONNECTING ROD ASSEMBLY

1. CHECK FIT BETWEEN PISTON AND PIN

Try to move the piston back and forth on the piston pin. If any movement is felt, replace the piston and pin.

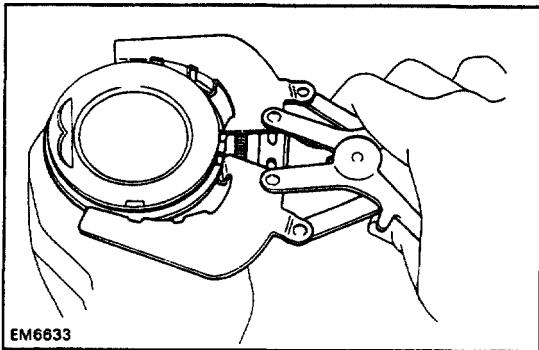

2. REMOVE PISTON RINGS

(a) Using a piston ring expander, remove the compression rings.

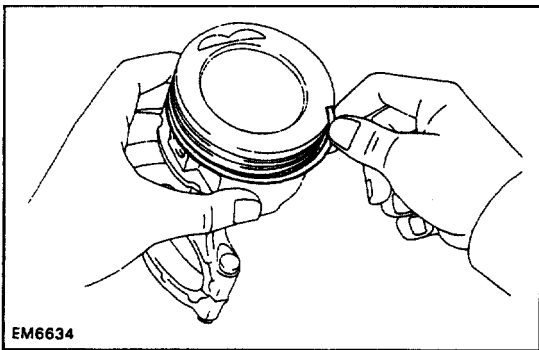

(b) Remove the 2 side rails and oil ring expander by hand.
HINT: Keep the rings for each cylinder separated.

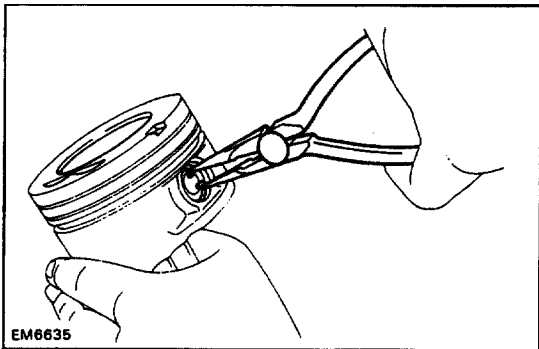

3. DISCONNECT CONNECTING ROD FROM PISTON

(a) Using needle-nose pliers, remove the snap rings from the piston.

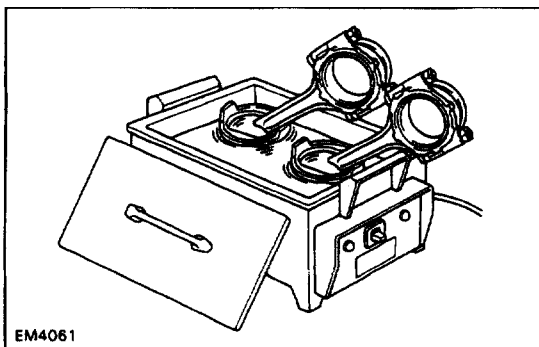

(b) Heat the piston in hot water approx. 60°C(140°F).

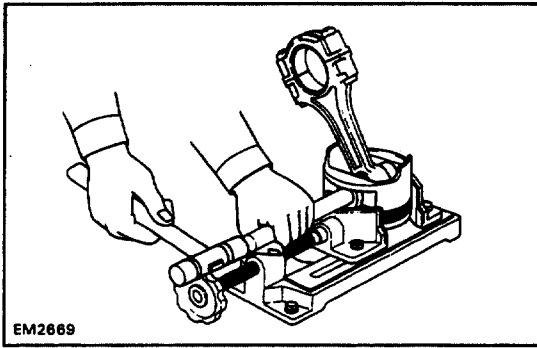

- (c) Using a plastic-faced hammer and brass bar, lightly tap out the piston pin from the piston.

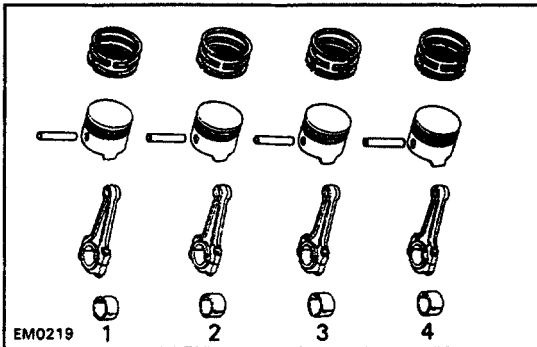

HINT:

- The piston and pin are a matched set.
- Keep the piston, pin, rings and connecting rod together for each cylinder.

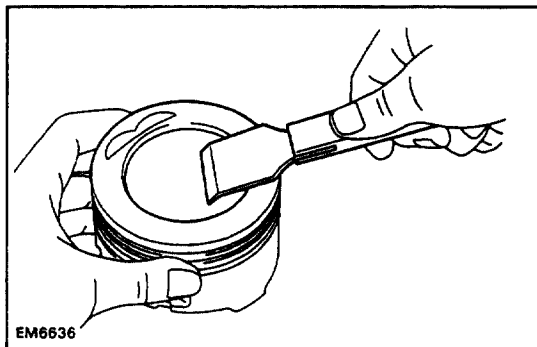

INSPECTION OF PISTON AND CONNECTING ROD

1. CLEAN PISTON

- (a) Using a gasket scraper, remove the carbon from the piston top.

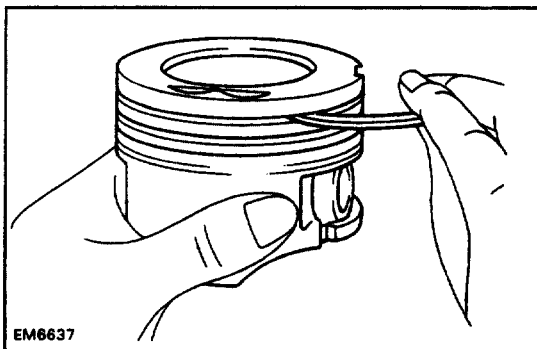

- (b) Using a groove cleaning tool or broken ring, clean the ring grooves.

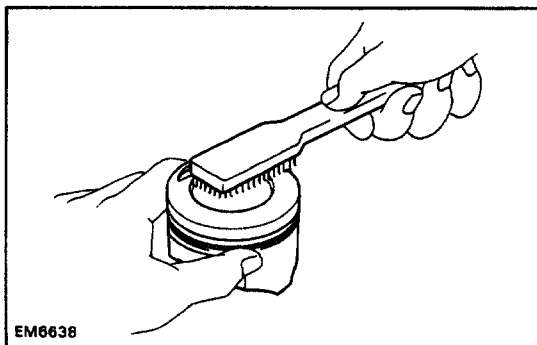

- (c) Using solvent and a brush, thoroughly clean the piston.
NOTICE: Do not use a wire brush.

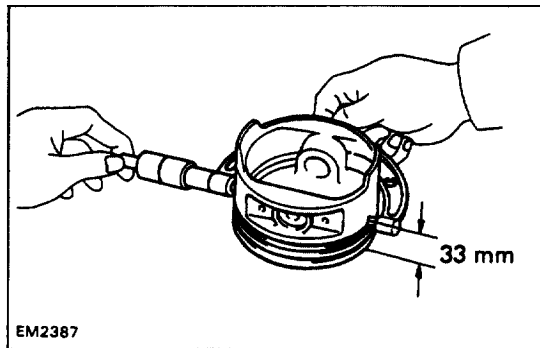
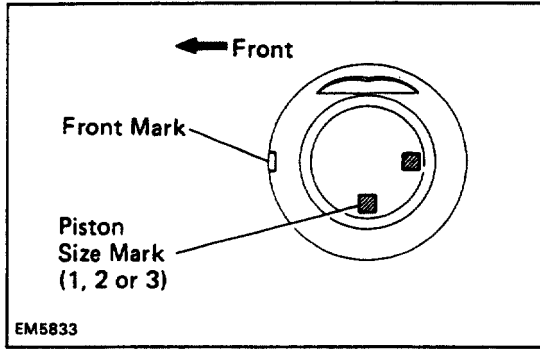

2. INSPECT PISTON DIAMETER AND OIL CLEARANCE

HINT: There are 3 sizes of the standard piston diameter, marked "1", "2", and "3", accordingly. The mark is stamped on the top of the piston.

- (a) Using a micrometer and with the piston upside down, measure the piston diameter at right angles to the piston pin hole center line, at the indicated distance from the piston head.

Distance: 33 mm (1.30 in.)

Piston diameter:

STD

Mark "1"

91.975–91.985 mm (3.6211–3.6214 in.)

Mark "2"

91.985–91.995 mm (3.6214–3.6218 in.)

Mark "3"

91.995–92.005 mm (3.6218–3.6222 in.)

O/S 0.50

92.475–92.505 mm (3.6407–3.6419 in.)

O/S 1.00

92.975–93.005 mm (3.6604–3.6616 in.)

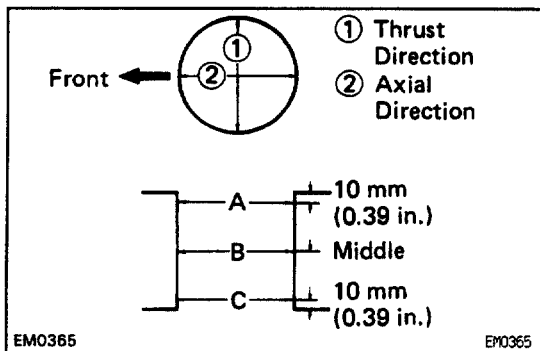

- (b) Measure the cylinder bore diameter in thrust directions (See page [EG1-58](#)) and subtract the piston diameter measurement from the cylinder bore diameter measurement.

Piston clearance:

0.015–0.035 mm (0.0006–0.0014 in.)

If not within specification, replace the pistons. If necessary, rebore or replace the cylinder block.

HINT: When installing a standard piston, install one with the same mark as the standard bore diameter mark on the cylinder block.

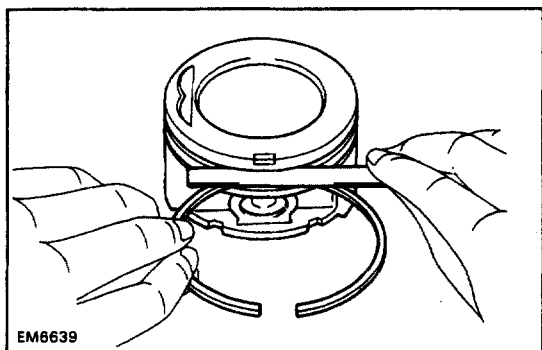

3. MEASURE CLEARANCE BETWEEN PISTON GROOVE AND PISTON RING

Using a thickness gauge, measure the clearance between the piston ring and the ring land.

Standard ring groove clearance:

0.03–0.07 mm (0.0012–0.0028 in.)

Maximum ring groove clearance:

0.2 mm (0.008 in.)

If the clearance is greater than maximum, replace the piston ring and/or piston.

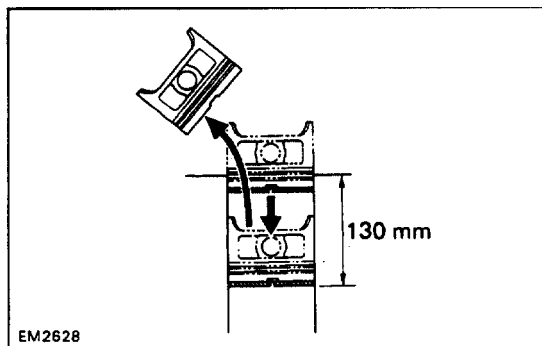

4. MEASURE RING END GAP

- (a) Insert the piston ring into the cylinder.
- (b) Using a piston, push the ring a little beyond the bottom of the ring travel.
(130 mm (5.12 in.) from top surface of cylinder block)

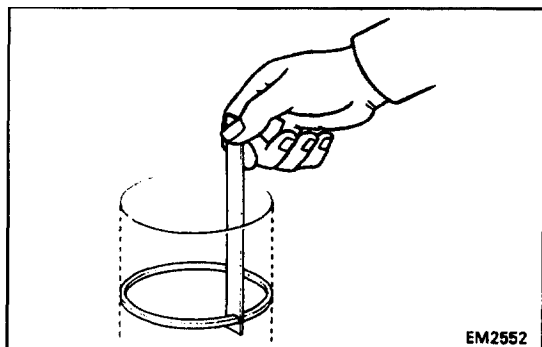

- (c) Using a thickness gauge, measure the end gap.

Standard ring end gap:

No.1

.25–0.47 mm (0.0098–0.0185 in.)

No.2

.60–0.82 mm (0.0236–0.0323 in.)

Oil

.20–0.57 mm (0.0079–0.0224 in.)

Maximum ring end gap:

No.1

1.07 mm (0.0421 in.)

No.2

1.42 mm (0.0559 in.)

Oil

1.17 mm (0.0461 in.)

If the gap is greater than maximum, replace the ring.

Do not file the ring end.

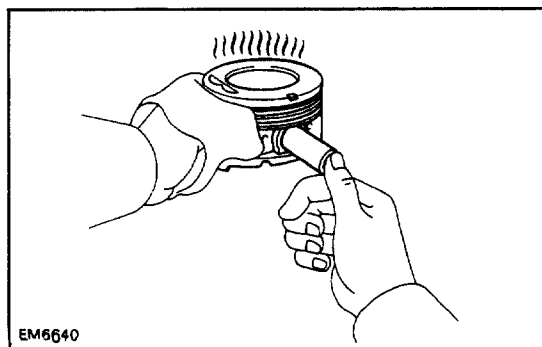

5. INSPECT PISTON PIN FIT

At 80°C (176°F), you should be able to push the pin into the piston with your thumb.

If the pin can be installed at a lower temperature, replace it and the piston.

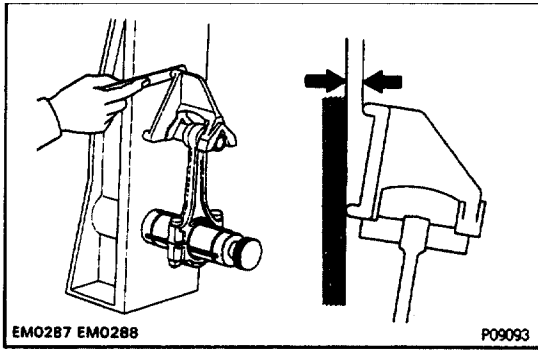

6. INSPECT CONNECTING RODS

- (a) Using a rod aligner, check the connecting rod alignment. If the rod is out-of-alignment or twisted, replace the connecting rod.

- Check that the rod is out-of-alignment.

Maximum out-of-alignment:

0.05 mm (0.0020 in.) per 100 mm (3.94 in.)

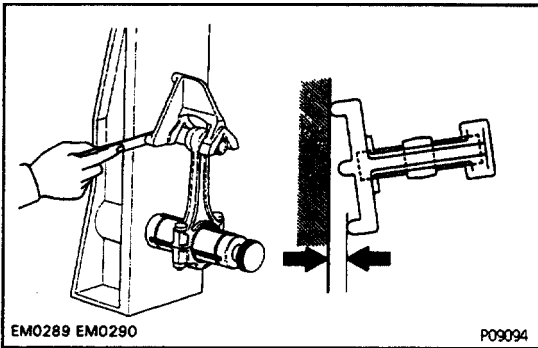

- Check that the rod is not twisted.

Maximum twist:

0.15 mm (0.0059 in.) per 100 mm (3.94 in.)

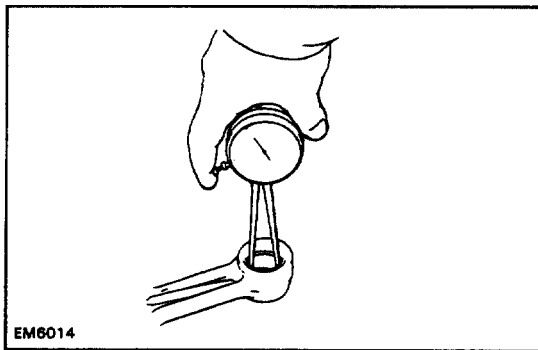

- (b) Measure the oil clearance between the rod bushing and piston pin.

- Using an inside dial indicator, measure the inside diameter of the rod bushing.

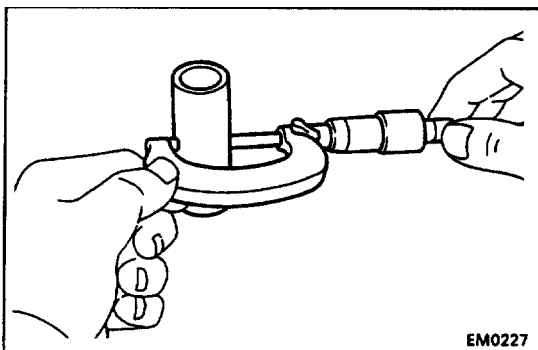

- Using a micrometer, measure the diameter of the piston pin.

- Check that the difference between the measurements is less than the oil clearance limit.

Standard oil clearance:

0.005–0.011 mm (0.0002–0.0004 in.)

Maximum oil clearance:

0.015 mm (0.0006 in.)

If the clearance is greater than maximum, replace the rod bushing.

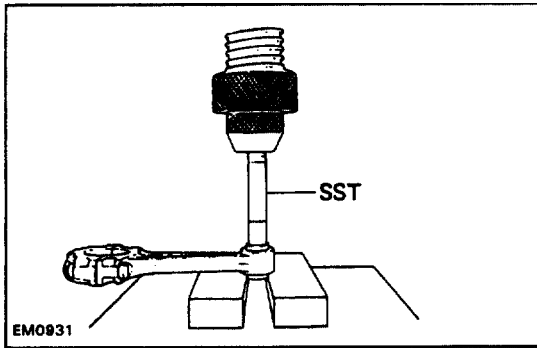

ROD BUSHING REPLACEMENT

1. REMOVE ROD BUSHING

Using SST, remove the rod bushing from the connecting rod.
SST 09222-30010

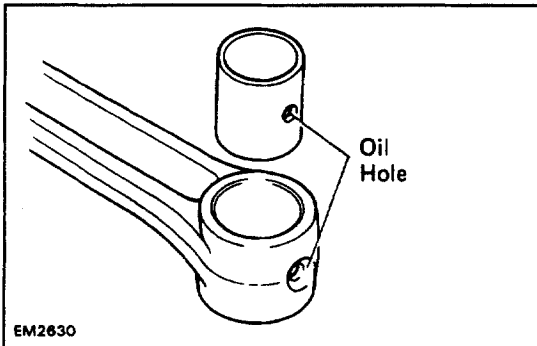

2. INSTALL NEW ROD BUSHING

Using SST, install the rod bushing to the connecting rod.
SST 09222-30010

HINT: Align the bushing oil hole with the connecting rod oil hole.

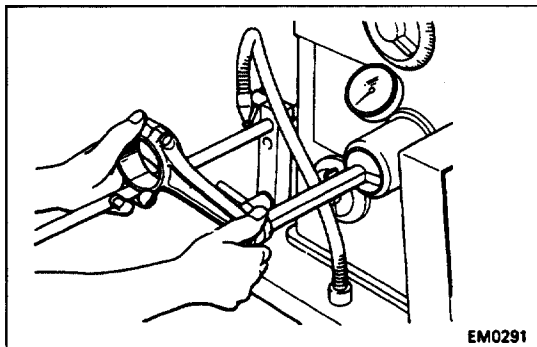

3. HONE NEW BUSHING AND CHECK PIN FIT IN CONNECTING ROD

- (a)hone the new bushing and check that the oil clearance is within standard specification.

Standard oil clearance:

0.005-0.011 mm (0.0002-0.0004 in.)

- (b) Check the pin fit at the normal room temperature. Coat the pin with engine oil and push the pin into the rod with thumb pressure.

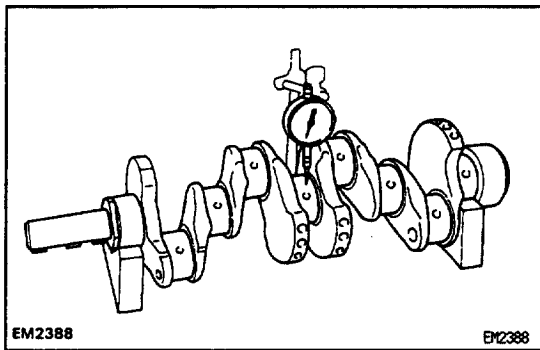

CRANKSHAFT INSPECTION AND REPAIR

1. MEASURE CRANKSHAFT FOR RUNOUT

- (a) Place the crankshaft on V-blocks.
- (b) Using a dial gauge, measure the runout at the center journal.

Maximum circle runout:

0.1 mm (0.004 in.)

If the runout is greater than maximum, replace the crankshaft.

HINT: Use a long spindle on the dial gauge.

2. INSPECT MAIN JOURNALS AND CRANK PINS

- (a) Using a micrometer, measure the diameter of the main journal and crank pin.

Main journal diameter:

59.984–60.000 mm (2.3616–2.3622 in.)

Crank pin diameter:

52.988–53.000 mm (2.0861–2.0866 in.)

If journals are worn, regrind or replace the crankshaft.

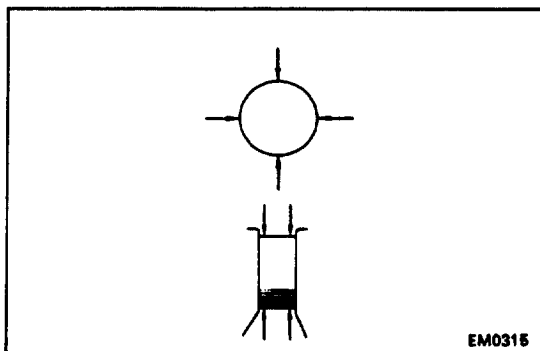
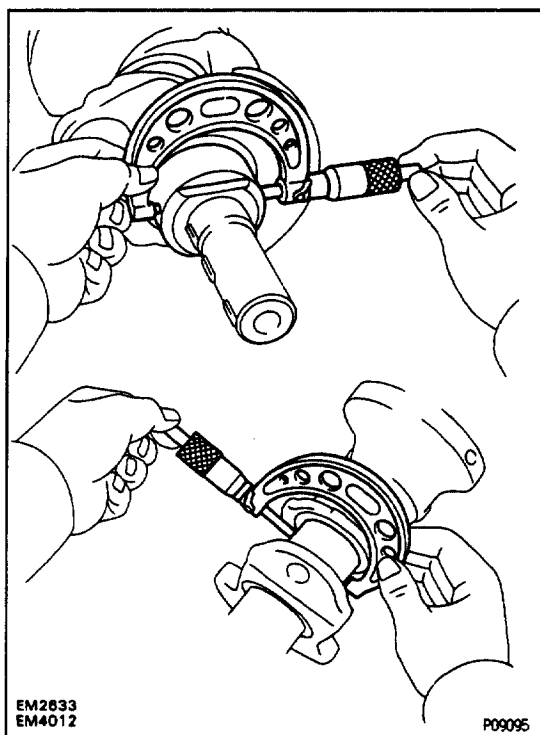

- (b) Measure the journals for out-of-round and taper as shown.

Maximum taper:

0.01 mm (0.0004 in.)

Maximum out-of-round:

0.01 mm (0.0004 in.)

If taper and out-of-round are greater than maximum, regrind and/or replace the crankshaft.

3. GRIND CRANK PIN AND/OR MAIN JOURNAL, IF NECESSARY

- (a) Grind the crank pins and/or main journals to the undersized finished diameter.

Bearing size (U/S 0.25)

Main journal finished diameter:

59.701–59.711 mm (2.3504–2.3508 in.)

Crank pin finished diameter:

52.701–52.711 mm (2.0748–2.0752 in.)

- (b) Install a new pin and/or main undersized bearings.

CRANKSHAFT OIL SEALS REPLACEMENT

HINT: There are 2 methods (A and B) to replace the oil seal which are as follows:

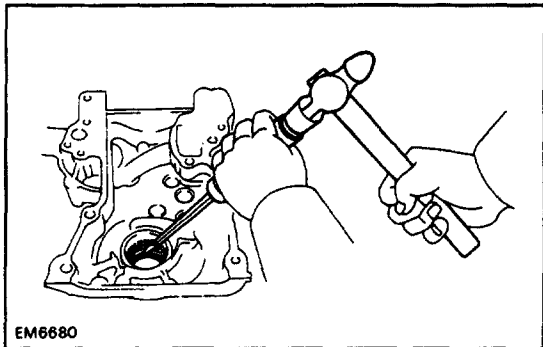

1. REPLACE CRANKSHAFT FRONT OIL SEAL

A. If timing chain cover is removed from cylinder block:

- (a) Using a screwdriver and hammer, tap out the oil seal.

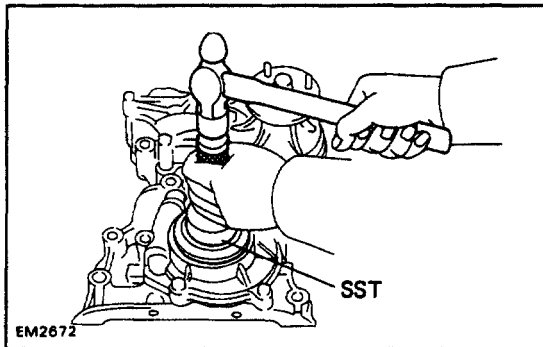

- (b) Using SST and a hammer, tap in the oil seal until its surface is flush with the timing chain cover edge.

SST 09223-50010

- (c) Apply MP grease to the oil seal lip.

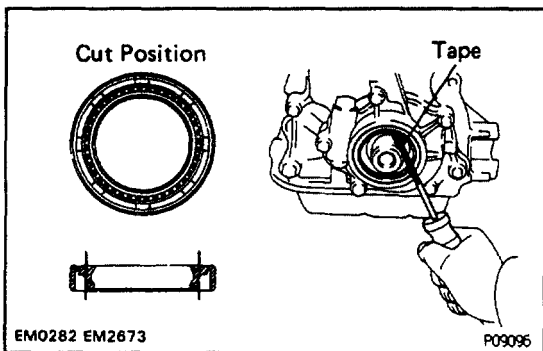

B. If timing chain cover is installed to the cylinder block:

- (a) Using a knife, cut off the oil seal lip.

- (b) Using a screwdriver, pry out the oil seal.

NOTICE: Be careful not to damage the crankshaft. Tape the screwdriver tip.

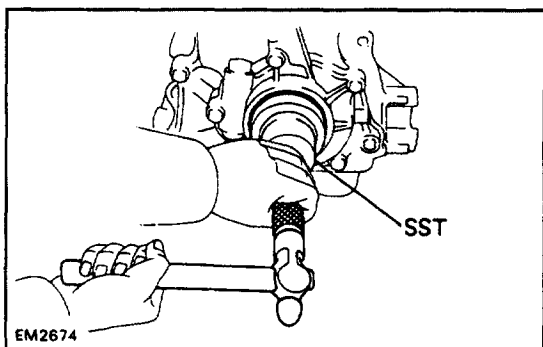

- (c) Apply MP grease to a new oil seal lip.

- (d) Using SST and a hammer, tap in the oil seal until its surface is flush with the timing chain cover edge.

SST 09223-50010

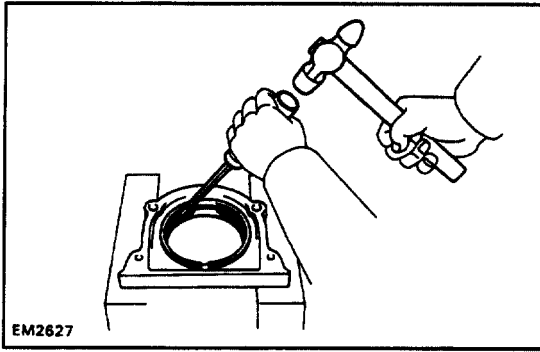

2. REPLACE CRANKSHAFT REAR OIL SEAL

A. If rear oil seal retainer is removed from cylinder block:

- (a) Using a screwdriver and hammer, tap out the oil seal.

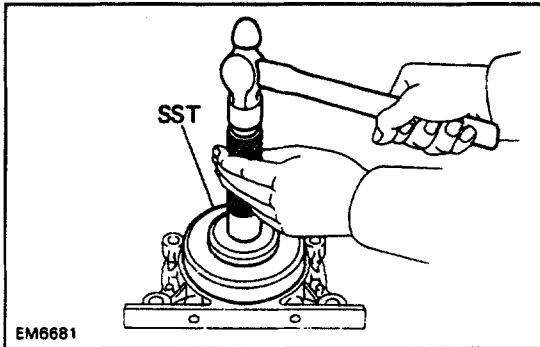

- (b) Using SST and a hammer, tap in a new oil seal until its surface is flush with the rear oil seal retainer edge.

SST 09223-41020

- (c) Apply MP grease to the oil seal lip.

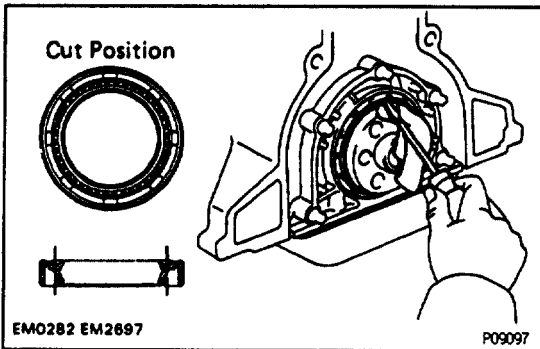

B. If rear oil seal retainer is installed to cylinder block:

- (a) Using a knife, cut off the oil seal lip.

- (b) Using a screwdriver, pry out the oil seal.

NOTICE: Be careful not to damage the crankshaft. Tape the screwdriver tip.

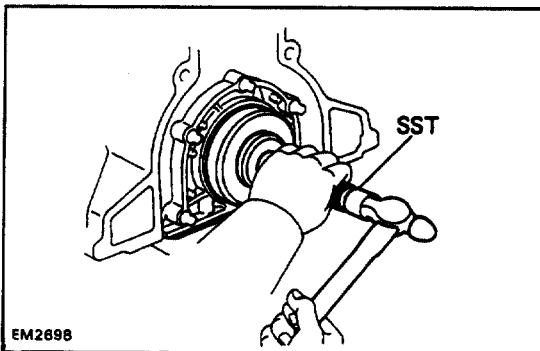

- (c) Apply MP grease to a new oil seal lip.

- (d) Using SST and a hammer, tap in the oil seal until its surface is flush with the rear oil seal retainer edge.

SST 09223-41020

SIZE	Outside Diameter mm (in.)
O/S 0.50	92.475 - 92.505 (3.6407 - 3.6419)
O/S 1.00	92.975 - 93.005 (3.6604 - 3.6616)

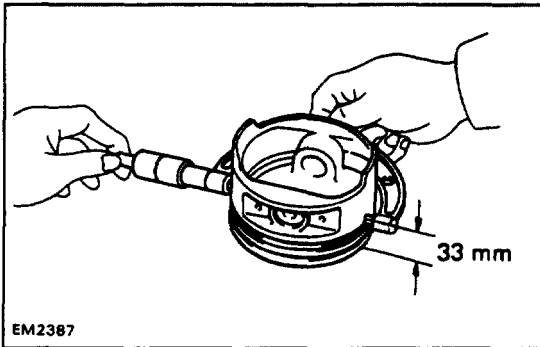

CYLINDERS BORING

1. SELECT OVERSIZED PISTON

O/S pistons with pins are available in the sizes listed. Replace pistons in matched sets. Take the largest bore measured and select the oversized piston for that bore. Bore all cylinders for the oversized piston selected.

2. CALCULATE DIMENSION TO BORE CYLINDERS

(a) Using a micrometer, measure the piston diameter at right angles to the piston pin center line, 33 mm (1.30 in.) from the piston head.

(b) Calculate the size each cylinder is to be rebored as follows:

Size to be rebored = P + C - H

P = piston diameter

C = piston clearance

0.015-0.035 mm (0.0006-0.0014 in.)

H = allowance for honing

0.02 mm (0.0008 in.) or less

3. BORE AND HONE CYLINDERS TO CALCULATED DIMENSIONS

Maximum honing:

0.02 mm (0.0008 in.)

NOTICE: Excess honing will destroy the finished roundness.

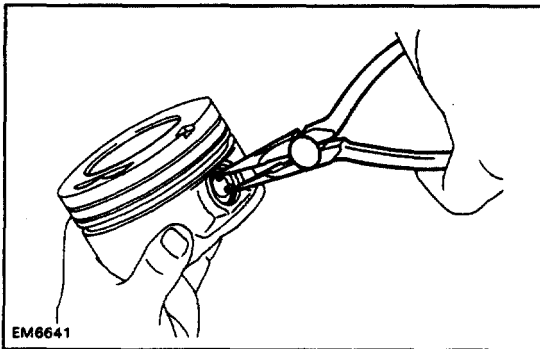

PISTON AND CONNECTING ROD ASSEMBLY

1. ASSEMBLE PISTON AND CONNECTING ROD

(a) Install a new snap ring on one side of the piston pin hole.

(b) Heat the piston in hot water to approx. 80°C (176°F).

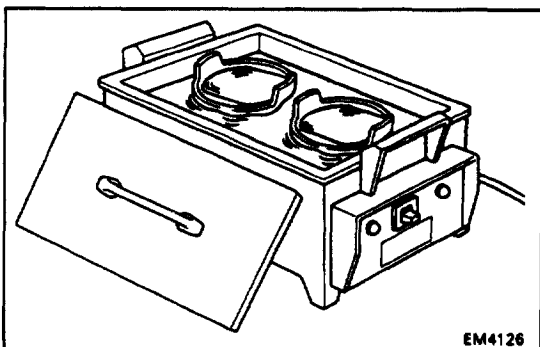

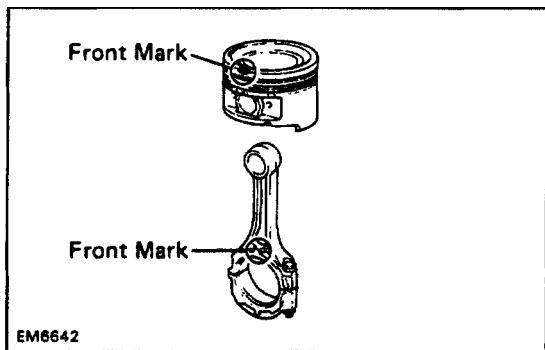

- (c) Align the notch on the piston with the mark on the rod and push the piston pin in with your thumb.
- (d) Install a new snap ring on the other side of the pin.

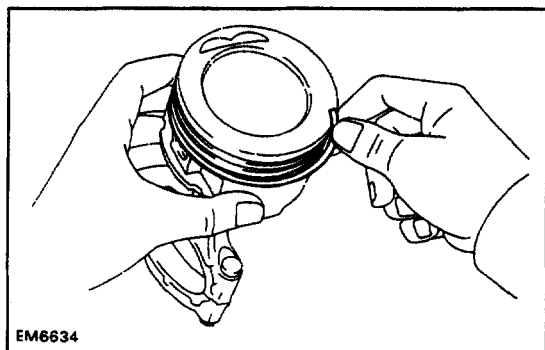

2. PLACE RINGS ON PISTON

- (a) Install the oil ring expander and 2 side rails by hand.

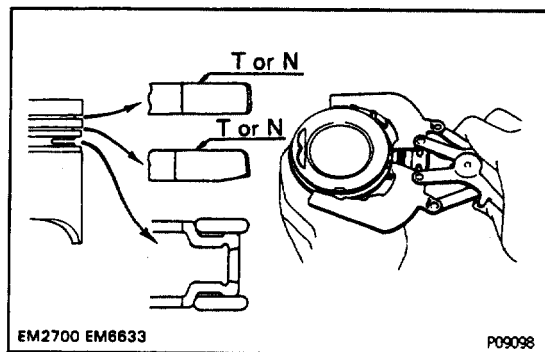

- (b) Using a ring expander, install the 2 compression rings with the code marks facing upward.

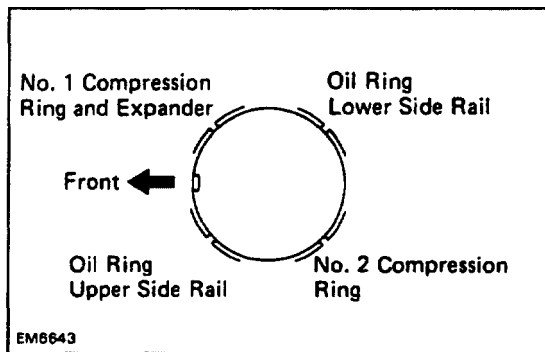

- (c) Position the piston rings so that the ring end gaps are as shown.
NOTICE: Do not align the end gaps.

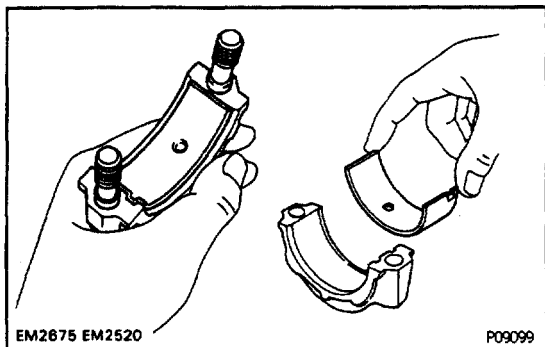

3. INSTALL BEARINGS

- (a) Install the bearing in the connecting rod and rod cap.
- (b) Lubricate the face of the bearings with engine oil.
NOTICE: Install the bearings with the oil hole in the connecting rod.

INSTALLATION OF CRANKSHAFT, PISTON AND CONNECTING ROD ASSEMBLY

(See Component)

HINT:

- Thoroughly clean all parts to be assembled.
- Before installing parts, apply new engine oil to all sliding and rotating surfaces.
- Replace all gaskets, O-ring and oil seals with new parts.

1. INSTALL MAIN BEARINGS

Install the bearing in the cylinder block and bearing caps.

NOTICE: Install the upper bearing with the oil hole in the block.

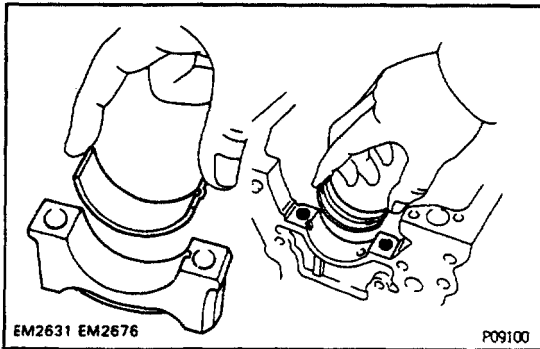

2. INSTALL UPPER THRUST WASHERS

Install the thrust washers under the No.3 main bearing cap position of the block with the oil grooves facing outward.

3. PLACE CRANKSHAFT ON CYLINDER BLOCK

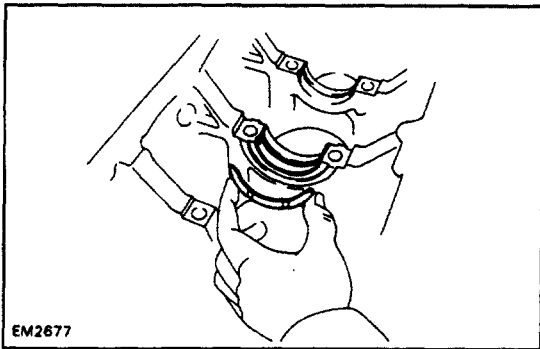

4. INSTALL MAIN BEARING CAPS WITH LOWER THRUST WASHERS

HINT: Each bearing cap is numbered.

- (a) Install the thrust washers on the No.3 bearing cap with the grooves facing outward.

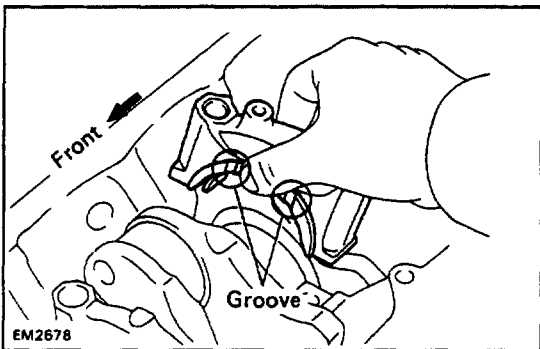

- (b) Install the bearing caps in their proper locations.

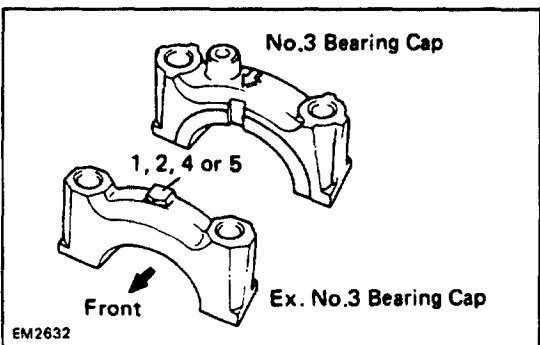

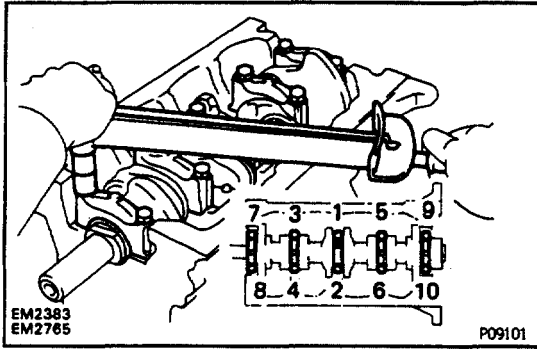

- (c) Apply a light coat of engine oil on the threads and under the cap bolt heads.
- (d) Install and tighten the cap bolts in 2 or 3 passes and in the sequence shown.

Torque: 103 N·m (1,050 kgf·cm, 76 ft·lbf)

- (e) Check that the crankshaft turns smoothly.
- (f) Check the crankshaft thrust clearance.
(See page [EG1-55](#))

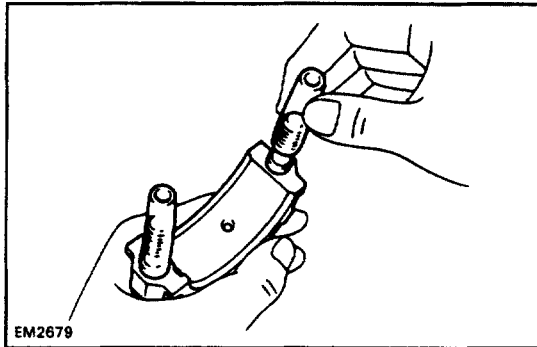

5. INSTALL PISTON AND CONNECTING ROD ASSEMBLY

- (a) Cover the rod bolts with a short piece of hose to protect the crankshaft from damage.

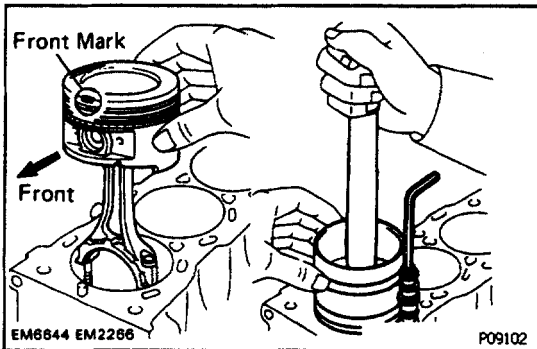

- (b) Lubricate the cylinder bore and rod journal with clean engine oil.
- (c) Using a ring compressor, tighten the compressor snugly but NOT tightly against the piston and gently tap the correctly numbered piston and rod assembly into its cylinders with a wooden hammer handle or like object. Make sure the notch and mark are facing forward.

HINT: If the ring compressor is wound too tightly around the piston, the bottom edge of the ring compressor will catch against the beveled surface at the top of the cylinder when tapping the piston in.

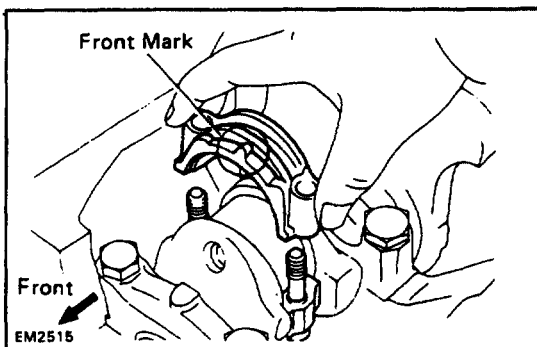

6. INSTALL CONNECTING ROD CAPS

- (a) Match the numbered cap with the numbered rod.
- (b) Install the cap with the front mark facing forward.

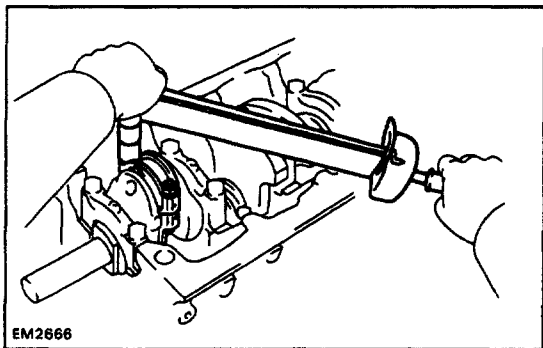

- (c) Apply a light coat of engine oil on the threads and under the rod nuts.
- (d) Install and tighten the rod nuts alternately and in 2 or 3 passes.
Torque: 69 N·m (700 kgf·cm, 51 ft·lbf)
- (e) Check that the crankshaft turns smoothly.
- (f) Check the rod thrust clearance.
(See page [EG1-52](#))

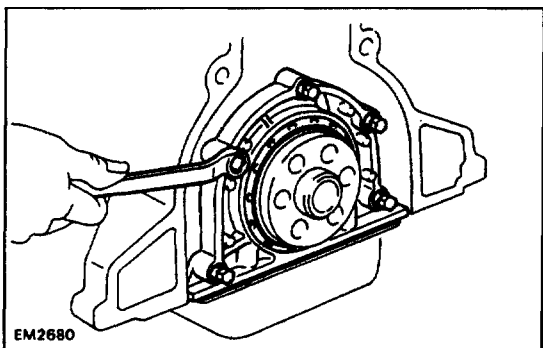

CYLINDER BLOCK ASSEMBLY

(See Components)

1. INSTALL REAR OIL SEAL RETAINER

Install a new gasket and the retainer with the 4 bolts.

Torque the bolts.

Torque: 18 N·m (180 kgf·cm, 13 ft·lbf)

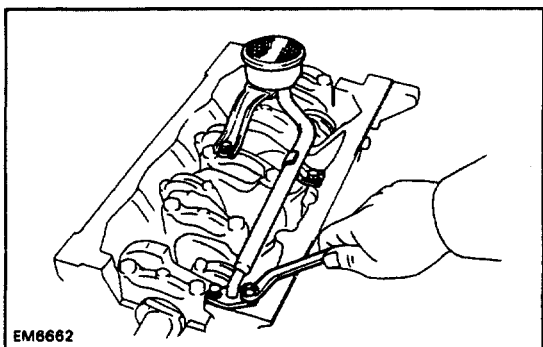

2. INSTALL OIL STRAINER

- (a) Clean the oil strainer.
- (b) Place the gasket in place and install the oil strainer assembly with the 4 bolts. Torque the bolts.
Torque: 13 N·m (130 kgf·cm, 9 ft·lbf)

3. INSTALL FUEL FILTER BRACKET AND FILTER

4. INSTALL KNOCK CONTROL SENSOR

5. INSTALL OIL PRESSURE SENDER GAUGE

6. A/T:

INSTALL FLEXIBLE HOSE CLAMP

7. INSTALL RH ENGINE MOUNTING BRACKET, CHAMBER STAY AND GROUND STRAP

8. INSTALL OIL FILTER

(See step 2 on page [EG1-242](#))

9. INSTALL CHAIN TENSIONER

Torque: 19 N·m (195 kgf·cm, 14 ft·lbf)

10. INSTALL CHAIN DAMPERS

Torque: 22 N·m (220 kgf·cm, 16 ft·lbf)

11. INSTALL GENERATOR BRACKET AND LH ENGINE MOUNTING BRACKET

12. INSTALL TIMING CHAIN (See page [EG1-44](#))

13. INSTALL GENERATOR

14. INSTALL CYLINDER HEAD (See page [EG1-34](#))

15. REMOVE ENGINE STAND

16. INSTALL REAR END PLATE**17. INSTALL FLYWHEEL OR DRIVE PLATE**

Install the flywheel (M/T) or spacer, drive plate, spacer (A/T) on the crankshaft with the 6 bolts.

Torque the bolts.

Torque:

108 N·m (1,100 kgf·cm, 80 ft·lbf) for M/T

83 N·m (850 kgf·cm, 61 ft·lbf) for A/T

ENGINE INSTALLATION**1. M/T:**

**INSTALL CLUTCH DISC AND COVER TO FLYWHEEL
(See CL section)**

2. CONNECT TRANSMISSION TO ENGINE**3. PLACE ENGINE WITH TRANSMISSION IN VEHICLE**

(a) Attach the engine hoist chain to the lifting brackets on the engine.

(b) Lower the engine with transmission into the engine compartment.

4. 4WD:

PLACE JACK UNDER TRANSMISSION

Be sure to put a wooden block between the jack and the transmission pan.

5. JACK UP AND PUT TRANSMISSION ONTO MEMBER**6. INSTALL ENGINE MOUNTING TO FRAME BRACKET**

(a) Align the engine mounting and frame bracket.

(b) Install the engine mounting bolts on each side of the engine.

(c) Remove the hoist chain.

7. 2WD:

INSTALL ENGINE REAR MOUNTING AND BRACKET

(a) Raise the transmission slightly by raising the engine with a jack and a wooden block under the transmission.

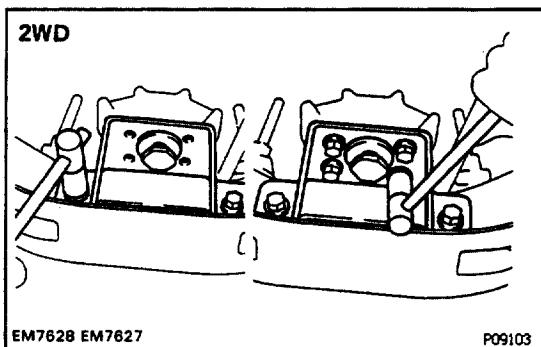

(b) Install the engine rear mounting bracket to the support member. Torque the 2 bolts.

Torque: 13 N·m (130 kgf·cm, 9 ft·lbf)

(c) Lower the transmission and rest it on the extension housing.

(d) Install the bracket to the mounting. Torque the 4 bolts.

Torque: 25 N·m (260 kgf·cm, 19 ft·lbf)

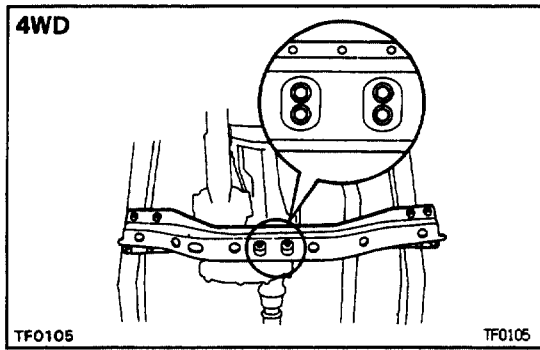
**4WD:****INSTALL NO.2 FRAME CROSSMEMBER**

- (a) Raise the transmission slightly with a jack.
- (b) Install the No.2 frame crossmember to the side frame with the 4 bolts. Torque the bolts.
Torque: 95 N·m (970 kgf·cm, 70 ft·lbf)
- (c) Lower the transmission and transfer.
- (d) Install the 4 mounting bolts to the engine rear mounting.
Torque: 13 N·m (130 kgf·cm, 9 ft·lbf)

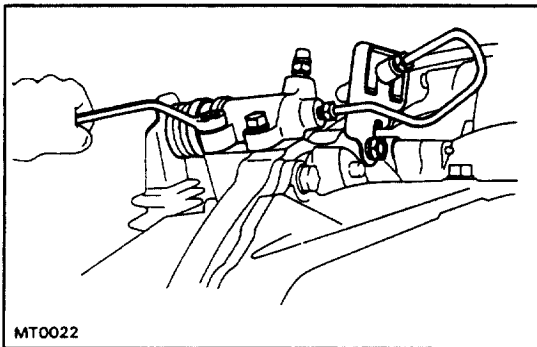
8. 4WD:**INSTALL BRAKE TUBE HEAT INSULATOR AND NO. 1 FRONT FLOOR HEAT INSULATOR****9. M/T:****INSTALL CLUTCH RELEASE CYLINDER WITH BRACKET TO TRANSMISSION****Torque:**

- 39 N·m (400 kgf·cm, 29 ft·lbf) for Bracket**
- 12 N·m (120 kgf·cm, 9 ft·lbf) for Release cylinder**

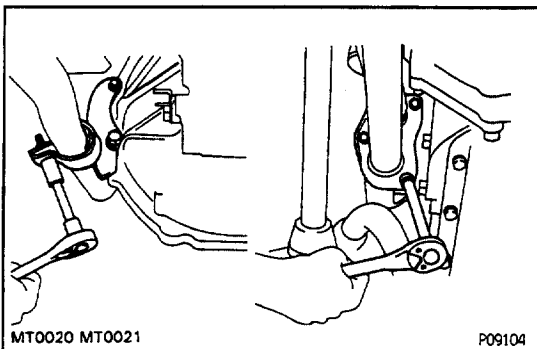
**10. INSTALL EXHAUST PIPE**

- (a) Connect the exhaust pipe to the catalytic converter.
- (b) Connect the exhaust pipe to the exhaust manifold.
- (c) Install the exhaust pipe clamp.
- (d) Connect the oxygen sensor connector.

11. INSTALL NO.1 FRAME CROSSMEMBER**12. 4WD:****INSTALL FRONT PROPELLER SHAFT
(See PR section)****13. 4WD:****INSTALL STABILIZER BAR
(See SA section)****14. 4WD:****INSTALL TRANSFER UNDER COVER****15. CONNECT SPEEDOMETER CABLE**

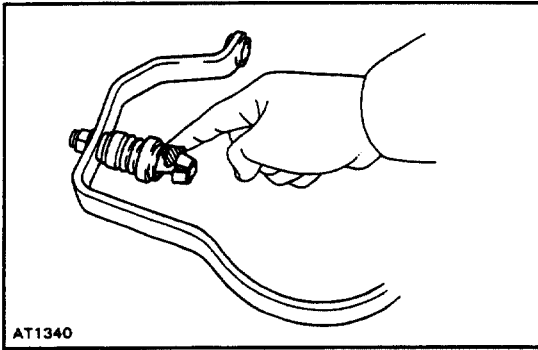

- 16. 4WD A/T:
CONNECT TRANSFER SHIFT LINKAGE**
- (a) Apply MP grease to the cross shaft joint.

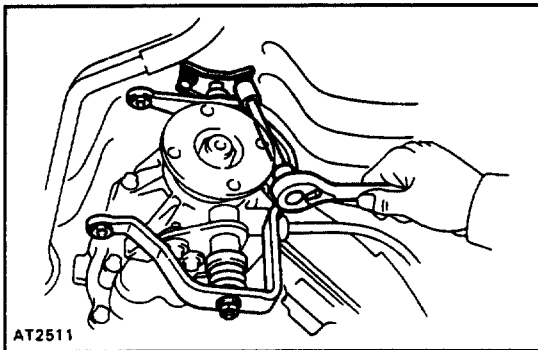

- (b) Install the cross shaft to the body.

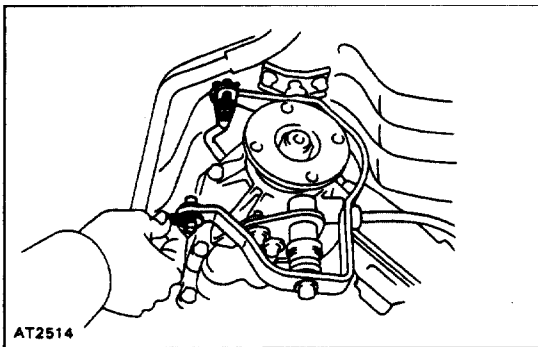

- (c) Connect the No.1 and No.2 transfer shift linkage to the cross shaft.

- 17. A/T:
CONNECT MANUAL SHIFT LINKAGE TO PNP SWITCH**
- 18. INSTALL PROPELLER SHAFT
(See PR section)**
- 19. R150:
INSTALL SHIFT LEVER RETAINER**

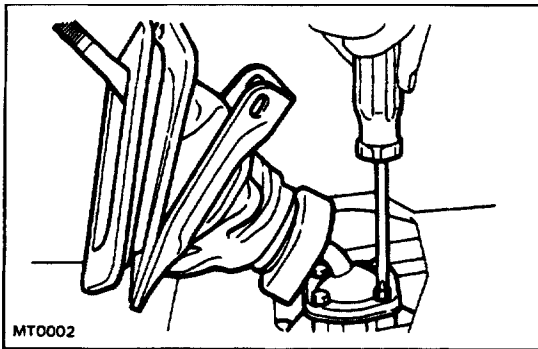

- 20. M/T:
INSTALL SHIFT LEVER**
- (a) Apply MP grease to the shift lever.
- (b) Install the shift lever to the transmission.

- 21. CONNECT GROUND STRAPS TO ENGINE REAR SIDE
AND RH SIDE**

- 22. w/ A/C:
INSTALL COMPRESSOR TO BRACKET**

- (a) Install the compressor with the 4 bolts.
- (b) Install the drive belt and adjust the belt tension.

- 23. CONNECT GROUND STRAP FOR PS PUMP BRACKET**

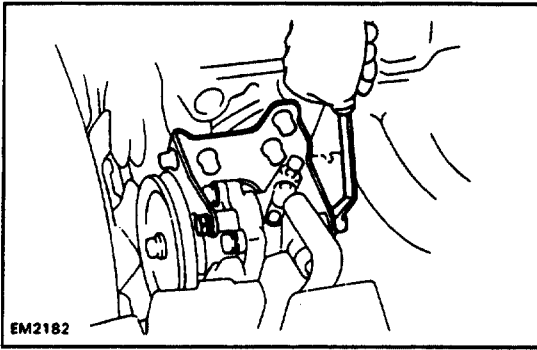

- 24. w/PS:**
INSTALL PS PUMP WITH PS PUMP BRACKET
 Install the PS pump with the 4 bolts.

25. CONNECT FOLLOWING CABLES:

- (a) A/T:
Throttle cable
- (b) w/ Cruise control:
Cruise control cable
- (c) Accelerator cable

26. CONNECT FOLLOWING HOSES:

- (a) Charcoal canister hose to canister
- (b) w/ Cruise control:
Cruise control vacuum hose
- (c) Brake booster hose
- (d) PS air hoses to gas filter and air pipe

27. CONNECT FOLLOWING WIRES AND CONNECTORS:

- (a) w/ A/C:
A/C compressor connector
- (b) Check connector
- (c) M/T:
Starter relay connectors
- (d) ECM connectors
- (e) Ground strap to engine rear side
- (f) Distributor wire
- (g) High-tension cords
- (h) Generator wires
- (i) Igniter connector
- (j) Generator connector and wire
- (k) Ground strap to LH fender apron

**28. INSTALL FAN PULLEY, BELT GUIDE, FLUID COUPLING
 AND GENERATOR DRIVE BELT**
 (See step 9 on page [EG1-45](#))

- 29. w/ A/C:**
INSTALL A/C BELT
 (See step 2 on page [MA-8](#))

30. INSTALL PS PUMP AND BELT

- (a) Place the PS drive belt onto each pulley.
- (b) Stretch the belt tight and tighten the nuts.
- (c) Torque the PS pump pulley lock nut.

Torque: 43 N·m (440 kgf·cm, 32 ft·lbf)

- (d) Adjust the belt tension.

(See step 2 on page [MA-8](#))

31. INSTALL RADIATOR**32. INSTALL AIR CLEANER CASE AND INTAKE AIR CONNECTOR****33. FILL WITH ENGINE OIL**

(See step 3 on page [EG1-242](#))

34. FILL WITH COOLANT

(See step 3 on page [EG1-233](#))

35. INSTALL ENGINE UNDER COVER**36. INSTALL BATTERY****37. INSTALL HOOD****38. START ENGINE**

Warm up the engine and inspect for leaks.

39. PERFORM ENGINE ADJUSTMENT

(See page [EG1-10](#))

40. ROAD TEST

Road test the vehicle.

41. RECHECK COOLANT AND ENGINE OIL LEVEL