



1KZ-T ENGINE

REPAIR MANUAL

May, 1993

THE FOLLOWING FUEL SECTION
HAS BEEN EXTRACTED FROM
THIS MANUAL

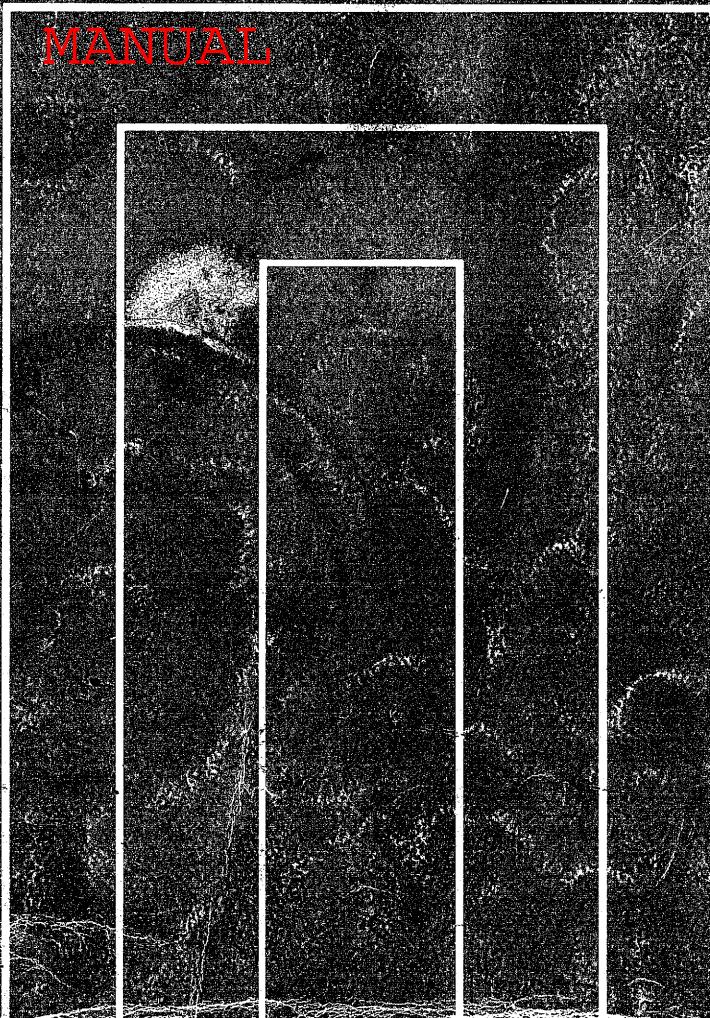

SERVICE SPECIFICATIONS

SERVICE DATA

EGOXE-03

Turbocharger	Turbocharging pressure		51 — 67 kPa (0.52 — 0.68 kgf/cm ² , 7.4 — 9.7 psi)
	Impeller wheel axial play	Maximum	0.173 mm (0.0068 in.)
	Impeller wheel radial play	Maximum	0.110 mm (0.0045 in.)
Turbocharger pressure sensor	Voltage		4.75 — 5.25 V

EGOXE-05

TORQUE SPECIFICATIONS

Part tightened		N·m	kgf·cm	ft·lbf
Turbine inlet elbow x Turbocharger		19	195	14
Turbo water pipe x Turbocharger	Nut	12	120	9
	Bolt	8	80	69 in.-lbf
Turbocharger x Exhaust manifold		52	530	38
Oil pipe x Turbocharger		19	195	14
Exhaust manifold x Cylinder block		52	530	38
Oil pipe x Cylinder block	Union bolt	26	260	19
	Bolt	12	125	12
Turbocharger stay x Turbocharger		19	195	14
Turbocharger stay x Cylinder block		19	195	14
Turbine outlet elbow x Turbocharger		39	390	28
Exhaust manifold heat insulator x Exhaust manifold		8	80	69 in.-lbf
Turbocharger heat insulator x Turbocharger		8	80	69 in.-lbf
Intake pipe x Intake manifold		11	120	9

FUEL SYSTEM

DESCRIPTION

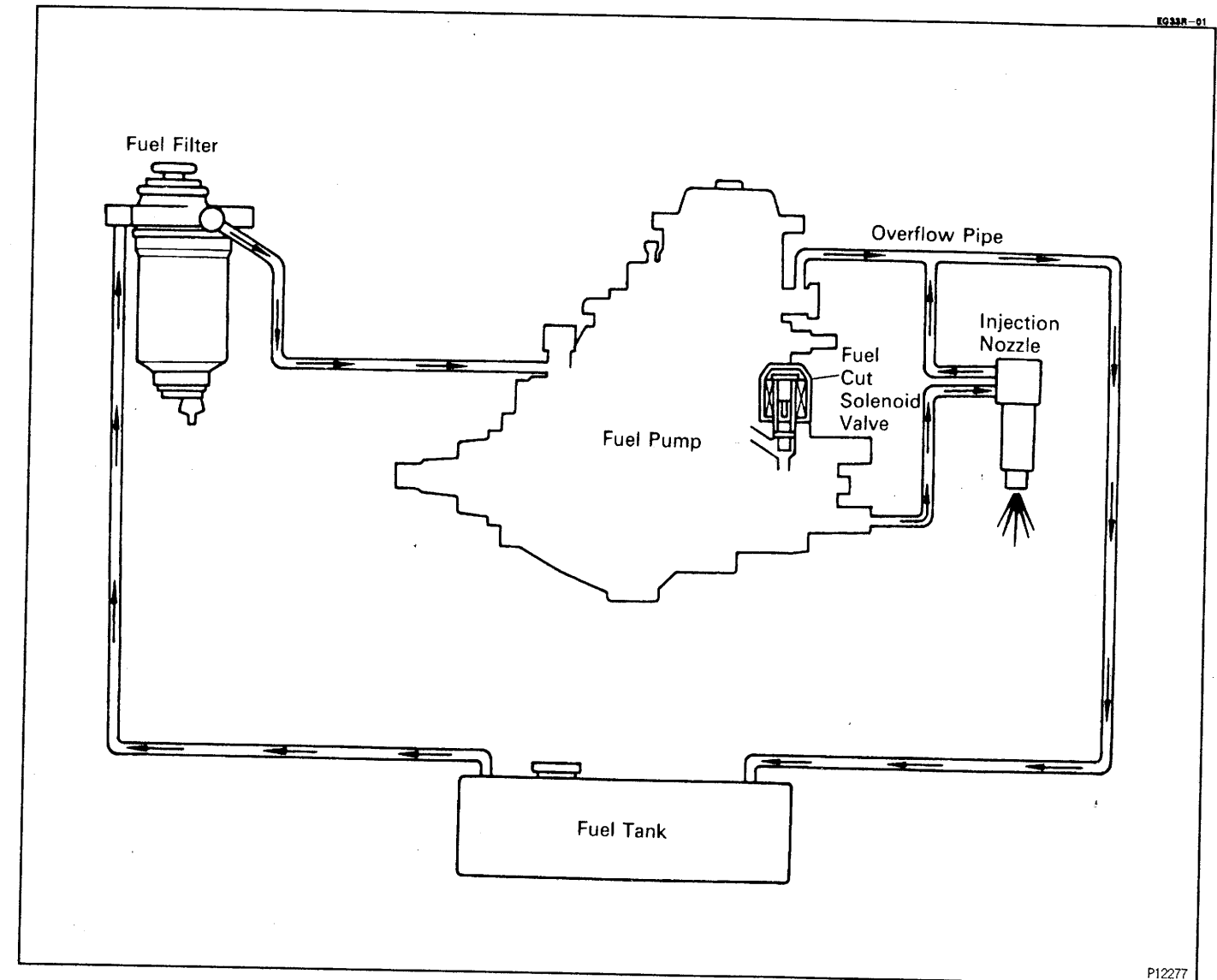

FUEL SYSTEM

Fuel is drawn up from the fuel tank through the fuel filter (sedimentator) by the feed pump built into the injection pump. The fuel drawn up is then sent into the pump housing. High pressure fuel from the pump housing is distributed to the injection nozzles according to the injection order, and injected at high pressure into the combustion chamber. Excess fuel in the pump housing flows through the overflow valve and along the overflow pipe and returns to the fuel tank. The fuel cycle provides both cooling and lubrication for the pump. The cycling of fuel through the pump chamber warms the fuel so that it is prevented from becoming wax-like at cold temperatures.

OPERATION

Injection Pump (VE pump)

EG318-01

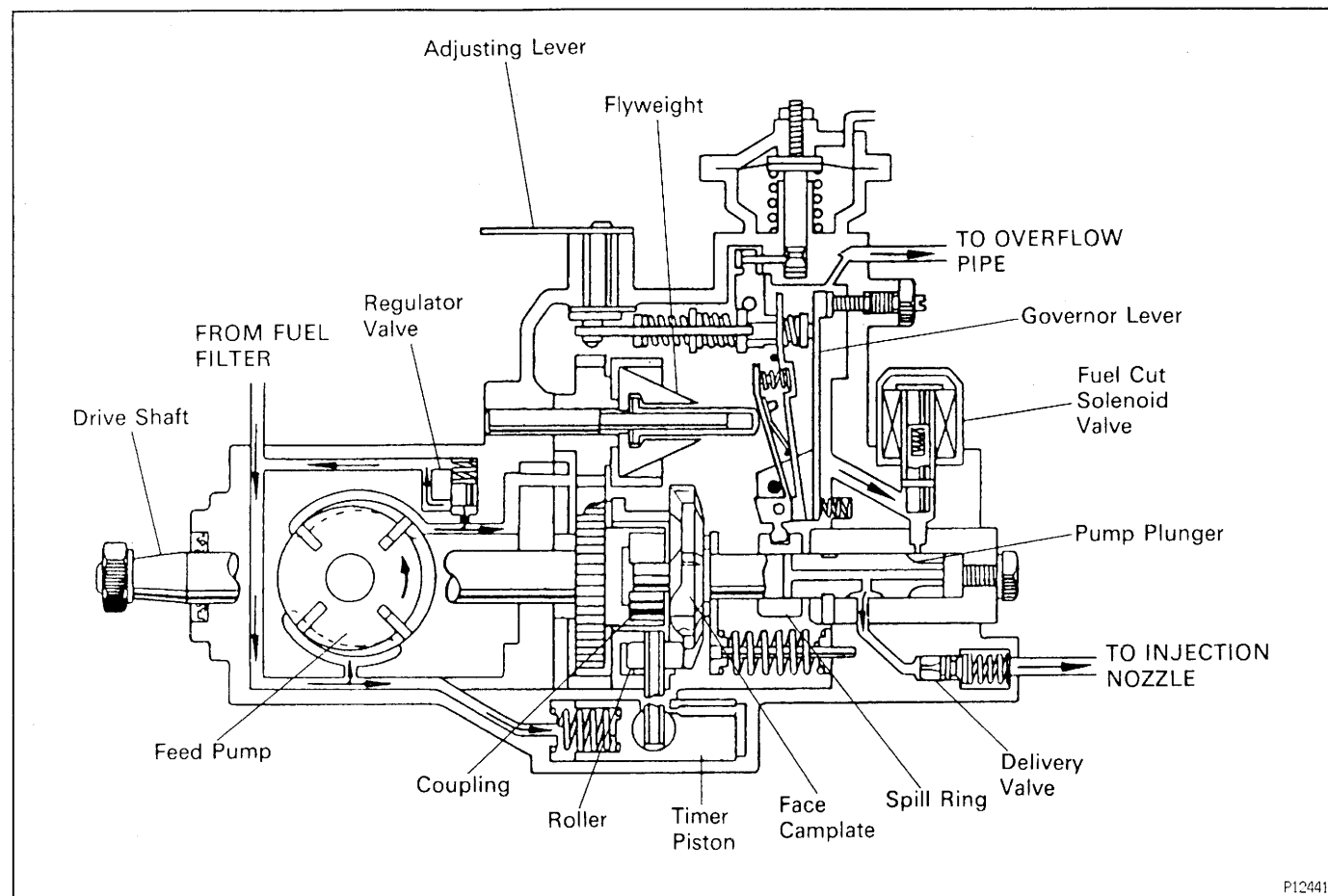









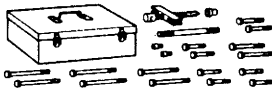

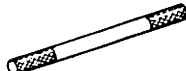
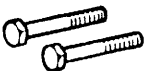
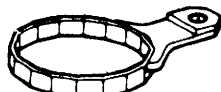





- The centrifugal type feed pump takes up a fixed volume of fuel with each turn. The fuel expulsion pressure from the feed pump is controlled by operation of the pressure regulator valve.
- Fuel is sent from the outlet side of the feed pump, through the hole in the upper part of the feed pump cover and into the pump body.
- The pump plunger also rotates as it moves up and down. After the fuel is drawn in, it is distributed under pressure to the delivery valve of each cylinder according to the injection order.
- The centrifugal force type minimum/maximum governor installed in the upper part of the injection pump moves the spill ring obstructing the plunger spill port and controls the fuel injection volume.
- The hydraulic type timer installed in the lower part of the injection pump is operated by the fuel pressure of the pump housing, and movement of the roller ring by the timer advances the injection angle and controls the injection timing.
- The fuel cut solenoid valve is connected to the ignition switch IG circuit, and when the ignition switch is turned to OFF, the current is cut off, the solenoid is de-energized, fuel is cut off and the engine stops.
- High Altitude Compensation (HAC) Device
Due to the decrease in atmospheric pressure at high altitudes, the air fuel ratio becomes more dense and the smoke density increases. To prevent this, the device automatically reduces the fuel injection volume for full loads in response to the altitude.

- Boost Compensator with turbocharger
The boost compensator is installed on the upper part of the governor of the injection pump. Turbocharged air pressure moves the diaphragm and push rod up and down, this movement is conveyed to the spill ring and the fuel injection volume increases according to the degree of movement.

PREPARATION
SST (SPECIAL SERVICE TOOLS)

EGOCF-0E

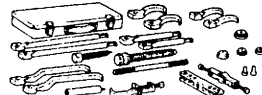
	09213-60017 Crankshaft Pulley & Gear Puller Set	
	(09213-00020) Body With Bolt	
	(09213-00030) Handle	
	(09213-00060) Bolt Set	
	09228-64010 Fuel Filter Wrench	
	09236-00101 Water Pump Overhaul Tool Set	
	(09237-00070) Shaft "C"	Governor sleeve plug
	09241-76022 Injection Pump Stand Set	
	(09241-76010) Injection Pump Stand	
	09260-54012 Injection Pump Tool Set	
	(09262-54010) Distributor Head Plug Wrench	
	(09269-54020) Socket 14 mm	
	(09269-54030) Tweezers	

	(09269-54040) Governor Lever Support Bolt Wrench	
	(09262-54020) Regulator Valve Wrench	
	09268-64010 Injection Nozzle Wrench Set	
	(09268-64020) Injection Nozzle Holder Retaining Nut Wrench	
	09950-20017 Universal Puller	
	09992-00241 Turbocharger Pressure Gauge	

EQUIPMENT

EGOCH-0E

Angle gauge	
Brass brush	
Dial indicator with magnetic base	
Graduated cylinder	
Injection nozzle tester	
Injection pump tester	
Inner pressure gauge	
Ohmmeter	
Thickness gauge	
Timer measuring device	
Torque wrench	
Wooden stick	

FUEL FILTER**1. DISCONNECT FUEL FILTER WARNING SWITCH CONNECTOR****2. DRAIN FUEL FROM FUEL FILTER**

- (a) Connect a vinyl hose to the drain cock, and insert the other end of the vinyl hose in a container.
- (b) Loosen the drain plug, and drain the fuel.

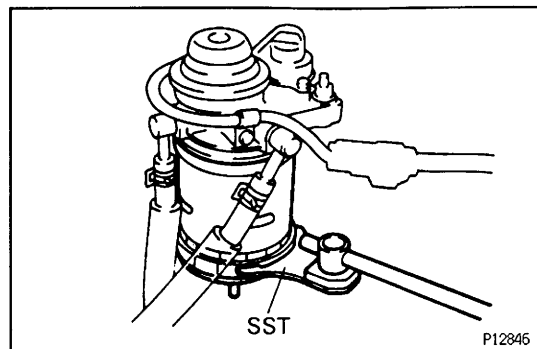
**3. REPLACE FUEL FILTER****A. Remove fuel filter**

Using SST, remove the fuel filter.
SST 09228-64010

- B. Remove fuel filter warning switch from fuel filter**
Using pliers, remove the warning switch and O-ring.
NOTICE: Be careful not to damage the warning switch.

C. Install fuel filter warning switch to new fuel filter

- (a) Install a new O-ring to the warning switch.
- (b) Apply fuel to the O-ring of the warning switch.

- (c) Install the warning switch to a new fuel filter by hand.

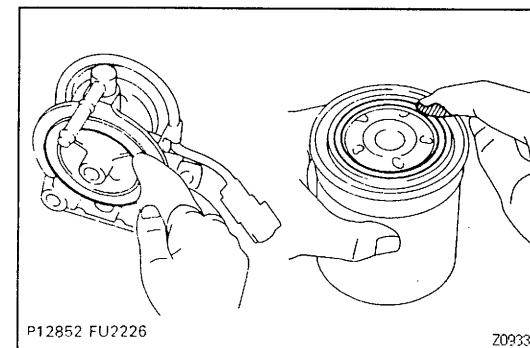
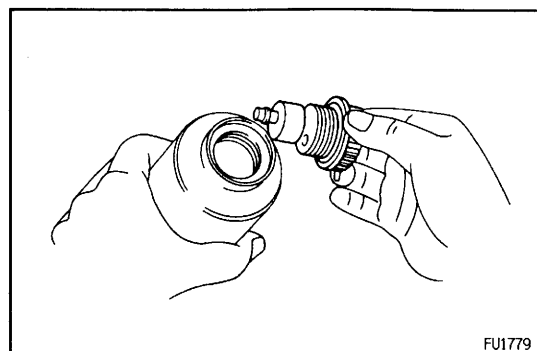
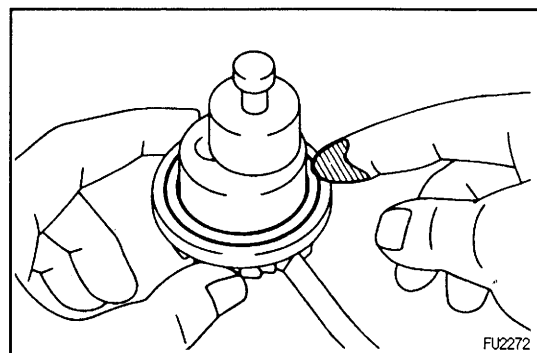
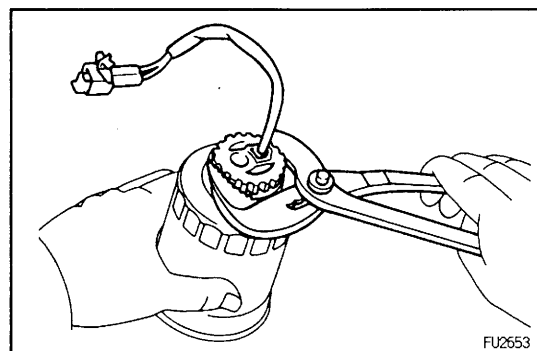
**D. Install new fuel filter**

- (a) Check and clean the fuel filter installation surface.
- (b) Apply fuel to the gasket of a new fuel filter.

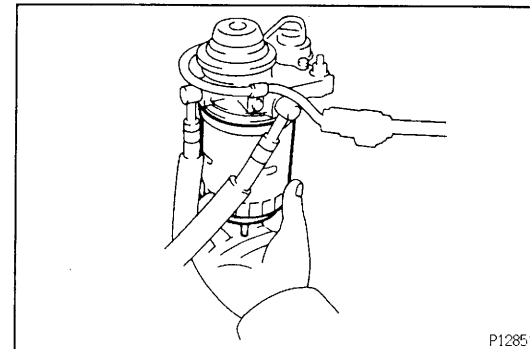

- (c) Lightly screw the fuel filter into place, and tighten it until the gasket comes into contact with the seat.
- (d) Tighten it additional 3/4 turn by hand.

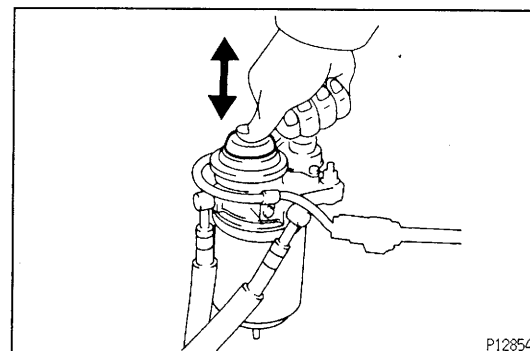
**4. FILL FUEL FILTER WITH FUEL**

Operate the hand pump until you feel more resistance.

5. CONNECT FUEL FILTER WARNING SWITCH CONNECTOR**6. START ENGINE AND CHECK FOR FUEL LEAKS**

FUEL HEATER SYSTEM SYSTEM CIRCUIT

EG33U-01

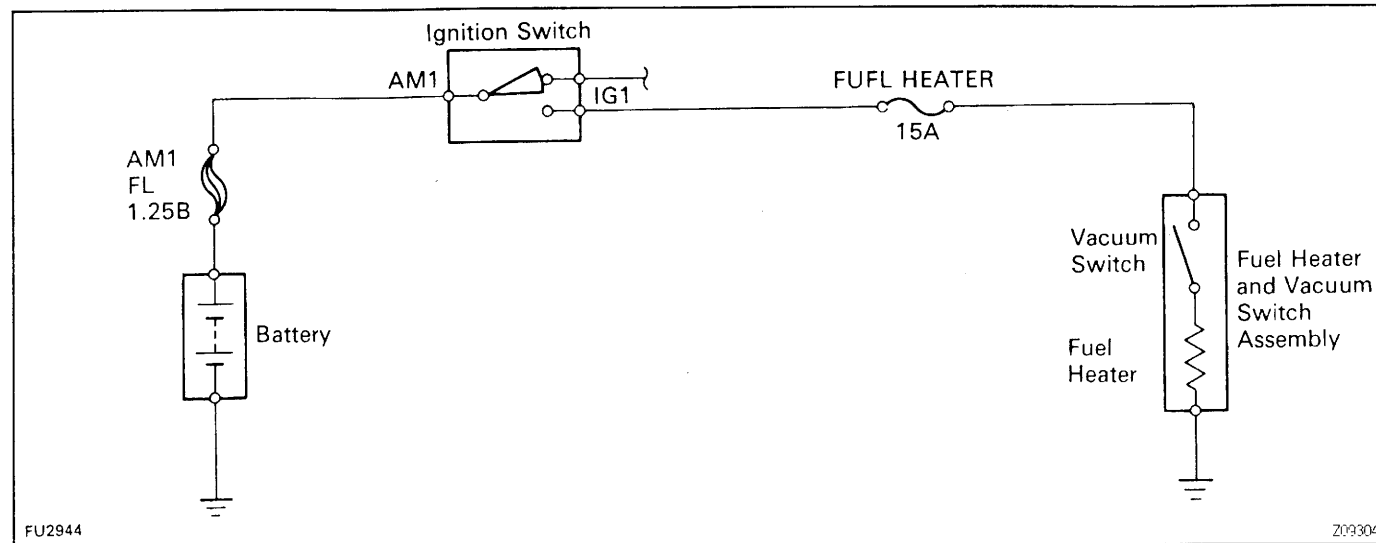

FU2944

Z09304

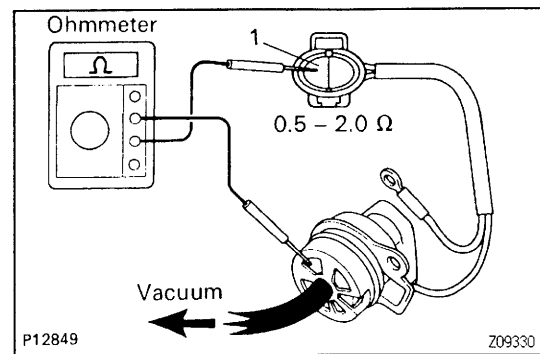

P12849

Z09330

COMPONENTS INSPECTION

Fuel Heater

INSPECT FUEL HEATER

- Apply a vacuum of 34.7 ± 5.3 kPa (260 ± 40 mmHg, 10.24 ± 1.57 in.Hg) or more to the vacuum switch port.
- Using an ohmmeter, measure the resistance between terminal 1 and the switch body.

Resistance:

1.4 – 2.0 Ω at 20°C (68°F)

If the resistance is not as specified, replace the fuel heater and vacuum switch assembly.

EG33V-01

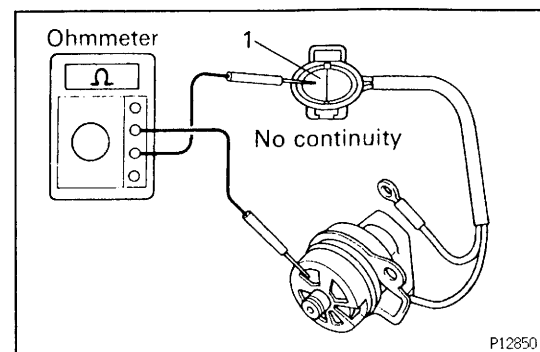

P12850

Vacuum Switch

1. INSPECT SWITCH CONTINUITY

Using an ohmmeter, check that there is no continuity between terminal 1 and the switch body.

If continuity is not as specified, replace the fuel heater and vacuum switch assembly.

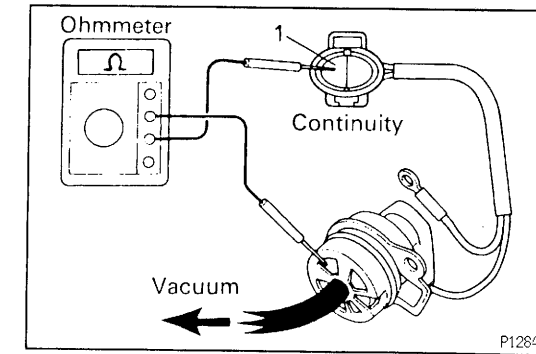

P12849

2. INSPECT SWITCH OPERATION

- Apply a vacuum of 34.7 ± 5.3 kPa (260 ± 40 mmHg, 10.24 ± 1.57 in.Hg) or more to the vacuum switch port.
- Using an ohmmeter, check that there is continuity between terminal 1 and the switch body. If operation is not as specified, replace the fuel heater and vacuum switch assembly.

INJECTION NOZZLE COMPONENTS FOR REMOVAL AND INSTALLATION

EG33W-01

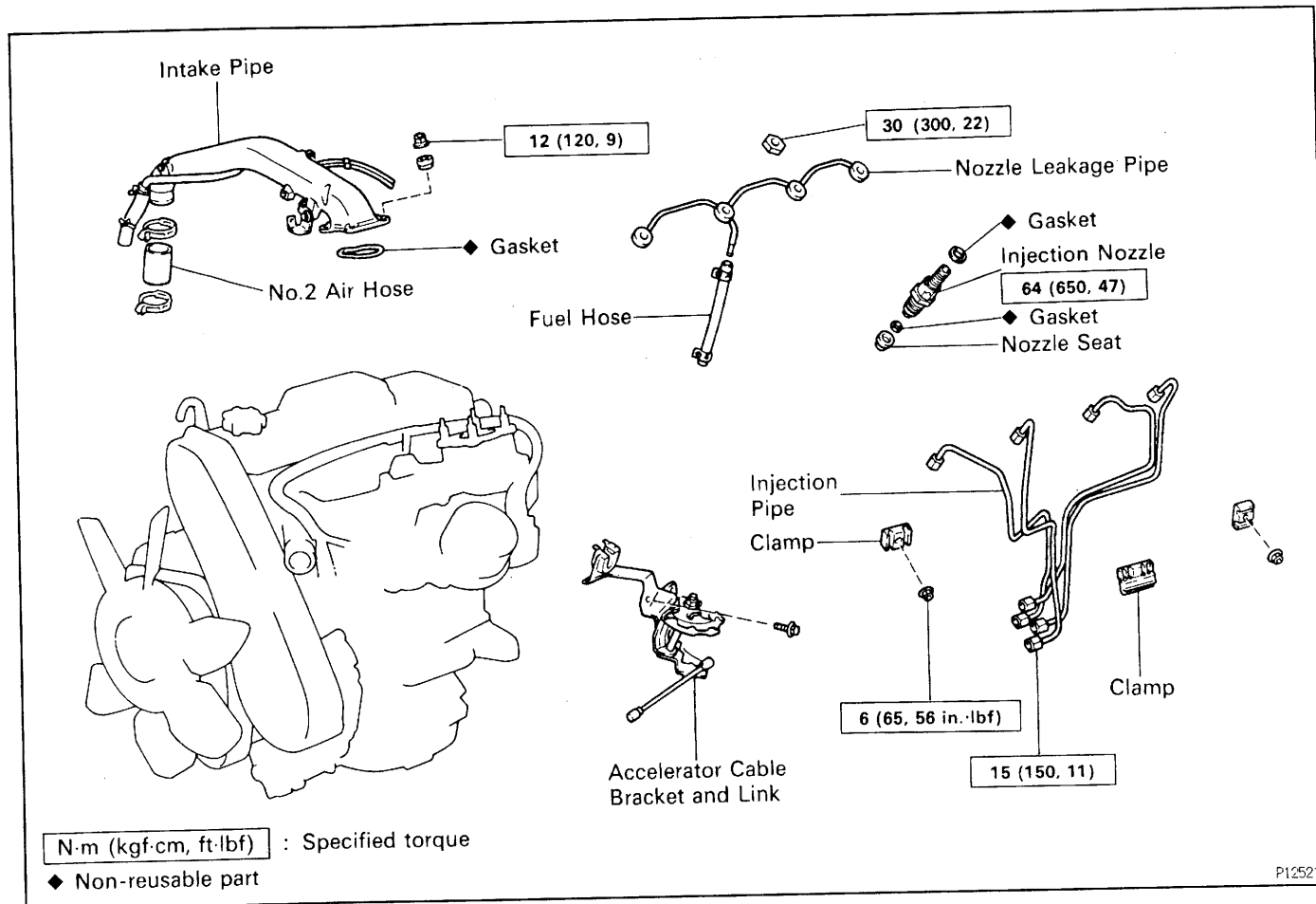

P12521

INJECTION NOZZLES REMOVAL

EG33X-01

1. REMOVE INTAKE PIPE

- Disconnect the VSV connector and 2 vacuum hoses.
- Disconnect the 2 wire harness clamps.
- Remove the 4 nuts and seal washers.

- Disconnect the 2 PCV hoses.
- Use pliers to pinch the ends of the clamp together until the lock plate engages the catch. Make sure the lock plate and catch are engaged securely.
- Remove the intake pipe and gasket.

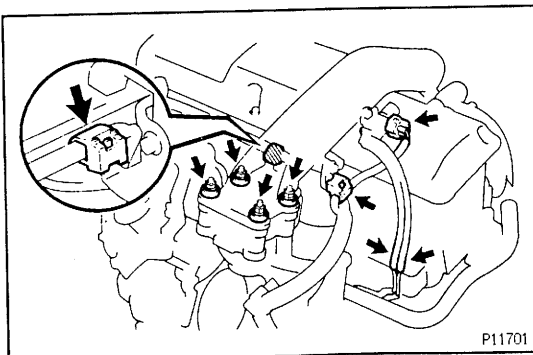

P11701

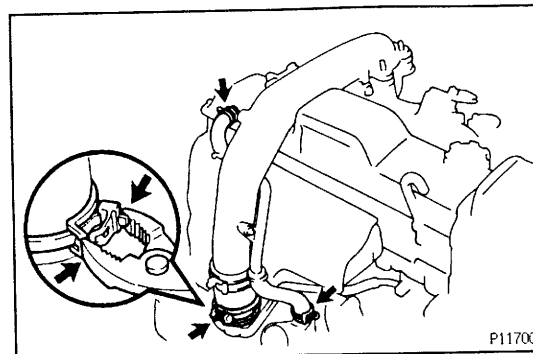

P11700

2. REMOVE ACCELERATOR CABLE BRACKET AND LINK

- Disconnect the accelerator link from the injection pump.
- Remove the 3 bolts and accelerator cable bracket and link.

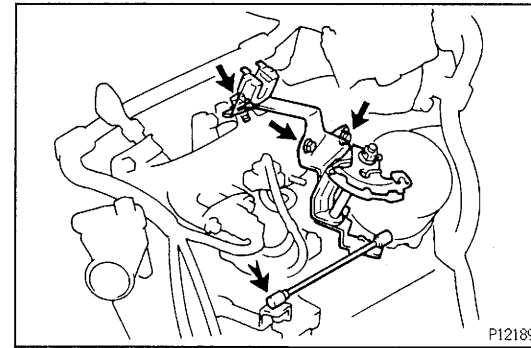

P12189

3. REMOVE INJECTION PIPES

- Remove the 2 nuts holding the clamps (A) to the intake manifold.
- Using a screwdriver, pry out the clamp (B).

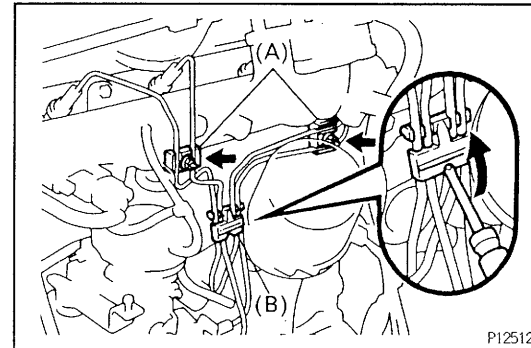

P12512

- Loosen the 8 union nuts of the injection pipes.
- Remove the 4 injection pipes and 2 clamps (A).

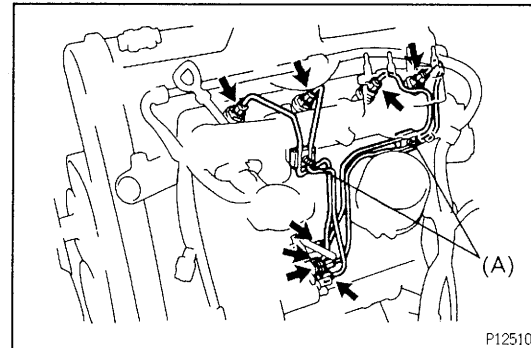

P12510

4. REMOVE NOZZLE LEAKAGE PIPE

- Disconnect the fuel hose from the return pipe.
- Remove the 4 nuts, leakage pipe and 4 gaskets.

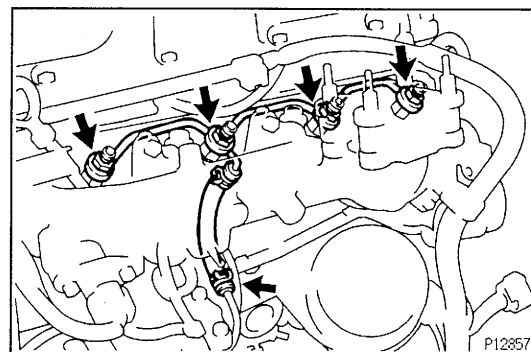

P12857

5. REMOVE INJECTION NOZZLES

Using SST, remove the 4 injection nozzles, gaskets and seats.

SST 09268-64010 (09268-64020)

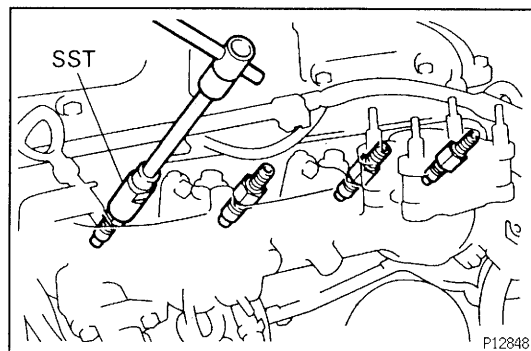

P12848

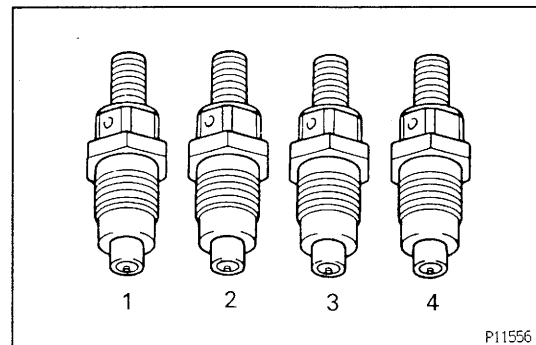

P11556

HINT: Arrange the injection nozzles in correct order.

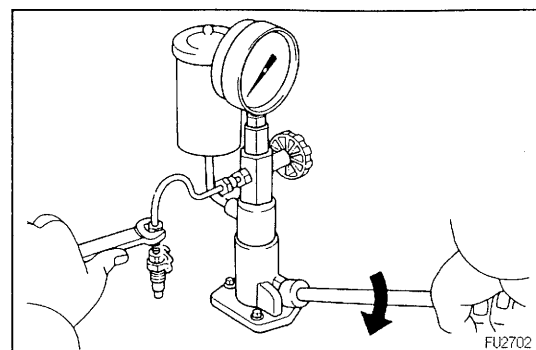

FU2702

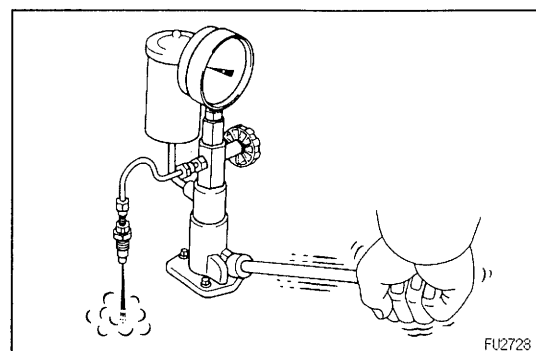

FU2728

INJECTION NOZZLES TEST

EG33Y-01

1. INJECTION PRESSURE TEST

- (a) Install the injection nozzle to the injection nozzle hand tester and bleed air from the union nut.

CAUTION: Do not place your finger over the nozzle injection hole.

- (b) Pump the tester handle a few times as fast as possible to discharge the carbon from the injection hole.
 (c) Pump the tester handle slowly and observe the pressure gauge.
 (d) Read the pressure gauge just as the injection pressure begins to drop.

Opening pressure:

New nozzle

14,808 — 15,593 kPa
 (151 — 159 kgf/cm²)
 (2,148 — 2,261 psi)

Reused nozzle

14,710 — 15,593 kPa
 (150 — 159 kgf/cm²)
 (2,133 — 2,261 psi)

HINT: Proper nozzle operation can be determined by a swishing sound.

If the opening pressure is not as specified, disassemble the nozzle holder and change the adjusting shim on the top of the pressure spring. (See page EG — 156).

Adjusted opening pressure:

14,710 — 15,593 kPa
 (150 — 159 kgf/cm²)
 (2,133 — 2,261 psi)

Adjusting shim thickness		mm (in.)
0.900 (0.0354)	1.275 (0.0502)	1.650 (0.0650)
0.925 (0.0364)	1.300 (0.0512)	1.675 (0.0659)
0.950 (0.0374)	1.325 (0.0522)	1.700 (0.0669)
0.975 (0.0384)	1.350 (0.0531)	1.725 (0.0679)
1.000 (0.0394)	1.375 (0.0541)	1.750 (0.0689)
1.025 (0.0404)	1.400 (0.0551)	1.775 (0.0699)
1.050 (0.0413)	1.425 (0.0561)	1.800 (0.0709)
1.075 (0.0423)	1.450 (0.0571)	1.825 (0.0719)
1.100 (0.0433)	1.475 (0.0581)	1.850 (0.0728)
1.125 (0.0443)	1.500 (0.0591)	1.875 (0.0738)
1.150 (0.0453)	1.525 (0.0600)	1.900 (0.0748)
1.175 (0.0463)	1.550 (0.0610)	1.925 (0.0758)
1.200 (0.0472)	1.575 (0.0620)	1.950 (0.0768)
1.225 (0.0482)	1.600 (0.0630)	
1.250 (0.0492)	1.625 (0.0640)	

V03745

HINT:

- Varying the adjusting shim thickness by 0.025 mm (0.0010 in.) changes the injection pressure by about 471 kPa (4.8 kgf/cm², 68 psi).
 - Only one adjusting shim should be used.
- (e) There should be no dripping after injection.

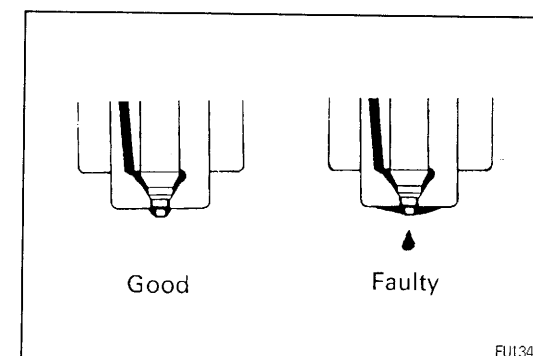

FU1347

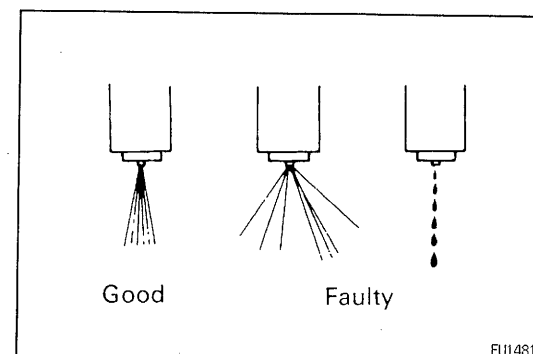

FU1481

2. LEAKAGE TEST

While maintaining pressure at about 981 — 1,961 kPa (10 — 20 kgf/cm², 142 — 284 psi) below opening pressure (adjust by tester handle), check that there is no dripping for 10 seconds from the injection hole or around the retaining nut.

If the nozzle drips within 10 seconds, replace or clean and overhaul the nozzle assembly.

3. SPRAY PATTERN TEST

- (a) The injection nozzle should shudder at a certain pumping speed between 15 — 60 times (old nozzle) or 30 — 60 times (new nozzle) per minute.
 (b) Check the spray pattern during shuddering. If the spray pattern is not correct during shuddering, the nozzle must be replaced or cleaned.

COMPONENTS FOR DISASSEMBLY AND ASSEMBLY

EG332-01

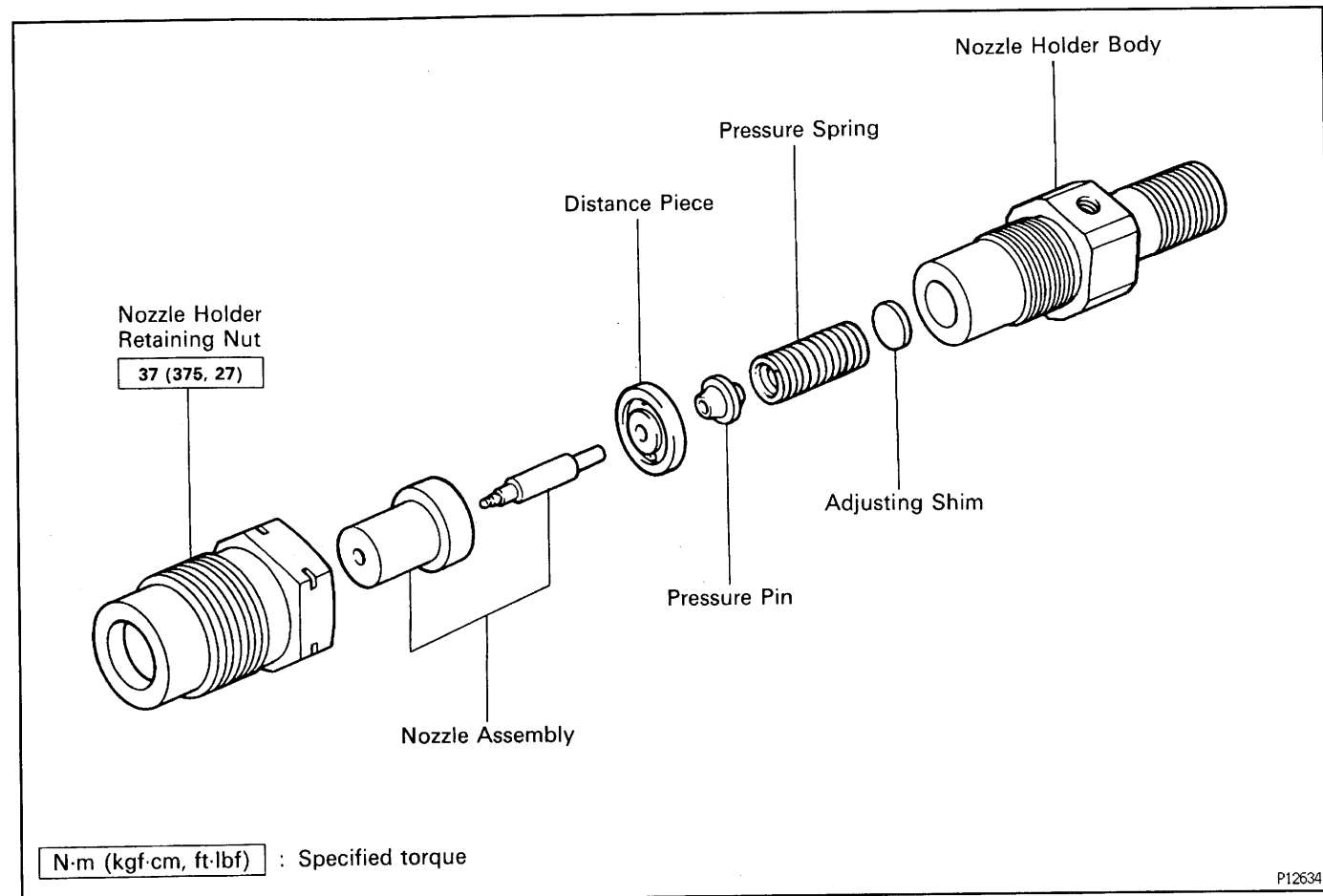

INJECTION NOZZLE DISASSEMBLY

EG340-01

DISASSEMBLE INJECTION NOZZLES

- Using SST, remove the nozzle holder retaining nut. SST 09268-64010 (09268-64020)
NOTICE: When disassembling the nozzle, be careful not to drop the inner parts.
- Remove the pressure spring, shim, pressure pin, distance piece and the nozzle assembly.

INJECTION NOZZLES CLEANING AND INSPECTION

EG341-01

1. NOZZLE CLEANING

- To wash the nozzles, use a wooden stick and brass brush. Wash them in clean diesel fuel.
HINT: Do not touch the nozzle mating surfaces with your fingers.

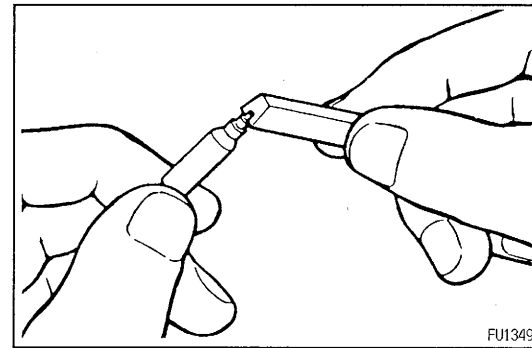
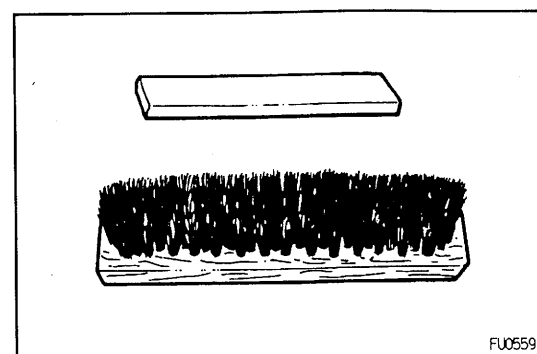
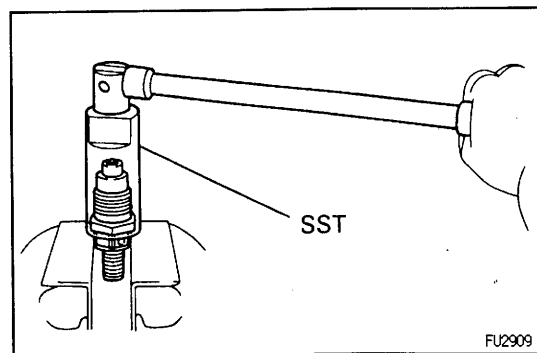

- Using a wooden stick, remove the carbon adhering to the nozzle needle tip.

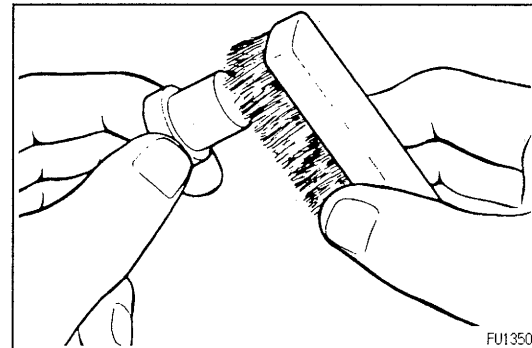

- Using a brass brush, remove the carbon from the exterior of the nozzle body (except lapped surface).

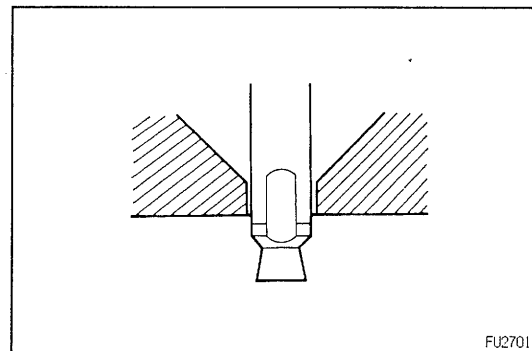

- Check the seat of the nozzle body for burns or corrosion.
- Check the nozzle needle tip for damage or corrosion. If any of these conditions are present, replace the nozzle assembly.

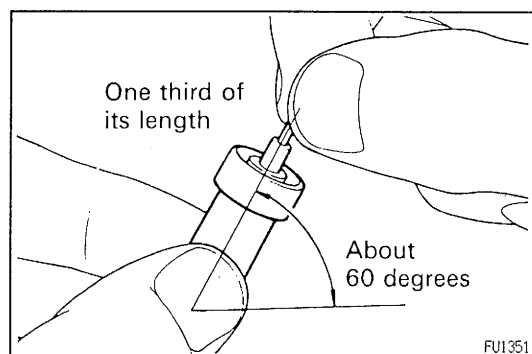

2. INSPECT NOZZLE ASSEMBLY

- Wash the nozzle in clean diesel fuel.
HINT: Do not touch the nozzle mating surfaces with your fingers.
- Tilt the nozzle body about 60 degrees and pull the needle out about one third of its length.

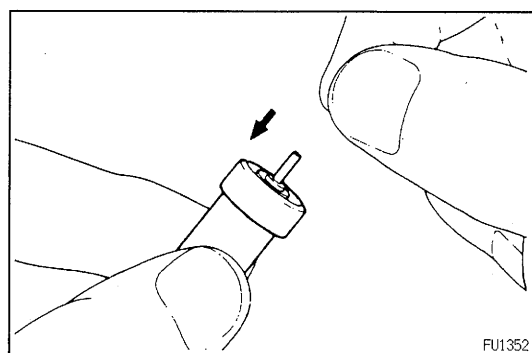

- When released, the needle should stick down into the body vent smoothly by its own weight.
- Repeat this test, rotating the needle slightly each time. If the needle does not sink freely, replace the nozzle assembly.

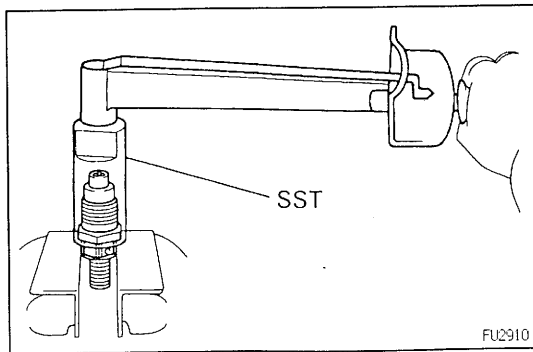

INJECTION NOZZLES ASSEMBLY

(See Components for Disassembly and Assembly)

1. ASSEMBLE INJECTION NOZZLE HOLDERS

- Assemble the nozzle holder retaining nut, the nozzle assembly, distance piece, pressure pin, pressure spring, adjusting shim and nozzle holder body, and finger tighten the retaining nut.
- Using SST, tighten the retaining nut.
SST 09268-64010 (09268-64020)
Torque: 37 N·m (375 kgf·cm, 27 ft·lbf)

NOTICE: Over torquing could cause nozzle deformation and needle adhesion or other defects.

- PERFORM PRESSURE AND SPRAY PATTERN TEST**
(See pages EG-154, 155)

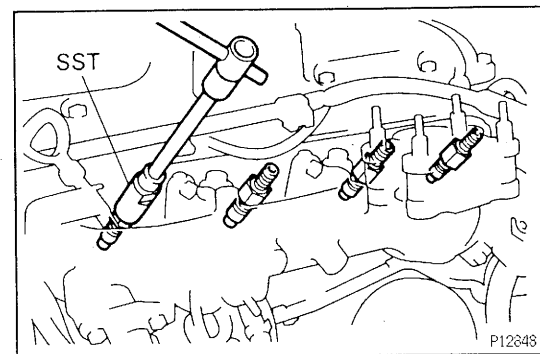

INJECTION NOZZLES INSTALLATION

(See Components for Removal and Installation)

1. INSTALL INJECTION NOZZLES

- Place the 4 nozzle seats and new gaskets into the injection nozzle holes of the cylinder head.
- Using SST, install the injection nozzles.
SST 09268-64010 (09268-64020)
Torque: 64 N·m (650 kgf·cm, 47 ft·lbf)

NOTICE:

- Over torquing could cause nozzle deformation and needle adhesion or other defects.
- When installing the injection nozzle, never torque the nozzle holder body. Torque the retaining nut section.

2. INSTALL NOZZLE LEAKAGE PIPE

- Install 4 new gaskets and the leakage pipe with the nuts.
Torque: 30 N·m (300 kgf·cm, 22 ft·lbf)
- Connect the fuel hose to the return pipe.

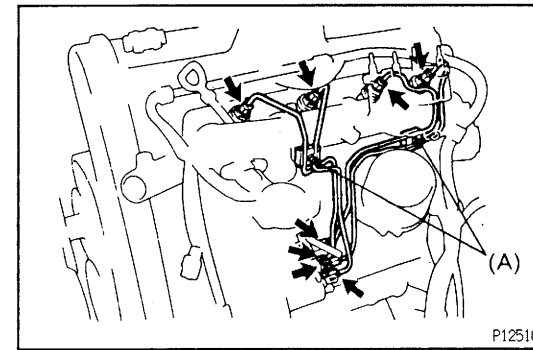
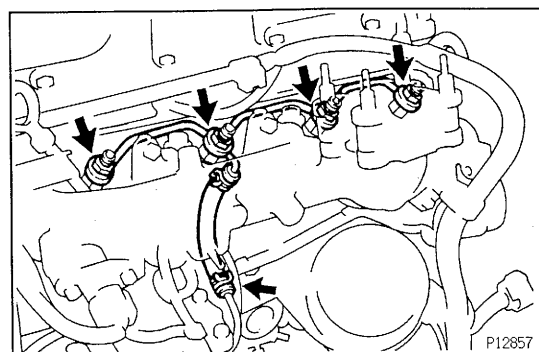

3. INSTALL INJECTION PIPES

- Temporarily install the 4 injection pipes and 2 clamps (A).

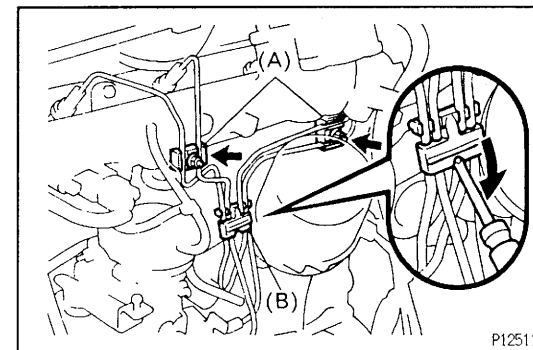

- Install the 2 nuts holding the clamps (A) to the intake manifold.
Torque: 6 N·m (65 kgf·cm, 56 in·lbf)
- Using a screwdriver, attach the clamp (B).
- Tighten the 8 union nuts.
Torque: 15 N·m (150 kgf·cm, 11 ft·lbf)

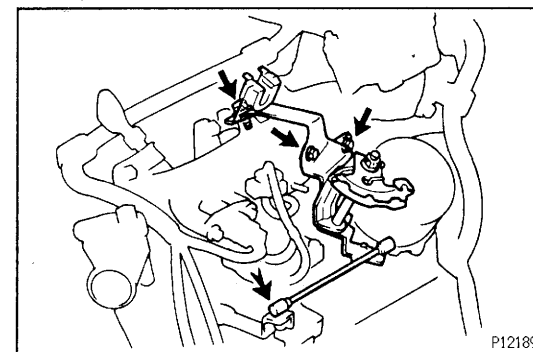

4. INSTALL ACCELERATOR CABLE BRACKET AND LINK

- Install the accelerator cable bracket and link with the 3 bolts.
- Connect the accelerator link to the injection pump.

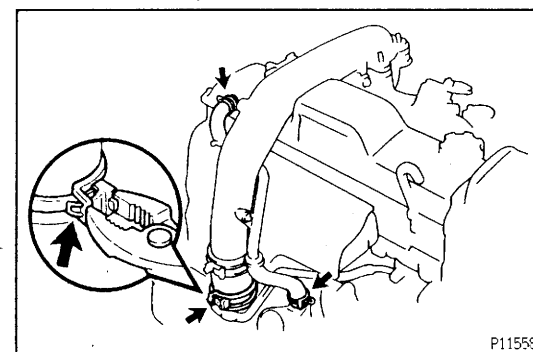

5. INSTALL INTAKE PIPE

- Place a new gasket on the intake manifold.
- Connect the air hose and install the intake pipe.
- Press the clamp lock together with pliers and press down the tip of the lock plate. Carefully let the lock spread apart.
Take care not to let the pliers slip.
- Connect the 2 PCV hoses.

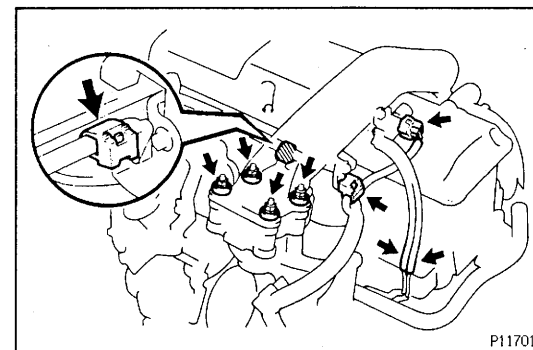

- Install the 4 seal washers and nuts.
Torque: 12 N·m (120 kgf·cm, 9 ft·lbf)
 - Connect the 2 wire harness clamps.
 - Connect the VSV connector and 2 vacuum hoses.
- ### 6. START ENGINE AND CHECK FOR FUEL LEAKAGE

INJECTION PUMP COMPONENTS FOR REMOVAL AND INSTALLATION

EG344-01

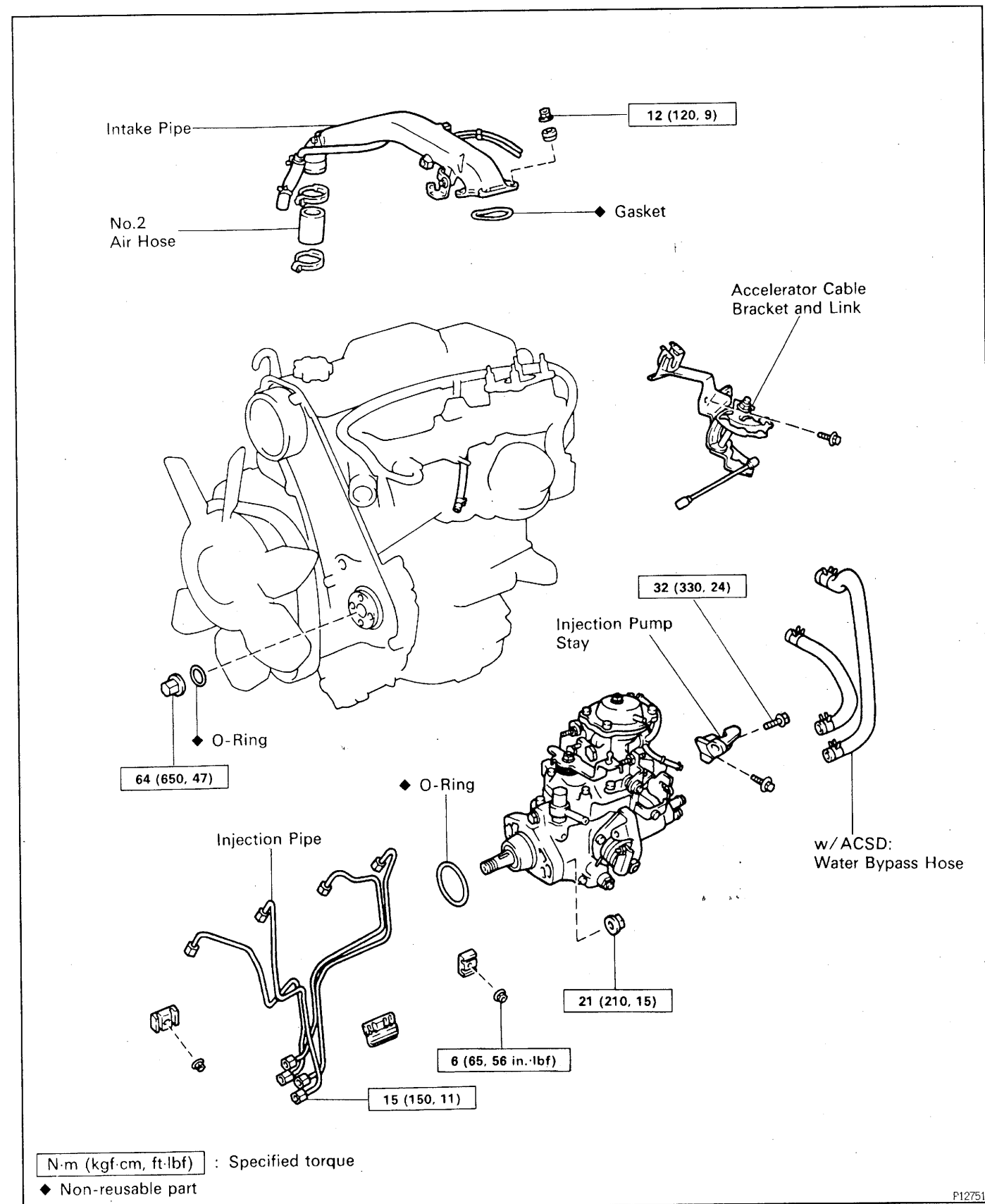

EG345-01

INJECTION PUMP REMOVAL

(See Components for Removal and Installation)

1. w/ ACSD:
DRAIN ENGINE COOLANT
(See page EG-233)

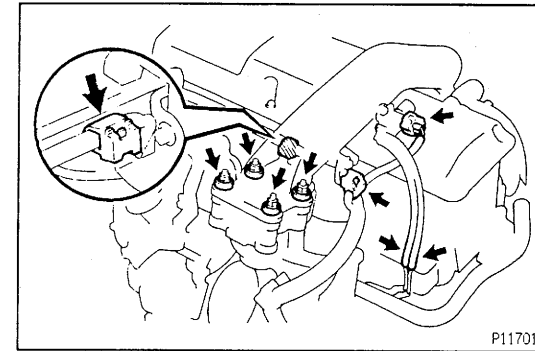

2. REMOVE INTAKE PIPE

- (a) Disconnect the VSV connector and 2 vacuum hoses.
- (b) Disconnect the 2 wire harness clamps.
- (c) Remove the 4 nuts and seal washers.

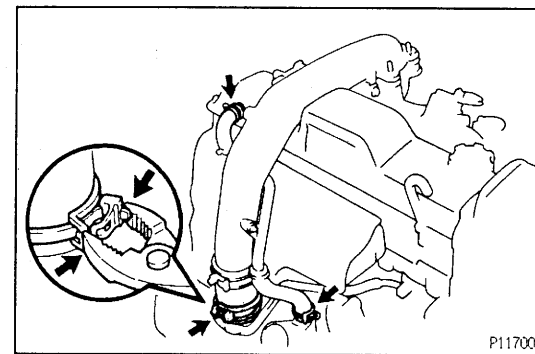

- (d) Disconnect the 2 PCV hoses.
- (e) Use pliers to pinch the ends of the clamp together until the lock plate engages the catch. Make sure the lock plate and catch are engaged securely.
- (f) Remove the intake pipe and gasket.

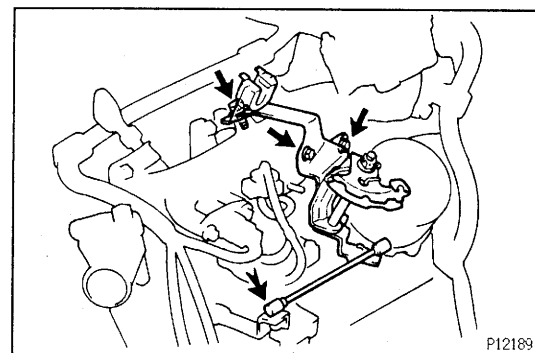

3. REMOVE ACCELERATOR CABLE BRACKET AND LINK

- (a) Disconnect the accelerator link from the injection pump.
- (b) Remove the 3 bolts and accelerator cable bracket and link.

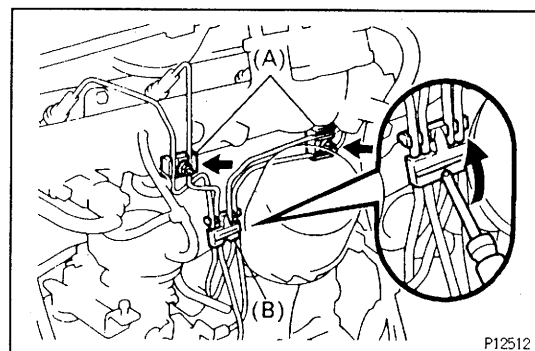

4. REMOVE INJECTION PIPES

- (a) Remove the 2 nuts holding the clamps (A) to the intake manifold.
- (b) Using a screwdriver, pry out the clamp (B).

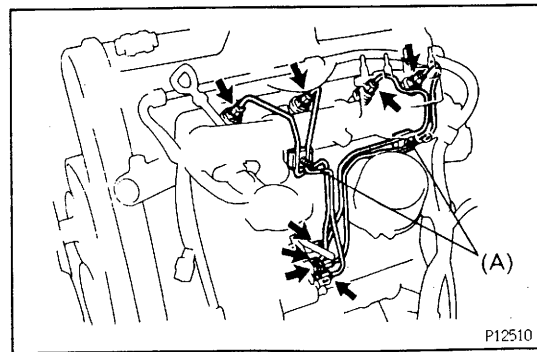

- (c) Loosen the 8 union nuts of the injection pipes.
 (d) Remove the 4 injection pipes and 2 clamps (A).

5. w/ A/C:
DISCONNECT A/C IDLE-UP VACUUM HOSE
 6. **REMOVE TIMING BELT**
 (See steps 1 to 6 on pages EG-32, 33)
 7. **REMOVE NO.2 CAMSHAFT TIMING PULLEY**
 (See step 7 on page EG-33)

8. **REMOVE INJECTION PUMP**

- (a) w/ ACSD:
 Disconnect the 2 water bypass hoses from the thermo wax.

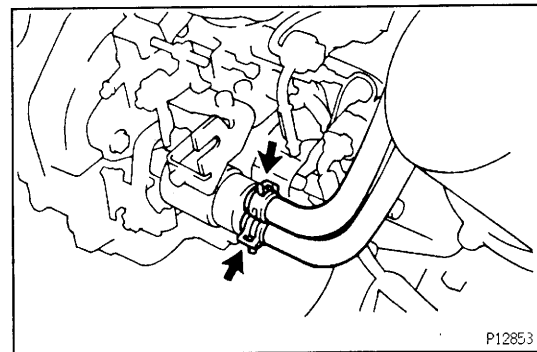

- (b) Disconnect the injection pump connector.

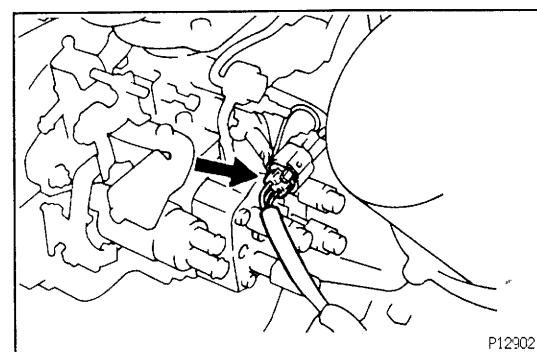

- (c) Disconnect the following hoses:
 (1) Fuel hose
 (2) PCS vacuum hose
 (3) Boost compensater hose
 (4) w/ BACS:
 BACS vacuum hose

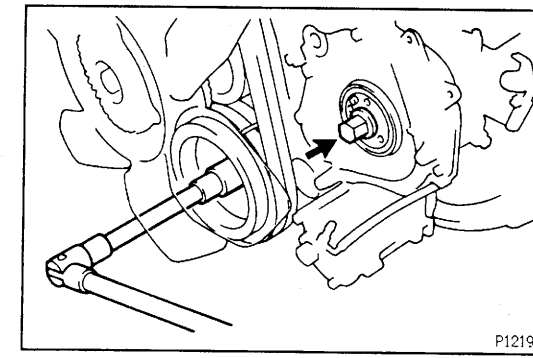
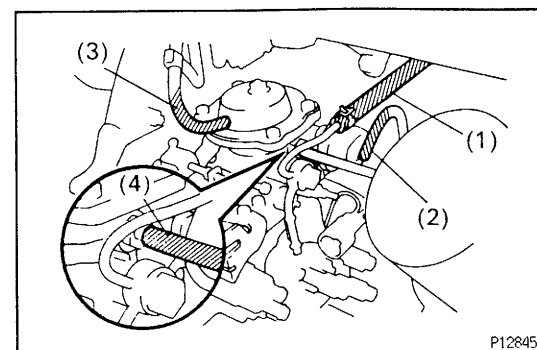

- (d) Hold the crankshaft pulley, and remove the injection pump drive gear set nut.

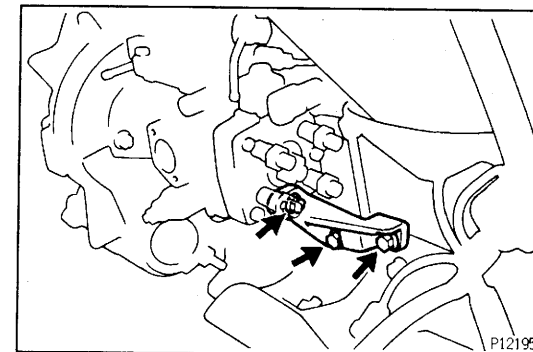

- (e) Remove the 3 bolts and injection pump stay.

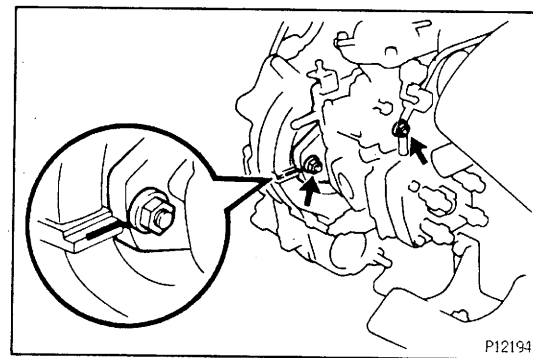

- (f) Before removing the injection pump, check if the period lines are aligned.
 If not, place new matchmarks for reinstallation.
 (g) Remove the 2 nuts holding the injection pump to the timing gear case.

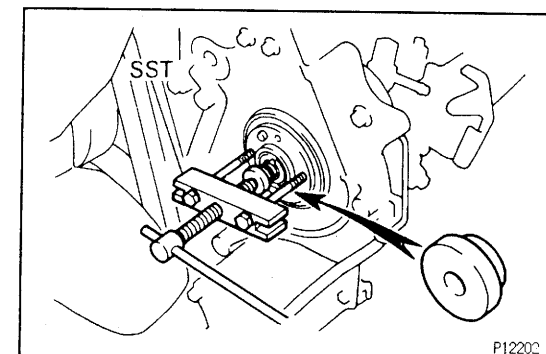

- (h) Using SST, remove the injection pump.
 SST 09213-60017 (09213-00020, 09213-00030, 09213-00060) and 09950-20017

NOTICE:

- Tighten the 2 bolts more than 8 mm (0.31 in.).
 - Set SST so that it is balanced.
 - Do not hold or carry the injection pump by the adjusting lever.
 - Do not put the injection pump at an angle more than 45° from the horizontal.
- (i) Remove the O-ring from the injection pump.

INJECTION PUMP DISASSEMBLY

(See Components for Disassembly and Assembly)

1. **MOUNT PUMP ASSEMBLY TO SST (STAND)**
SST 09241-76022 and 09245-54010
2. **REMOVE SET KEY OF DRIVE PULLEY FROM DRIVE SHAFT**
3. **w/ A/C:**
REMOVE IDLE-UP ACTUATOR

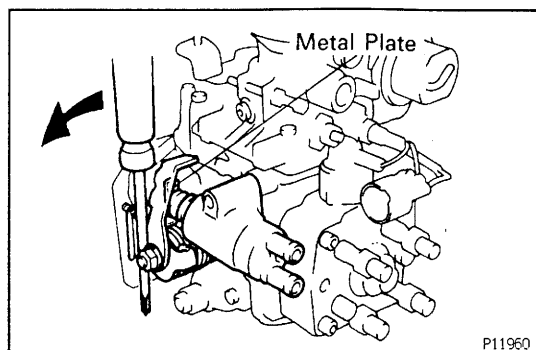
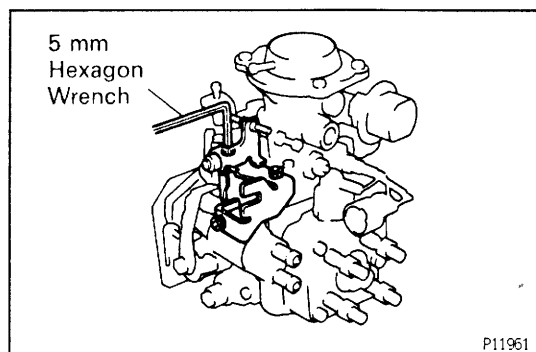
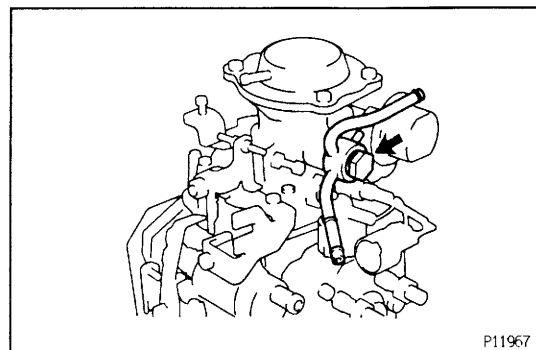
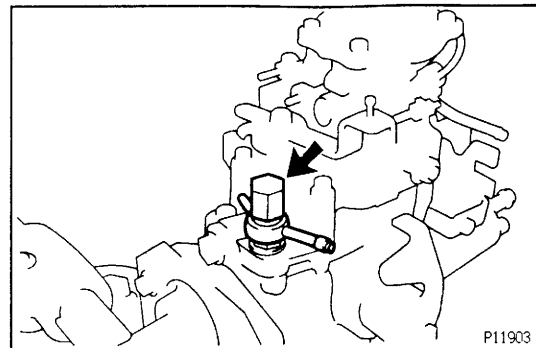
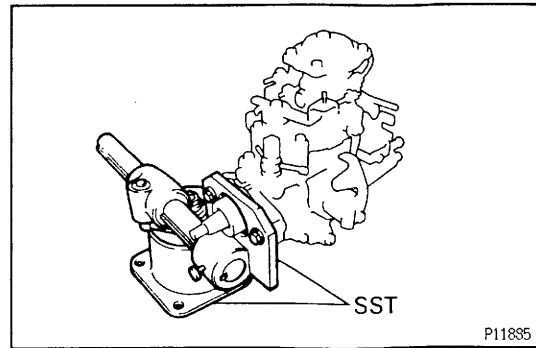

4. **REMOVE FUEL PIPES**
 - (a) Remove the cap nut, fuel inlet pipe and 2 gaskets.
 - (b) Remove the union bolt, fuel outlet pipe and 2 gaskets.

5. **w/ ACSD:**
REMOVE IDLE-UP LEVER
Using a 5 mm hexagon wrench, remove the 3 bolts and idle-up lever.

6. **w/ ACSD:**
REMOVE THERMO WAX
 - (a) Using a screwdriver, turn the cold starting lever counterclockwise approx. 20°.
 - (b) Put a metal plate (thickness of 8.5 – 10 mm (0.33 – 0.39 in.)) between the cold starting lever and thermo wax plunger.

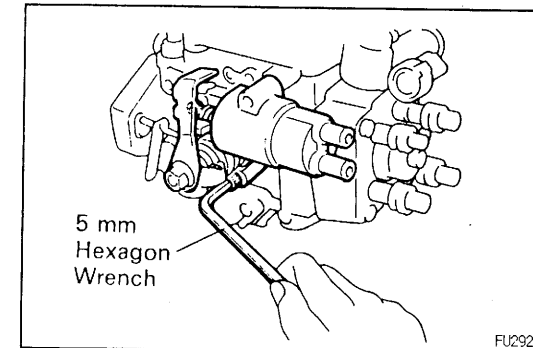

- (c) Using a 5 mm hexagon wrench, remove the 2 bolts, thermo wax and O-ring.

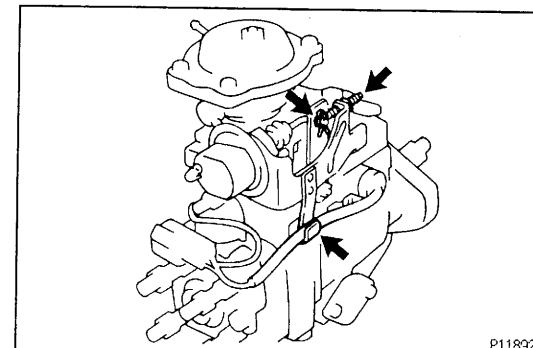

7. **REMOVE PCS ACTUATOR**
 - (a) Remove the PCS adjusting screw.
 - (b) Remove the clip.
 - (c) Disconnect the wire harness.

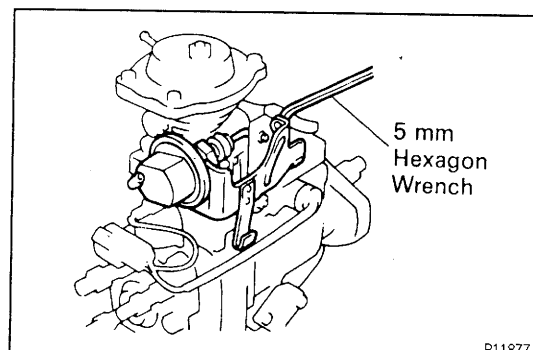

- (d) Using a 5 mm hexagon wrench, remove the 2 bolts and PCS actuator assembly.

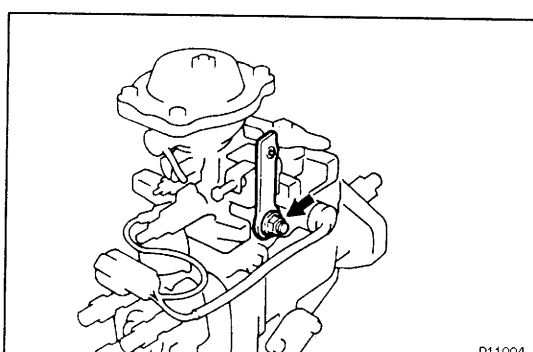

8. **REMOVE NO.1 PCS LEVER**
Remove the nut and No.1 PCS lever.

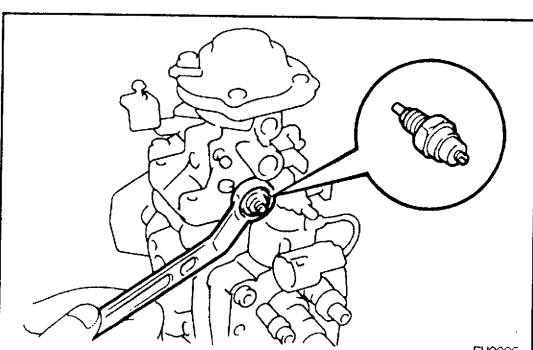

9. **REMOVE DASH POT**
Remove the dash pot and gasket.

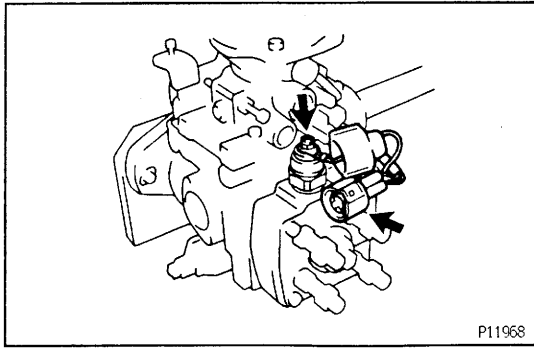
**10. REMOVE FUEL CUT SOLENOID**

- (a) Disconnect the lead wire connector from the bracket.
- (b) Disconnect the dust cover from the fuel cut solenoid.
- (c) Remove the nut, lead wire and dust cover.

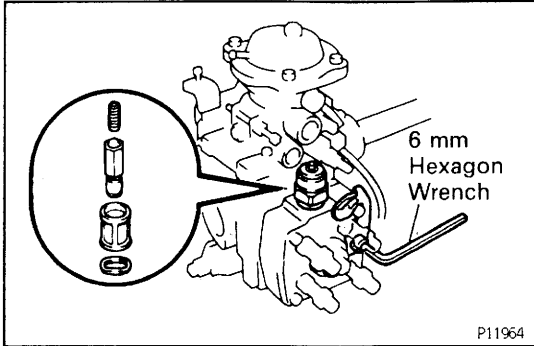

- (d) Using a 6 mm hexagon wrench, remove the bolt and connector bracket.
- (e) Remove the fuel cut solenoid, O-ring, spring, valve, strainer and wave washer.

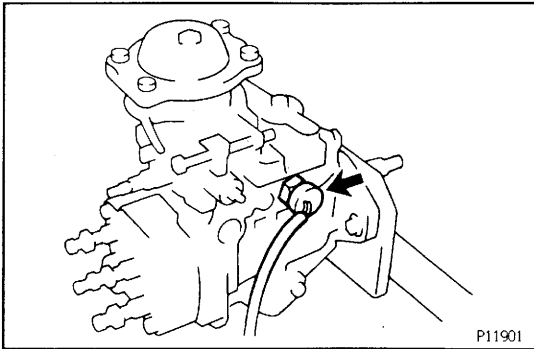
**11. REMOVE PICKUP SENSOR**

- (a) Remove the pickup sensor and O-ring.
- (b) Disconnect the sensor lead wires from the connector.

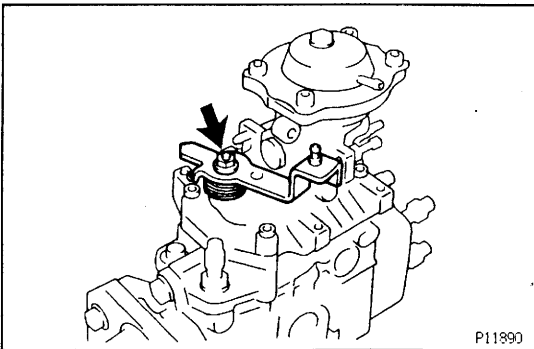
**12. REMOVE ADJUSTING LEVER**

Remove the nut, adjusting lever, return spring and return spring guide.

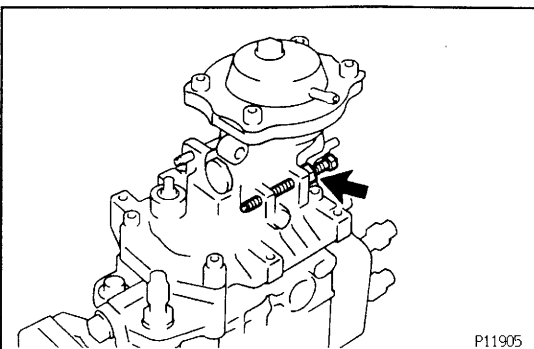
**13. REMOVE GOVERNOR COVER**

- (a) Remove the idle speed adjusting screw.

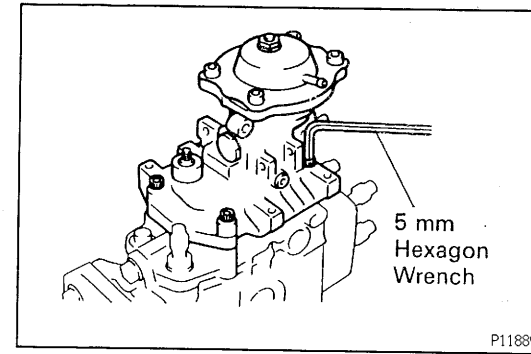

- (b) Using a 5 mm hexagon wrench, remove the 4 bolts.

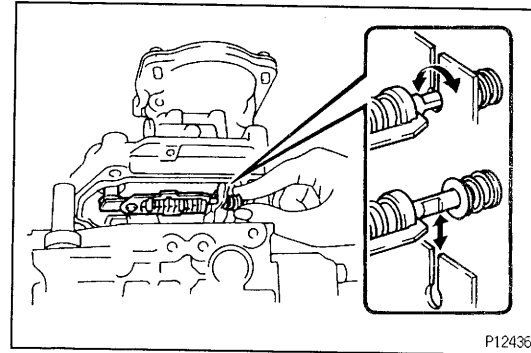

- (c) Disconnect the adjusting shaft assembly from the governor link and remove the governor cover and gasket.

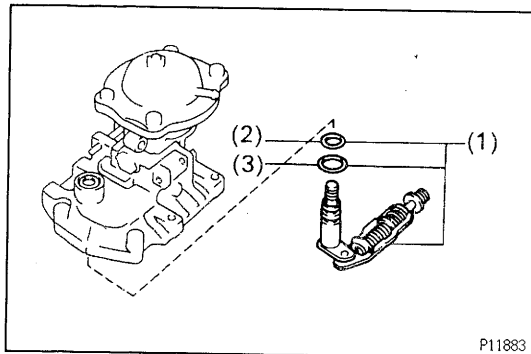
**14. REMOVE GOVERNOR ADJUSTING LEVER SHAFT FROM GOVERNOR COVER**

Remove the following parts from the governor cover.

- (1) Adjusting lever shaft, O-ring and washer assembly
- (2) O-ring
- (3) Washer

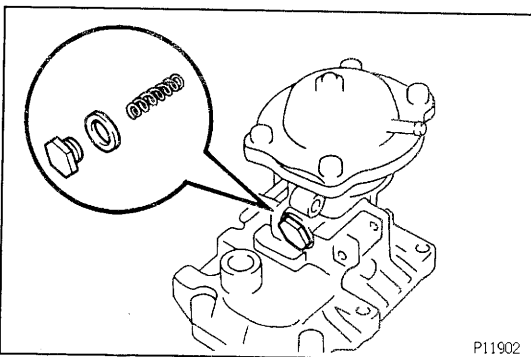
**15. DISASSEMBLE BOOST COMPENSATOR****A. Remove lever control spring**

Remove the bolt, gasket and lever control spring.

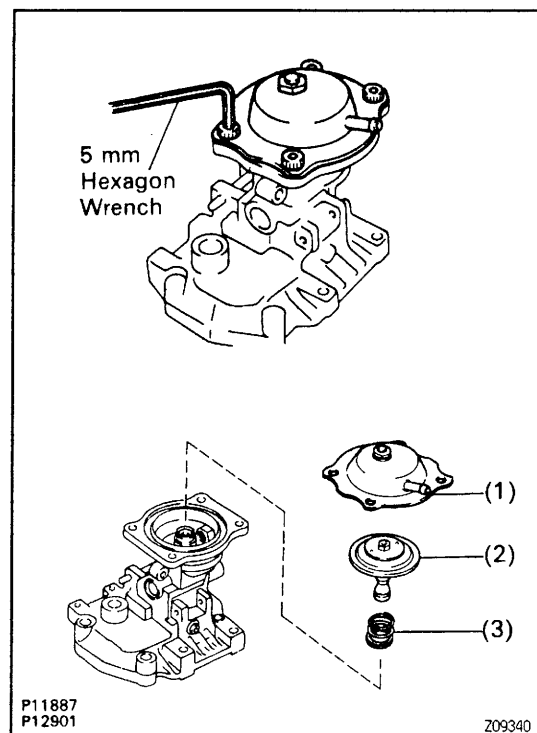
**B. Remove boost compensator diaphragm**

- (a) Using a 5 mm hexagon wrench, remove the 4 bolts and following parts:
- (1) Diaphragm cover
 - (2) Diaphragm assembly
 - (3) Spring

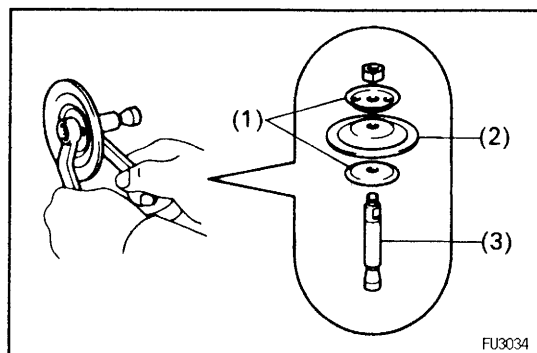

- (b) Remove the nut, and disassemble the following parts:

- (1) 2 spring seats
- (2) Diaphragm
- (3) Push rod

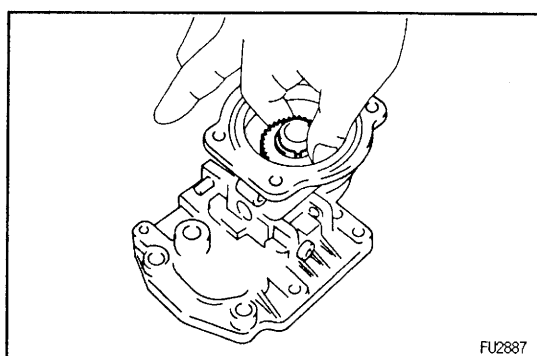
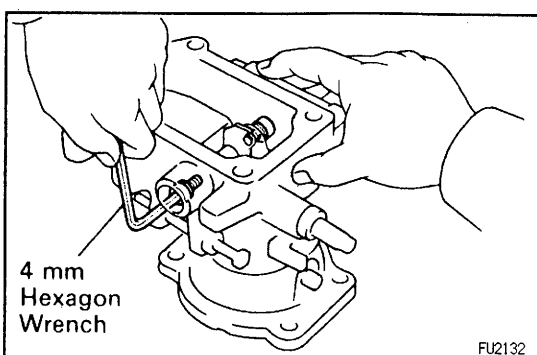
**C. Remove guide bushing****D. Remove control lever**

- (a) Using a 4 mm hexagon wrench, remove the 2 bolts and gaskets.

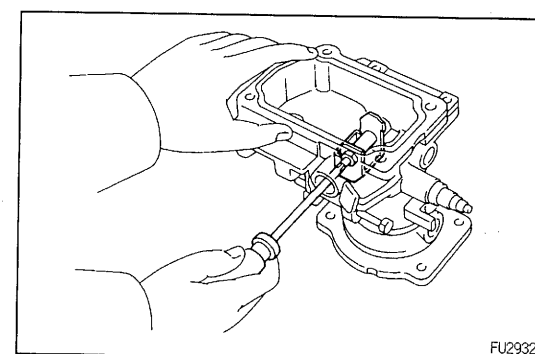

- (b) Using a small screwdriver, push out the support pin and remove the control lever.

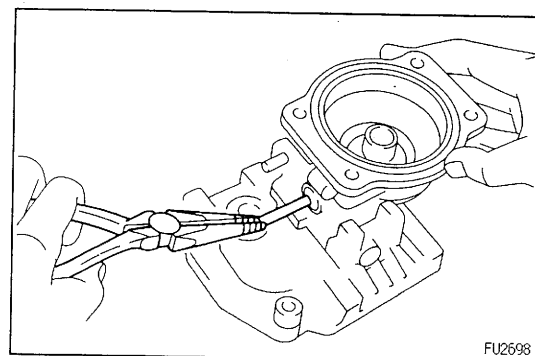

- (c) Using needle nose pliers, remove the connecting pin. **NOTICE:** Be careful not to damage the connecting pin. Tape the tip of the pliers.

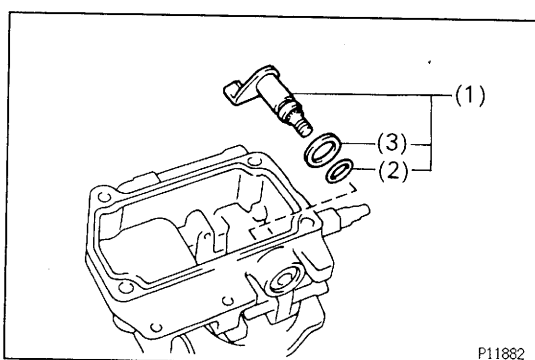
**E. Remove No.2 PCS lever**

Remove the following parts from the governor cover.

- (1) No.2 PCS lever, O-ring and washer assembly
- (2) O-ring
- (3) Washer

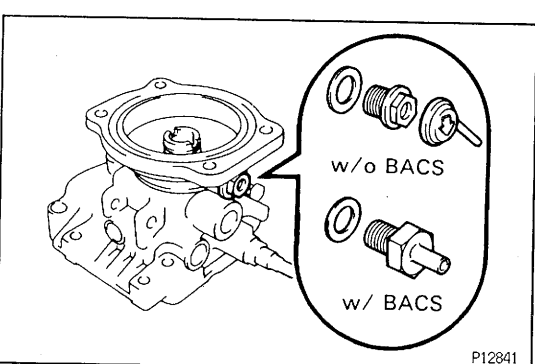
**F. Remove overflow screw**

- (a) w/o BACS:
Remove the rubber cap.
- (b) Remove the overflow screw and gasket.

16. CHECK FLYWEIGHT HOLDER THRUST CLEARANCE (See step 19 on page EG-189)

Thrust clearance:

0.15 – 0.35 mm (0.0059 – 0.0138 in.)

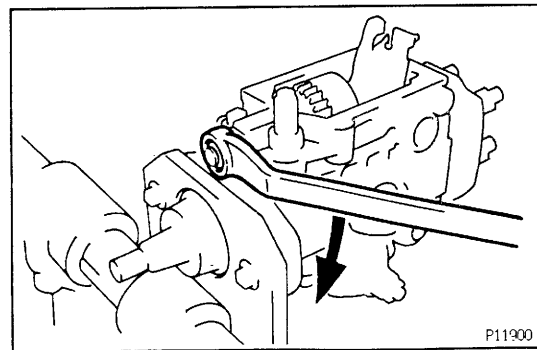

17. REMOVE GOVERNOR SHAFT AND FLYWEIGHT HOLDER

- (a) Remove the governor shaft lock nut by turning it clockwise.

NOTICE: The governor shaft and lock nut have LH threads.

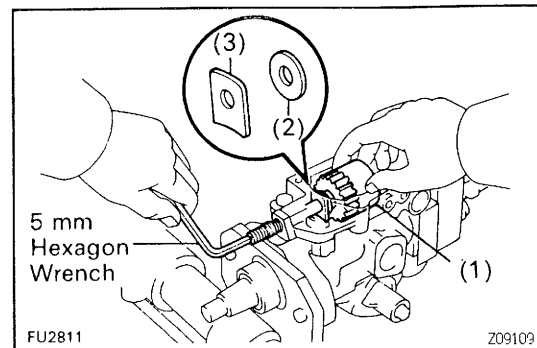

- (b) Using a 5 mm hexagon wrench, remove the governor shaft clockwise, and remove the following parts:

- (1) Flyweight holder assembly
- (2) No.1 flyweight washer
- (3) Governor gear adjusting washer

HINT: Be careful not to drop the 2 washers into the pump housing.

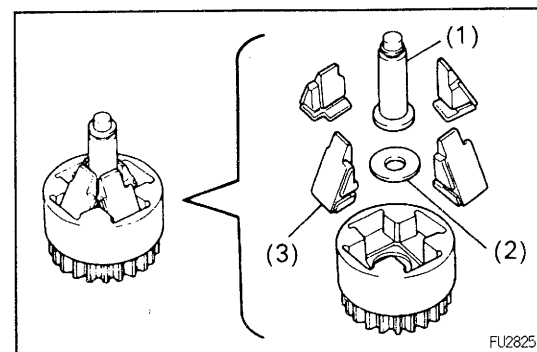

- (c) Remove the following parts from the flyweight holder.

- (1) Governor sleeve
- (2) No.2 flyweight washer
- (3) 4 flyweights

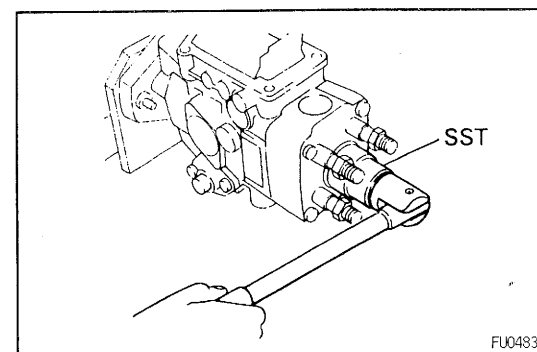

18. REMOVE DISTRIBUTIVE HEAD PLUG

Using SST, remove the distributive head plug.
SST 09260-54012 (09262-54010)

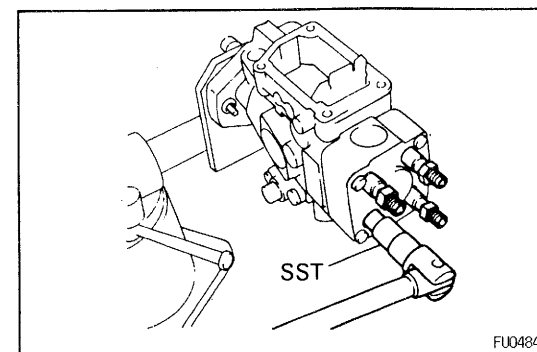

19. REMOVE DELIVERY VALVE HOLDERS

- (a) Using SST, remove the 4 delivery valve holders and springs.

SST 09260-54012 (09269-54020)

- (b) Remove the 4 delivery valves and gaskets.

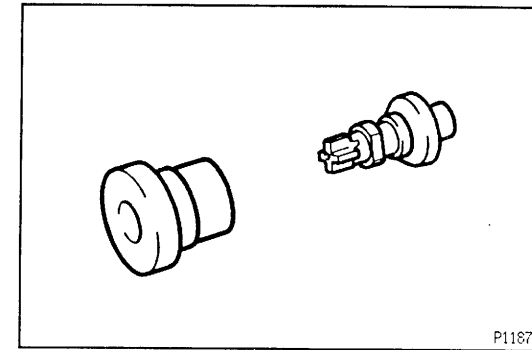

NOTICE: Do not touch the sliding surfaces of the delivery valve with your hand.

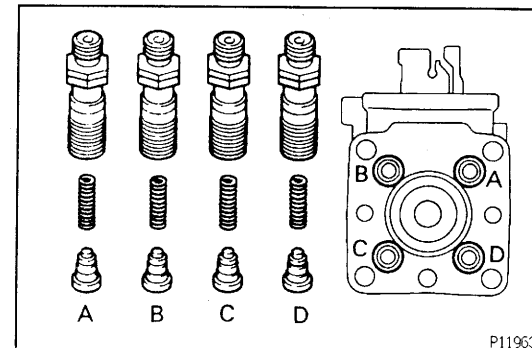

HINT: Arrange the delivery valves, springs, and holders in order.

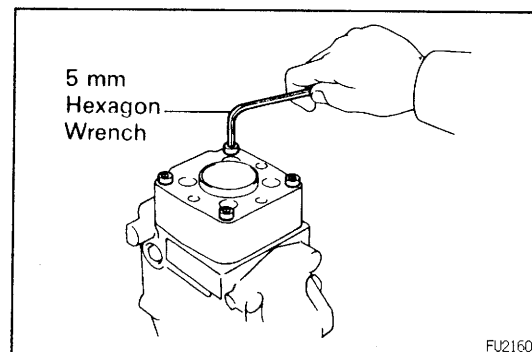

20. REMOVE DISTRIBUTIVE HEAD

- (a) Using a 5 mm hexagon wrench, remove the 4 bolts.

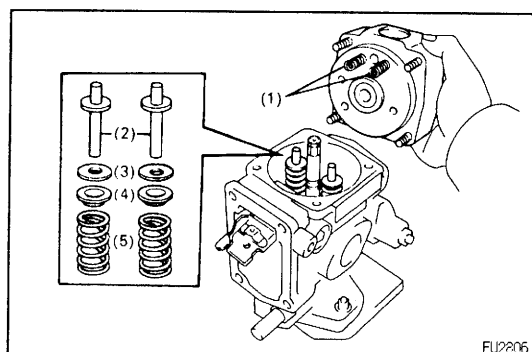

- (b) Remove the distributive head and following parts:

- (1) 2 lever support springs
- (2) 2 plunger spring guides
- (3) 2 plunger spring shims
- (4) 2 upper spring seats
- (5) 2 plunger springs

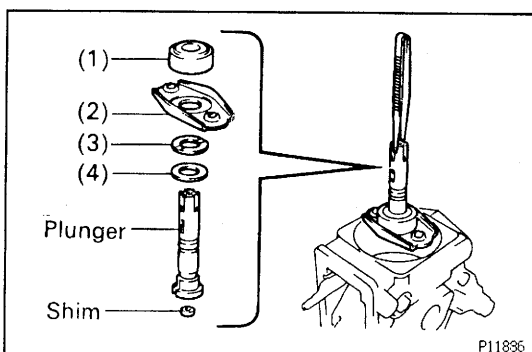

21. REMOVE PUMP PLUNGER

Using SST, remove the pump plunger and plunger adjusting shim together with the following parts:

- (1) Spill ring
 - (2) Lower spring seat
 - (3) Upper plunger plate
 - (4) Lower plunger plate
- SST 09260-54012 (09269-54030)

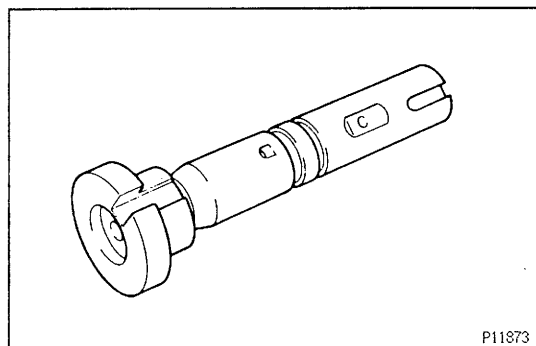

NOTICE: Do not touch the sliding surfaces of the pump plunger with your hand.

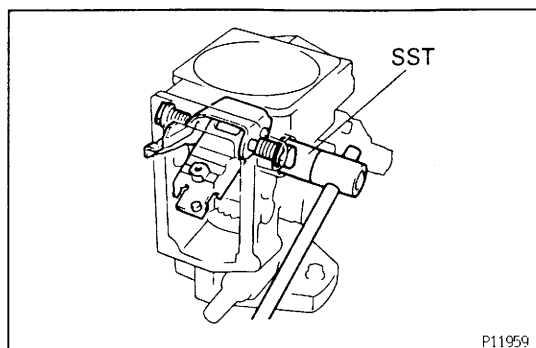

22. REMOVE GOVERNOR LINK

Using SST, remove the 2 support bolts, gaskets and governor link.
SST 09260-54012 (09269-54040)

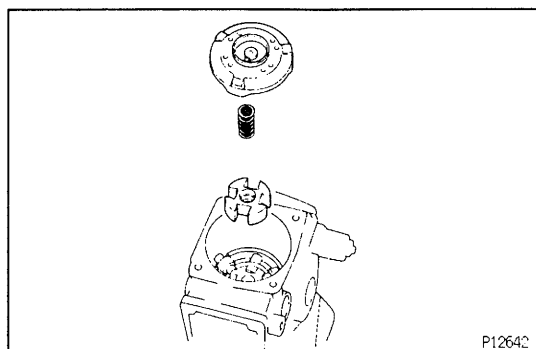

23. REMOVE FACE CAMPLATE AND COUPLING

Remove the face camplate, spring and coupling.

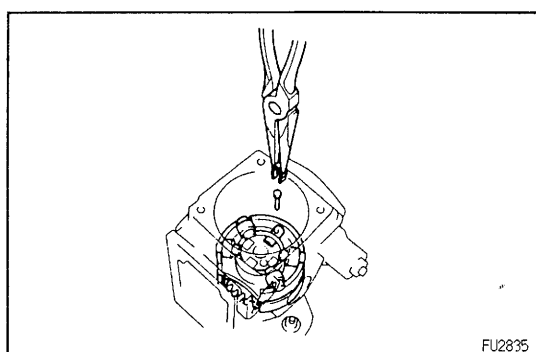

24. REMOVE ROLLER RING AND DRIVE SHAFT

(a) Remove the timer clip and stopper pin.

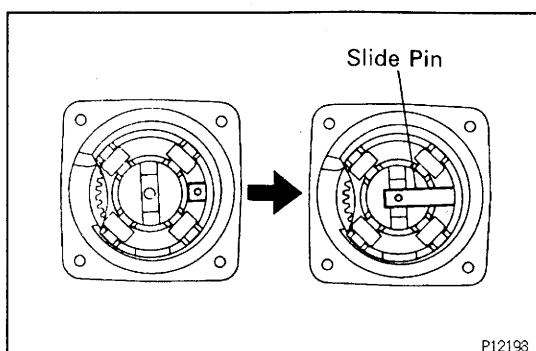

(b) Push the slide pin toward inside.

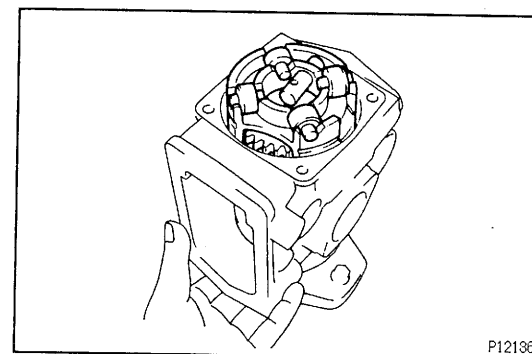

(c) Push the drive shaft, and remove the roller ring, 4 rollers and shims assembly.

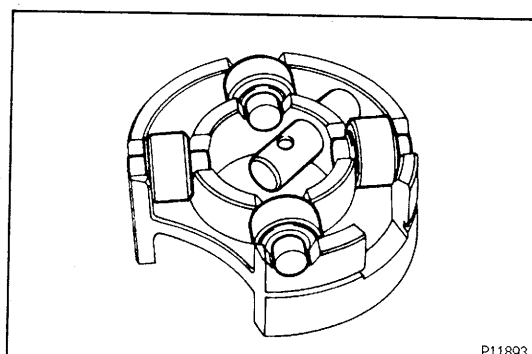

NOTICE:

- Be careful not to drop the rollers.
- Do not alter the position or assembly of the rollers.

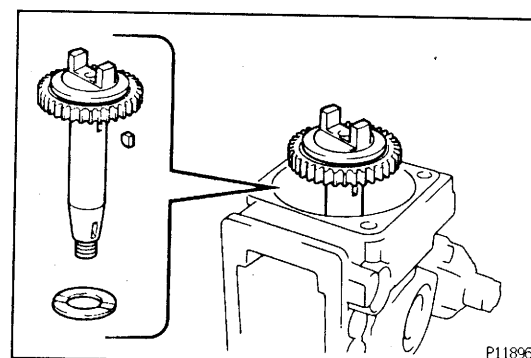

(d) Remove the drive shaft, governor drive gear, 2 joint rubbers assembly, set key and drive shaft washer.

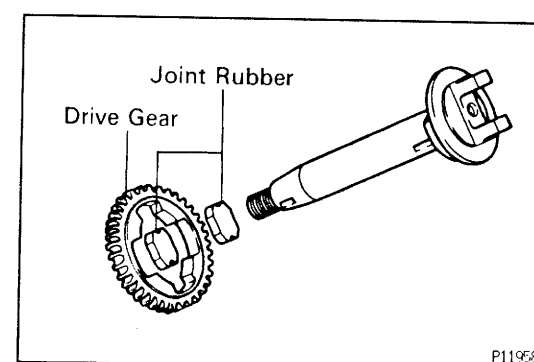

(e) Remove the drive gear and 2 joint rubbers from the drive shaft.

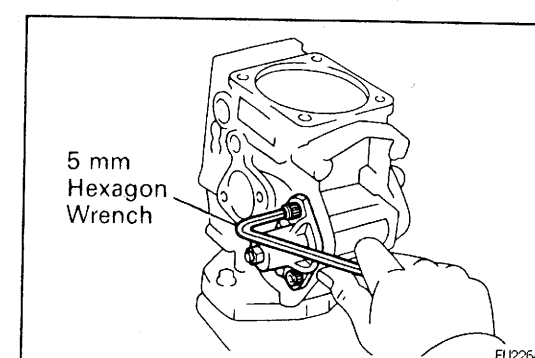

25. REMOVE TIMER

(a) Using a 5 mm hexagon wrench, remove the 4 bolts.

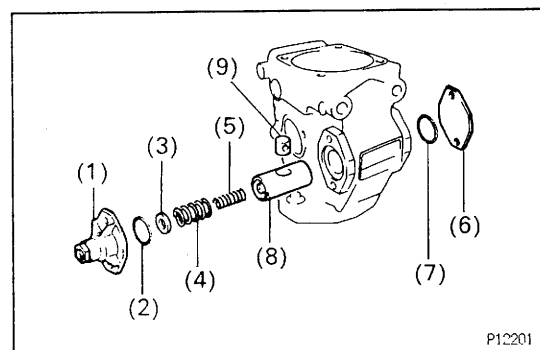

- (b) Remove the following parts:
- (1) LH timer cover, timer adjusting screw and nut assembly
 - (2) O—ring
 - (3) Shim
 - (4) Outer spring
 - (5) Inner spring
 - (6) RH timer cover
 - (7) O—ring
 - (8) Piston
 - (9) Sub—piston

- (c) Remove the nut from the LH timer cover.
 (d) Using a 5 mm hexagon wrench, remove the timer adjusting screw.
 (e) Remove the O—ring from the timer adjusting ring.

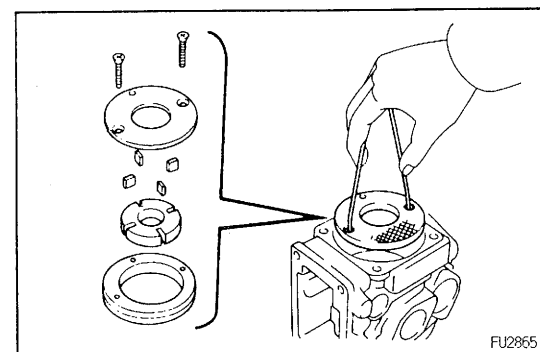
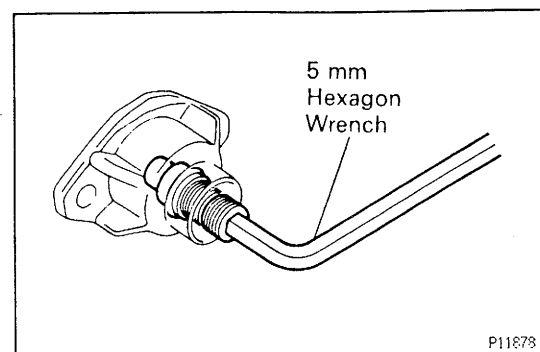

26. REMOVE FUEL FEED PUMP

- (a) Remove the 2 screws.
 (b) Using a piece of wire, remove the feed pump cover.
 (c) Remove the feed pump rotor, 4 blades and liner.

NOTICE:

- Be careful not to interchange the blade positions.
- Be careful not to damage the pump body.

27. REMOVE REGULATOR VALVE

Using SST, remove the regulator valve and 2 O—rings.
 SST 09260—54012 (09262—54020)

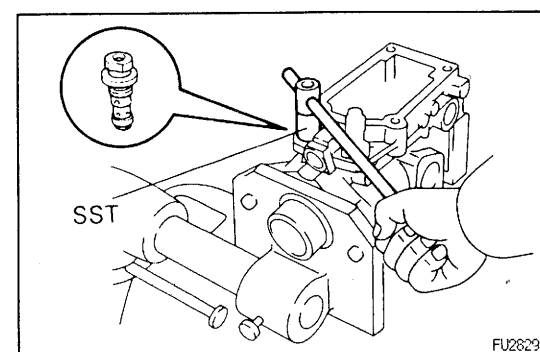

28. REMOVE FUEL INLET HOLLOW SCREW

Remove the hollow screw and gasket.

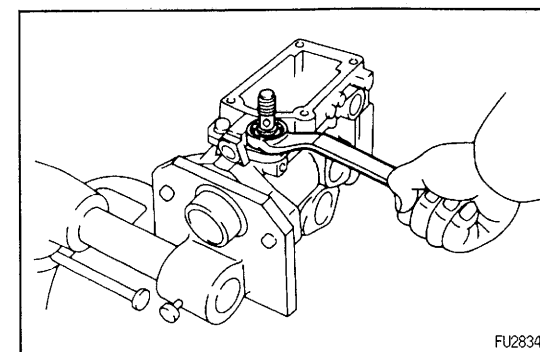

INJECTION PUMP COMPONENTS INSPECTION

NOTICE: Do not touch the sliding surfaces of the pump plunger and delivery valves.

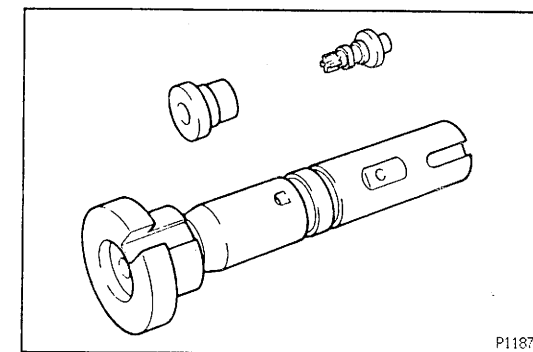

1. INSPECT DELIVERY VALVES

- (a) Pull up the valve and close the hole at the valve seat bottom end with your thumb.
 When the valve is released, it should sink down quickly and stop at the position where the relief ring closes the valve seat hole.

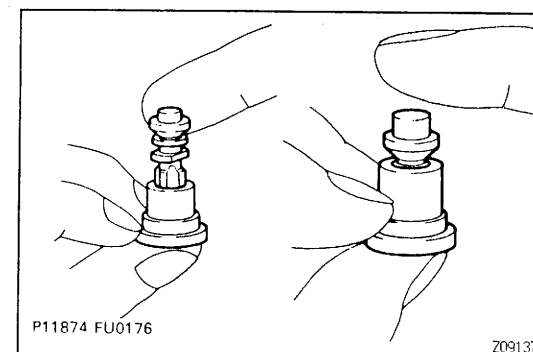

- (b) Close the hole at the valve seat bottom end with your thumb.
 Insert the valve into the valve seat and press down with your finger. When your finger is released, the valve should rise back to its original position.

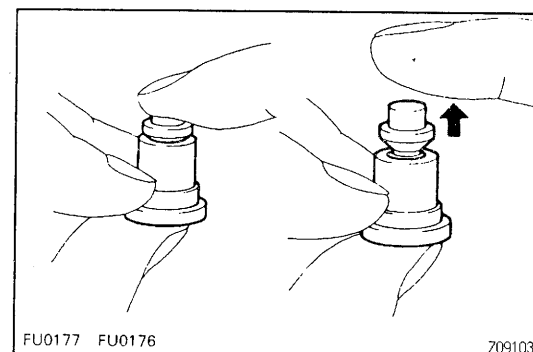

- (c) Remove your thumb from the valve seat hole.
 The valve should close completely by its own weight. If operation is not as specified, replace the valve as a set.
HINT: Before using a new valve set, wash off the rust prevention compound with light oil or gasoline. Then re—wash with diesel fuel and perform the above tests.

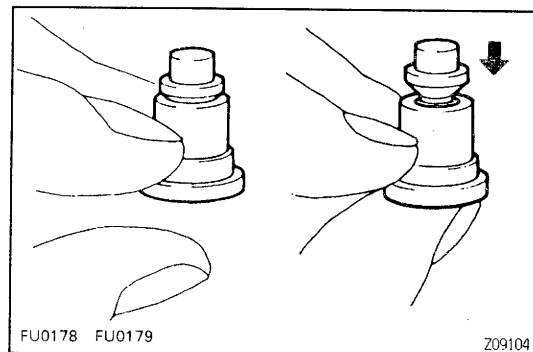

2. INSPECT PUMP PLUNGER, SPILL RING AND DISTRIBUTIVE HEAD

- (a) Tilt the spill ring (distributive head) slightly and pull out the plunger.
 (b) When released, the plunger should sink down smoothly into the spill ring (distributive head) by its own weight.
 (c) Rotate the plunger and repeat the test at various positions.

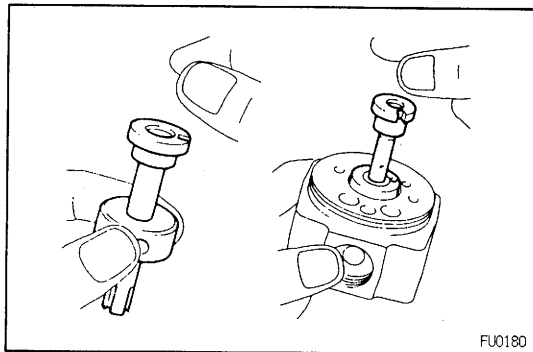

If the plunger sticks at any position, replace the parts as a set.

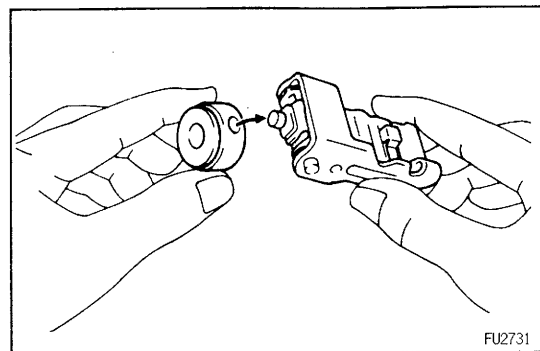

- (d) Insert the governor link ball pin into the spill ring and check that it moves smoothly without any play.

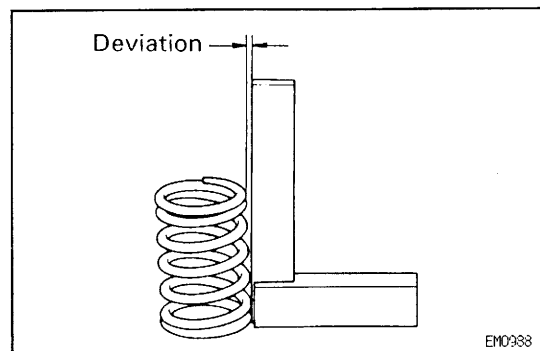

3. INSPECT PLUNGER SPRINGS FOR DEVIATION

Using a steel square, check the deviation of the plunger springs.

Maximum deviation:

2.0 mm (0.079 in.)

If deviation is greater than maximum, replace the springs.

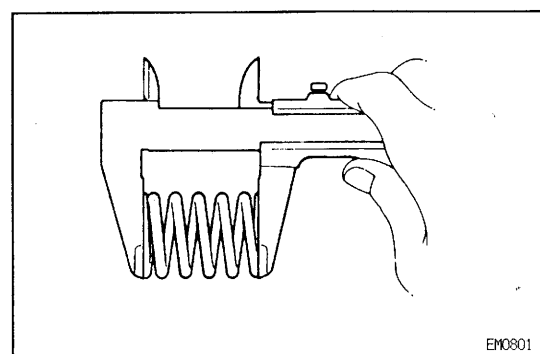

4. INSPECT SPRING LENGTH

Using vernier calipers, measure the free length of each spring.

Spring free length:

Delivery valve spring

24.4 mm (0.961 in.)

Plunger spring

30.0 mm (1.181 in.)

Coupling spring

15.5 mm (0.610 in.)

Boost compensator spring

w/o BACS 19.4 mm (0.764 in.)

w/ BACS 19.3 mm (0.760 in.)

If the free length is not as specified, replace the spring (s).

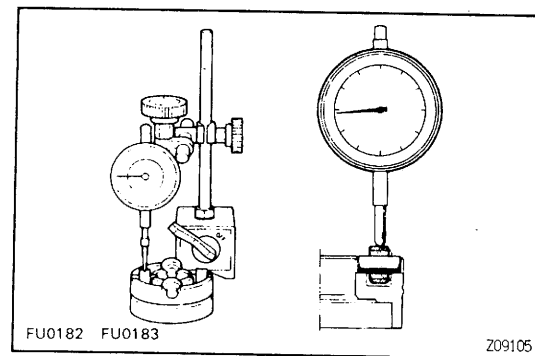

5. INSPECT ROLLER RING AND ROLLERS

Using a dial indicator, measure the roller height.

Maximum roller height variation:

0.02 mm (0.0008 in.)

If the variation is greater than specification, replace the roller ring and roller as a set.

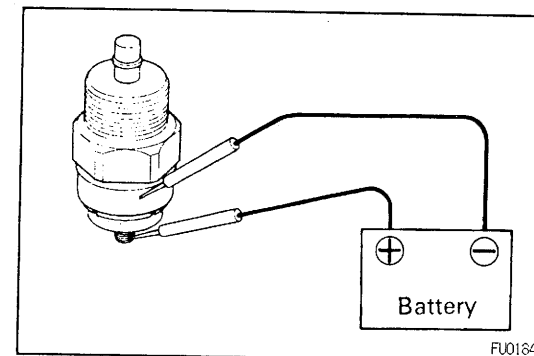

6. INSPECT FUEL CUT SOLENOID

- (a) Connect the solenoid valve body and terminal to the battery terminals.

- (b) You should feel the click from the solenoid valve when the battery power is connected and disconnected. If the solenoid valve is not operating properly, replace it.

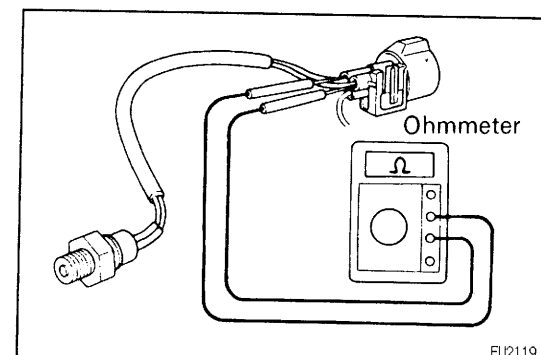

7. INSPECT PICKUP SENSOR

Using an ohmmeter, measure the resistance between the terminals.

Resistance: 650 – 970 Ω

If resistance is not as specified, replace the sensor.

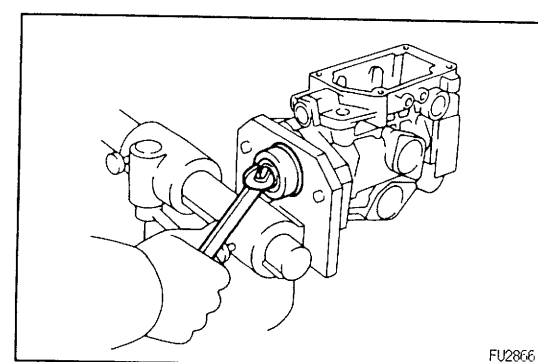

8. IF NECESSARY, REPLACE OIL SEAL

- (a) Using a wrench, pry out the oil seal.

NOTICE: Be careful not to damage to the pump body.

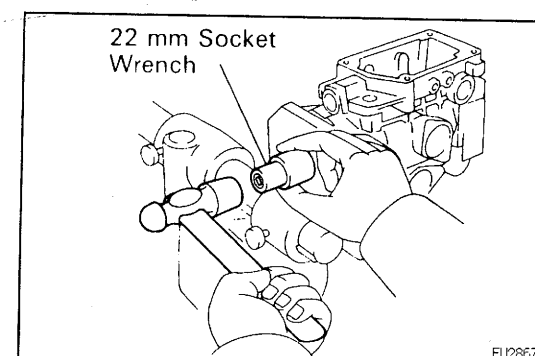

- (b) Apply MP grease to the lip of a new oil seal.
- (c) Using a 22 mm socket wrench, tap in the oil seal until its surface is flush with the pump housing.

INJECTION PUMP ASSEMBLY

(See Components for Disassembly and Assembly)

1. MOUNT PUMP BODY TO SST (STAND)

SST 09241-76022 and 09245-54010

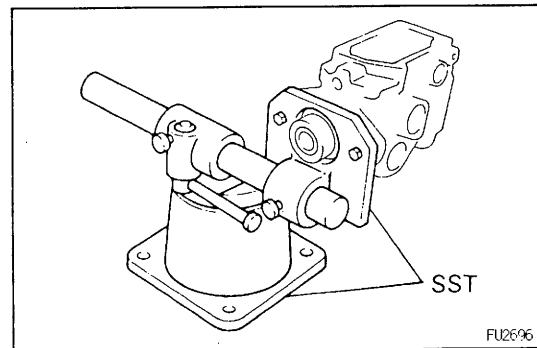
**2. INSTALL FUEL INLET HOLLOW SCREW**

Install a new gasket and the hollow screw.

Torque: 37 N·m (375 kgf·cm, 27 ft·lbf)

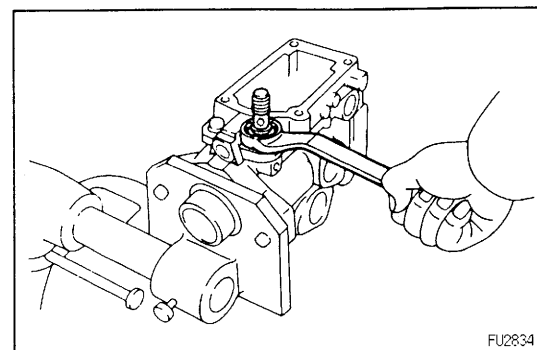
**3. INSTALL REGULATOR VALVE**

(a) Install the 2 O-rings to the regulator valve.

(b) Using SST, install the regulator valve.

SST 09260-54012 (09262-54020)

Torque: 8.8 N·m (90 kgf·cm, 78 in·lbf)

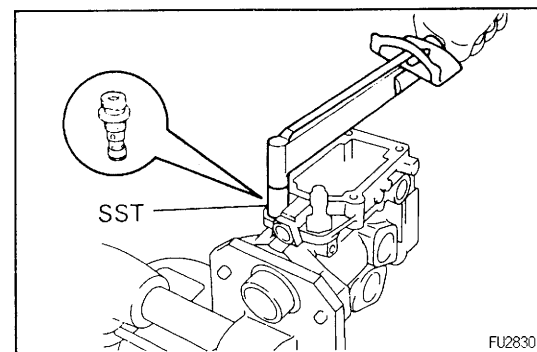
**4. INSTALL FUEL FEED PUMP**

(a) Install the liner, rotor and 4 blades.

(b) Check that the liner and blades are facing in the correct direction, as shown.

(c) Check that the blades move smoothly.

(d) Align the fuel outlet holes of the cover and liner.

(e) Install the pump cover with the 2 screws.

Torque: 2.5 N·m (25 kgf·cm, 22 in·lbf)

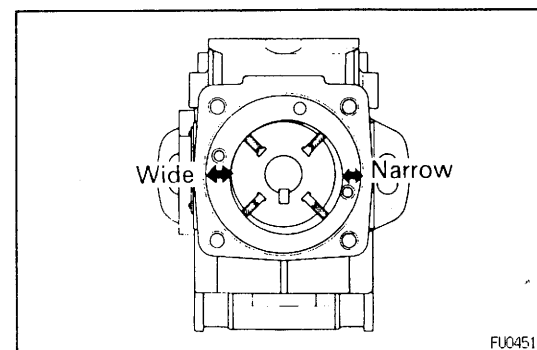

(f) Check that the rotor moves smoothly.

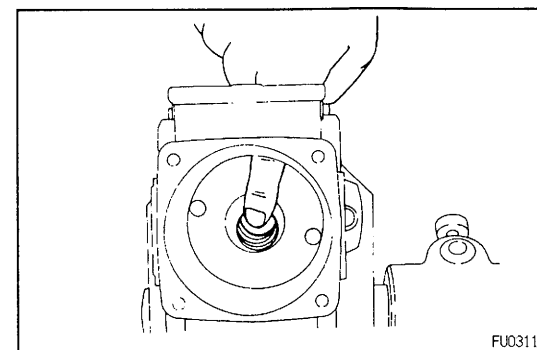
**5. INSTALL DRIVE SHAFT**

(a) Install the drive gear on the drive shaft as shown.

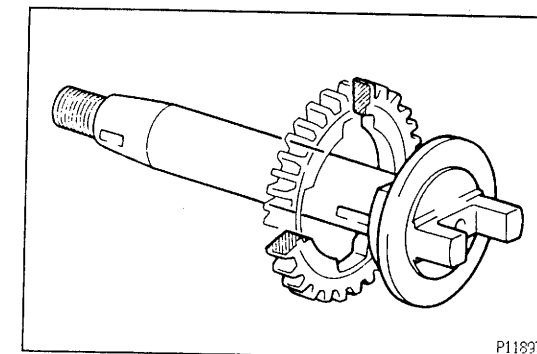

(b) Install 2 new joint rubbers into the drive gear.

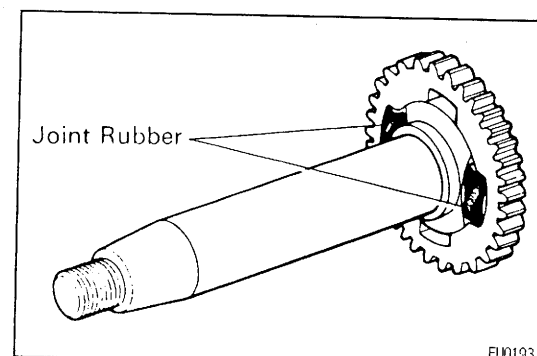

(c) Position the key groove of the feed pump rotor upward.

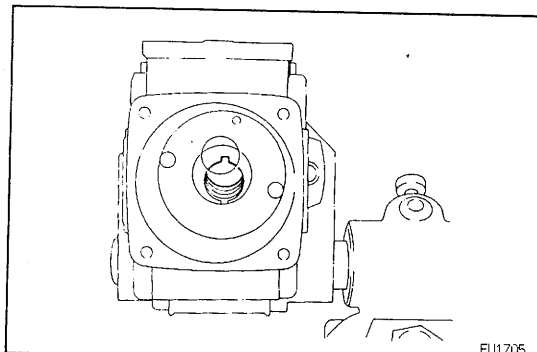

(d) Install the set key and drive shaft washer on the drive shaft and insert the drive shaft assembly into the pump housing.

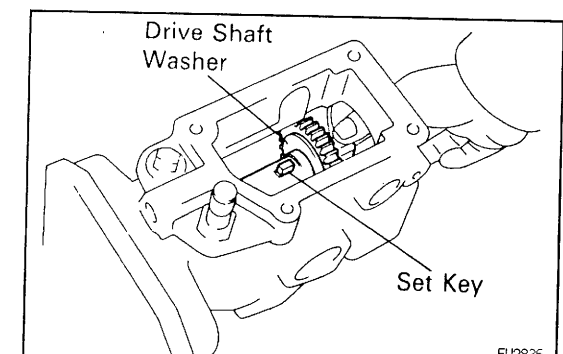

(e) Check that the drive shaft turns without catching.

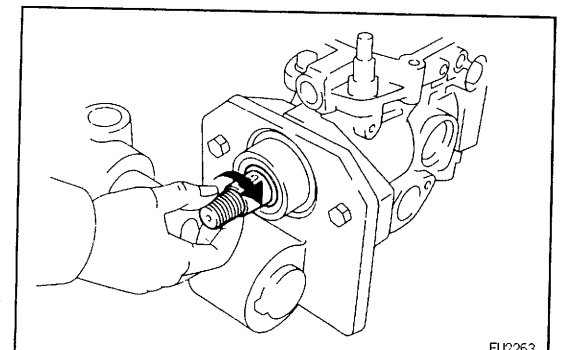

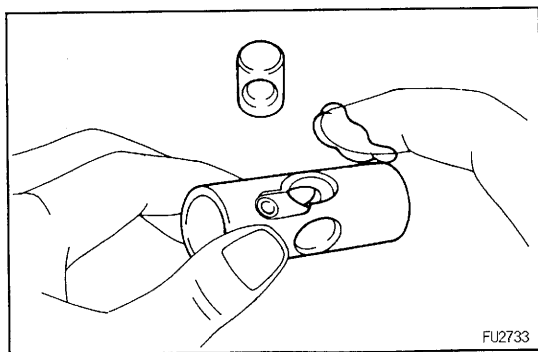
**6. INSTALL TIMER PISTON**

- (a) Apply grease to the timer piston.
- (b) Install the sub—piston into the timer piston.

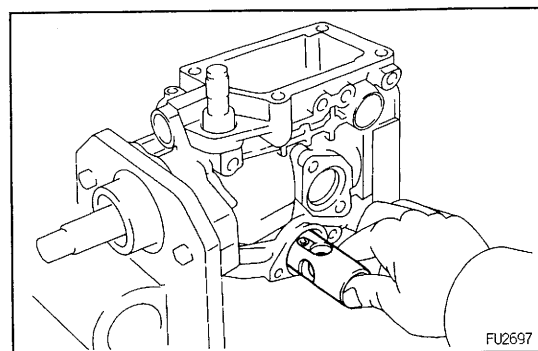

- (c) Insert the timer piston into the pump housing.

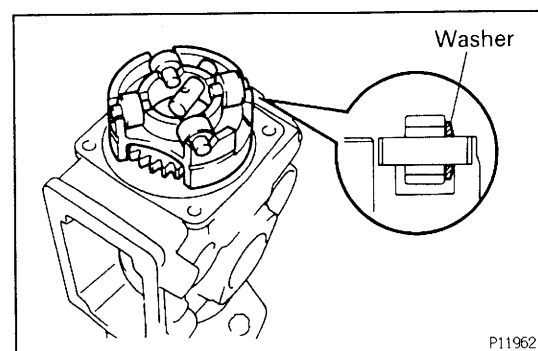
**7. INSTALL ROLLER RING**

- (a) Install the slide pin, 4 rollers and washers on the roller ring.
- (b) Check that the roller is facing the flat surface of the washer.
- (c) Install the roller ring into the pump housing.

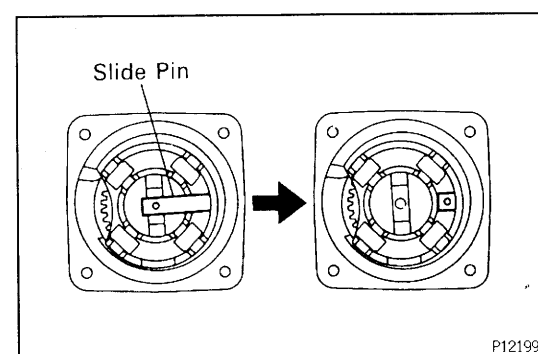

- (d) Carefully install the slide pin into the sub—piston.

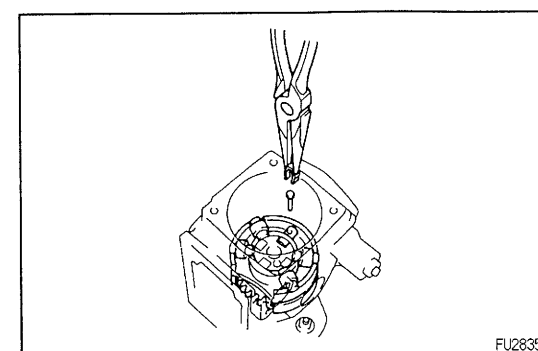

- (e) Install the stopper pin and clip.

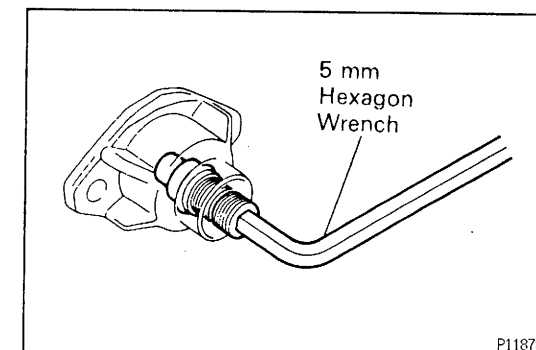
**8. INSTALL TIMER SPRING**

- (a) Install a new O—ring to the timer adjusting screw.
- (b) Using a 5 mm hexagon wrench, install the timer adjusting screw to the LH timer cover and temporarily install the nut.

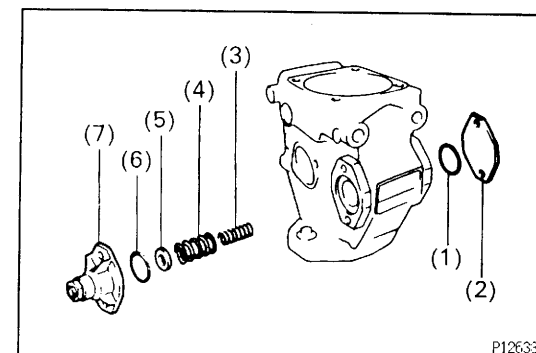

- (c) Install the following parts:

- (1) New O—ring
- (2) RH timer cover
- (3) Inner spring
- (4) Outer spring
- (5) Shim
- (6) New O—ring
- (7) LH timer cover, timer adjusting screw and nut assembly

- (d) Using a 5 mm hexagon wrench, install the 4 bolts.

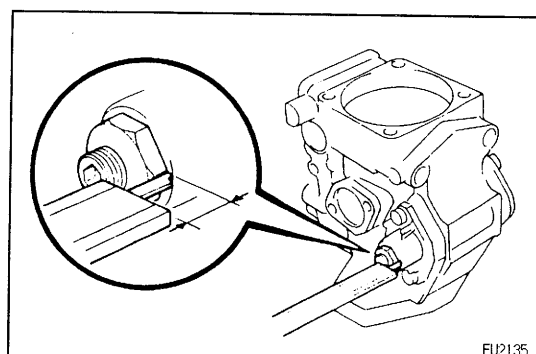
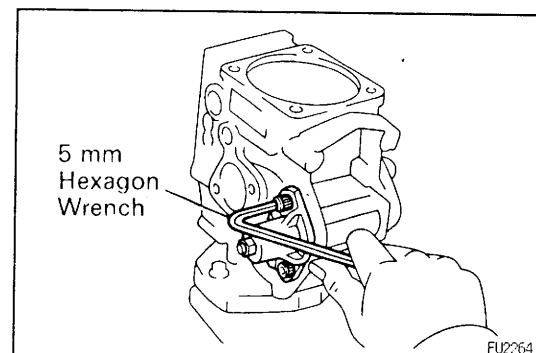
**9. PRESET TIMER ADJUSTING SCREW**

- (a) Using vernier calipers, measure the protrusion of the adjusting screw from the timer cover.

Protrusion:

7.5 — 8.0 mm (0.295 — 0.315 in.)

- (b) Using a 5 mm hexagon wrench, adjust the protrusion of the adjusting screw from the timer cover.

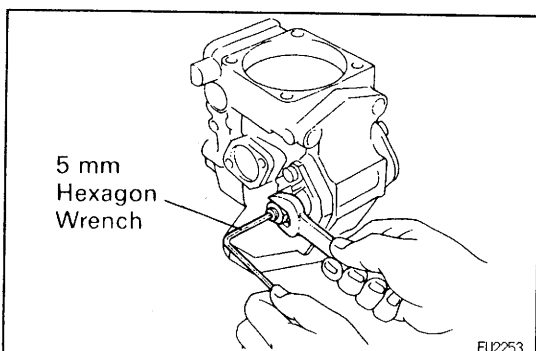

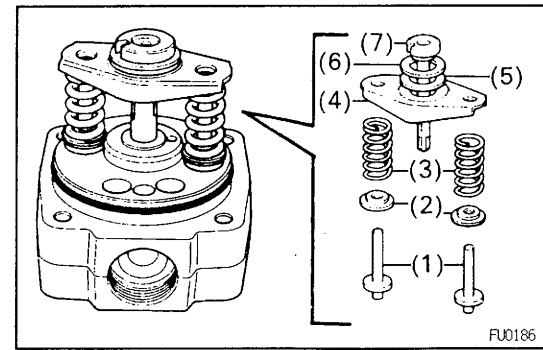

10. ADJUST PLUNGER SPRING SHIM

(a) Install the following parts to the distributive head:

- (1) 2 plunger spring guides
- (2) 2 upper spring seats
- (3) 2 plunger springs
- (4) Lower spring seat
- (5) Upper plunger plate
- (6) Lower plunger plate
- (7) Pump plunger

HINT: Do not assemble the plunger spring shims at this time.

(b) Using vernier calipers, measure clearance A indicated in the illustration.

(c) Determine the plunger spring shim size by using the following formula and chart.

$$\text{New plunger spring shim thickness} = 6.3 - A$$

A ... Measured plunger position

Plunger spring shim selection chart mm (in.)

Measured clearance	Shim thickness	Measured clearance	Shim thickness
More than 5.8 (0.228)	0.5 (0.020)	4.8 – 5.0 (0.189 – 0.197)	1.5 (0.059)
5.5 – 5.7 (0.217 – 0.224)	0.8 (0.031)	4.5 – 4.7 (0.177 – 0.185)	1.8 (0.071)
5.3 – 5.4 (0.209 – 0.213)	1.0 (0.039)	Less than 4.4 (0.173)	2.0 (0.079)
5.1 – 5.2 (0.201 – 0.205)	1.2 (0.047)	–	–

V03750

HINT:

- For a measurement between listed sizes, use the next larger size. Ex. If thickness is 1.1 mm (0.043 in.) by calculation, use a 1.2 mm (0.047 in.) shim.
- Select 2 shims which have the same thickness.

11. ADJUST PLUNGER ADJUSTING SHIM

(a) Install the coupling and face camplate.

HINT: Do not assemble the coupling spring.

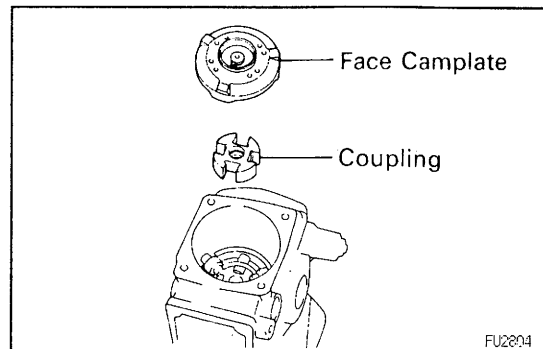

FU2204

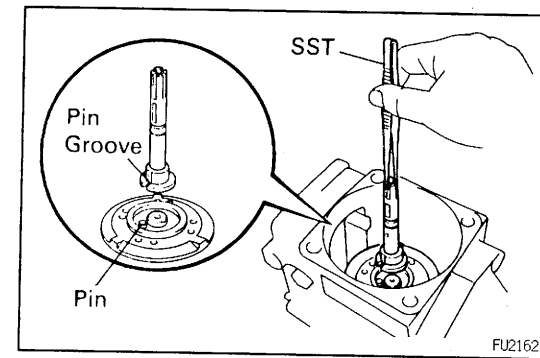

FU2162

- (b) Clean the plunger adjusting shim and contacting surface area.
- (c) Align the pin groove of the pump plunger with the face camplate pin.
- (d) Using SST, install the used plunger adjusting shim and pump plunger.
SST 09260–54012 (09269–54030)

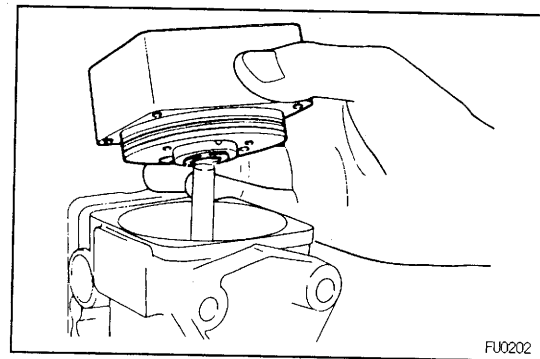

FU0202

- (e) Install the distributive head with the 4 bolts.
Torque: 12 N·m (120 kgf·cm, 9 ft·lbf)
NOTICE: Be careful not to damage the pump plunger.

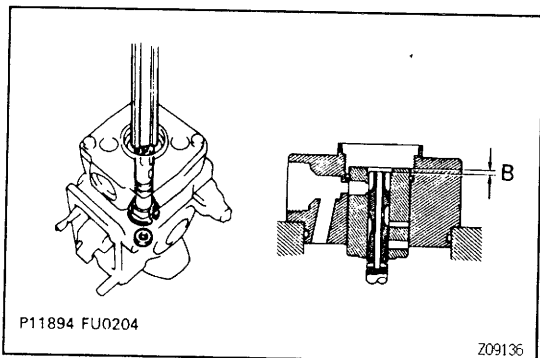

P11894 FU0204

Z09136

- (f) Using vernier calipers, measure dimension B indicated in the illustration.

- (g) Determine the plunger adjusting shim size by using the following formula and chart.
New adjusting shim thickness = T + (B – 3.3)
T ... Thickness of used shim
B ... Measured plunger position

Plunger adjusting shim selection chart

Installed shim mm	Measured clearance mm																			
	2.3	2.4	2.5	2.6	2.7	2.8	2.9	3.0	3.1	3.2-3.4	3.5	3.6	3.7	3.8	3.9	4.0	4.1	4.2	4.3	4.4
1.9											2.1	2.2	2.3	2.4	2.5	2.6	2.7	2.8	2.9	2.9
2.0									1.9		2.2	2.3	2.4	2.5	2.6	2.7	2.8	2.9	2.9	
2.1								1.9	1.9		2.3	2.4	2.5	2.6	2.7	2.8	2.9	2.9		
2.2							1.9	1.9	2.0		2.4	2.5	2.6	2.7	2.8	2.9	2.9			
2.3						1.9	1.9	2.0	2.1		2.5	2.6	2.7	2.8	2.9	2.9				
2.4				1.9	1.9	2.0	2.1	2.2	2.3		2.6	2.7	2.8	2.9	2.9					
2.5			1.9	1.9	2.0	2.1	2.2	2.3	2.4		2.7	2.8	2.9	2.9						
2.6		1.9	1.9	2.0	2.1	2.2	2.3	2.4			2.8	2.9	2.9							
2.7	1.9	1.9	2.0	2.1	2.2	2.3	2.4	2.5			2.9	2.9								
2.8	1.9	1.9	2.0	2.1	2.2	2.3	2.4	2.5	2.6		2.9									
2.9	1.9	2.0	2.1	2.2	2.3	2.4	2.5	2.6	2.7											

Plunger adjusting shim thickness mm (in.)	1.9 (0.075)	2.0 (0.079)	2.1 (0.083)	2.2 (0.087)	2.3 (0.091)	2.4 (0.094)	2.5 (0.098)	2.6 (0.102)	2.7 (0.106)	2.8 (0.110)	2.9 (0.114)
--	----------------	----------------	----------------	----------------	----------------	----------------	----------------	----------------	----------------	----------------	----------------

V03690

EXAMPLE: The 2.4 mm (0.094 in.) shim is installed and measured clearance is 3.7 mm (0.146 in.). Replace the 2.4 mm (0.094 in.) shim with a 2.8 mm (0.110 in.) shim.

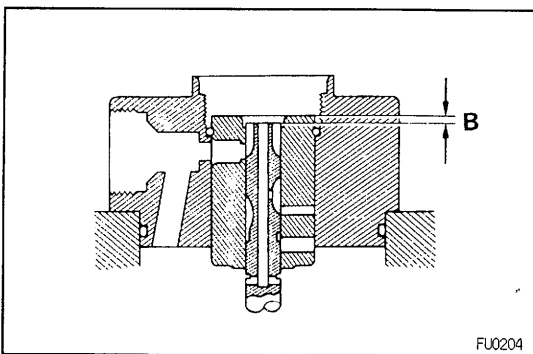

FU0204

- (h) Install a new plunger adjusting shim and recheck dimension B.
Dimension B:
 3.2 – 3.4 mm (0.126 – 0.134 in.)

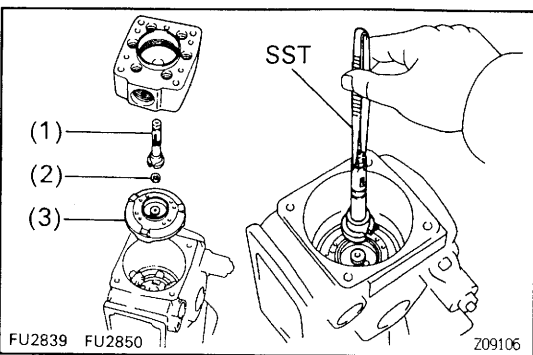

Z09106

- (i) Remove the distributive head.
 (j) Using SST, remove the following parts:
 (1) Pump plunger
 (2) Plunger adjusting shim
 (3) Face camplate
 SST 09260-54012 (09269-54030)

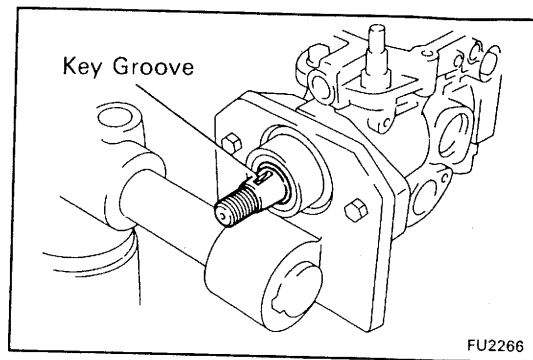

FU2266

12. INSTALL FACE CAMPLATE

- (a) Face the drive shaft with the key groove facing upward.

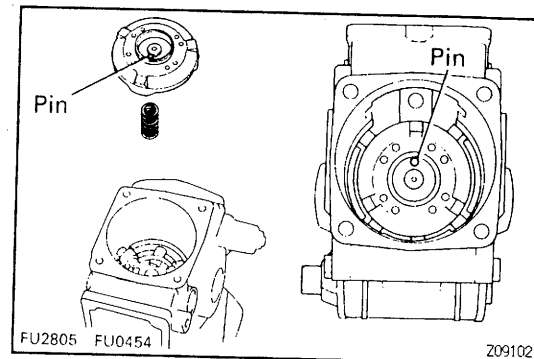

FU2805 FU0454

Z09102

- (b) Install the coupling spring and camplate with the camplate pin facing the governor cover side.

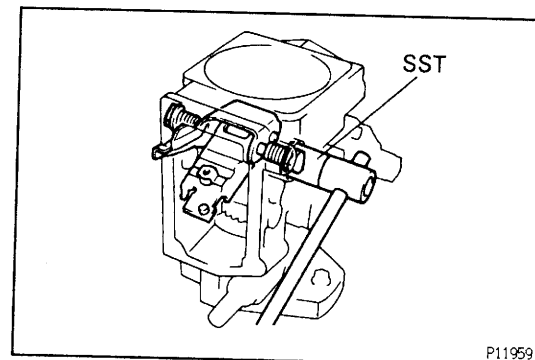

P11959

13. INSTALL GOVERNOR LINK

- (a) Using SST, install the governor link with 2 new gaskets and the 2 support bolts.
Torque: 14 N·m (140 kgf·cm, 10 ft·lbf)
 SST 09260-54012 (09269-54040)
 (b) Check that the governor link moves smoothly.

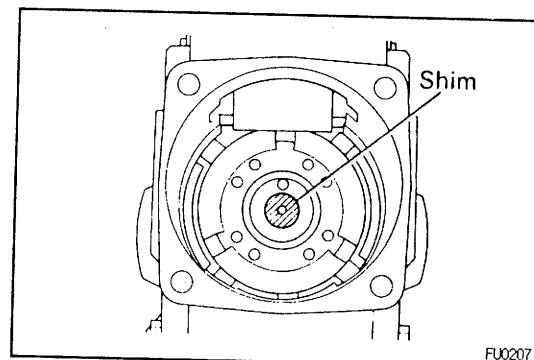

FU0207

14. INSTALL PUMP PLUNGER

- (a) Place the selected new plunger adjusting shim on the center of the camplate.
NOTICE: Do not apply grease to the shim.

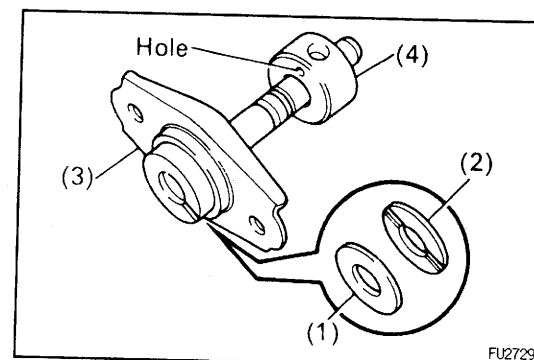

FU2729

- (b) Install the following parts to the pump plunger:
 (1) Lower plunger plate
 (2) Upper plunger plate
 (3) Lower spring seat
 (4) Spill ring
HINT: Face the spill ring with the hole facing the lower spring seat.

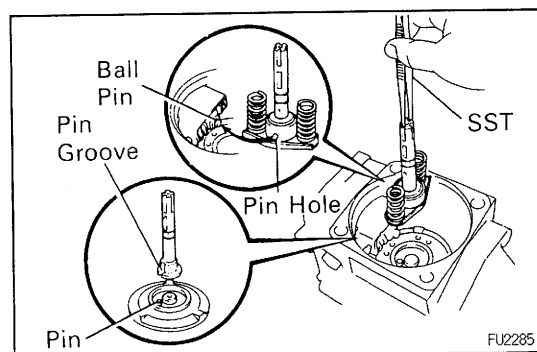

- (c) Align the pin groove of the plunger with the pin of the face camplate.
- (d) Align the ball pin of the governor link with the pin hole of the spill ring.
- (e) Using SST, install the pump plunger and 2 plunger springs.
SST 09260-54012 (09269-54030)

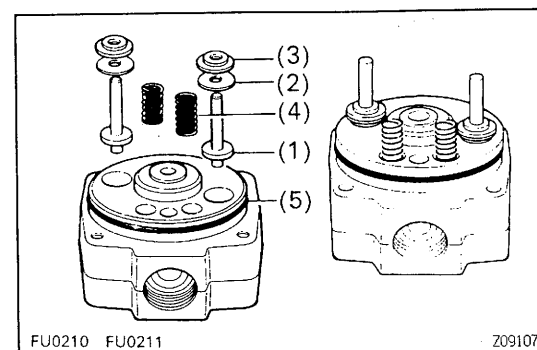

15. INSTALL DISTRIBUTIVE HEAD

- (a) Apply grease to the following parts and install them to the distributive head:
 - (1) 2 plunger spring guides
 - (2) 2 new selected plunger spring shims
 - (3) 2 upper spring seats
 - (4) 2 lever support springs
 - (5) New O-ring

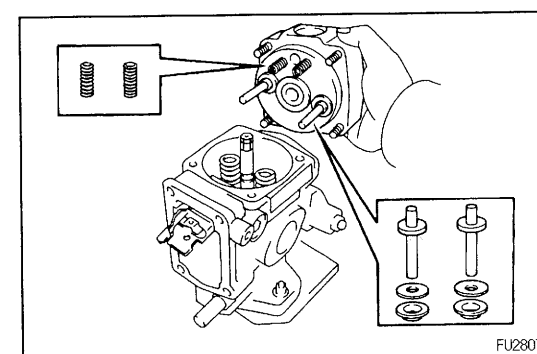

- (b) Install the distributive head.
NOTICE: Be careful not to damage the pump plunger.

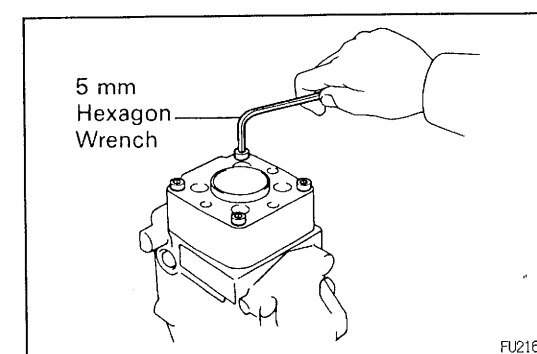

- (c) Using a 5 mm hexagon wrench, install the 4 bolts.
Torque: 12 N·m (120 kgf·cm, 9 ft·lbf)
HINT: Use the bolt which is 45 mm (1.77 in.) in length.

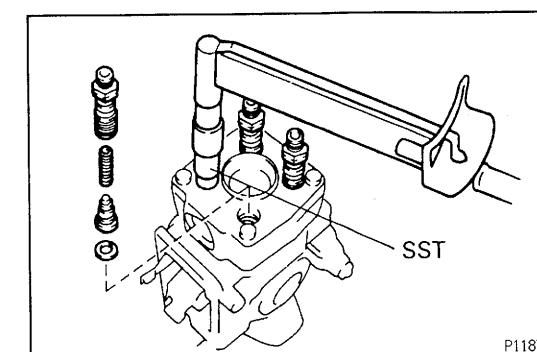

16. INSTALL DELIVERY VALVE HOLDERS

- (a) Install new gaskets and the valves into the distributive head.
- (b) Install the springs into the delivery valve holders.
- (c) Using SST, install the delivery valve holders.
SST 09260-54012 (09269-54020)
Torque: 59 N·m (600 kgf·cm, 43 ft·lbf)

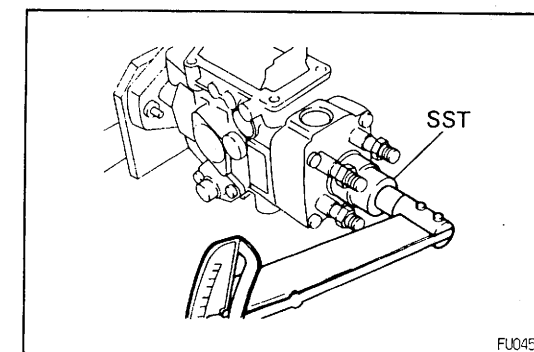

17. INSTALL DISTRIBUTIVE HEAD PLUG

- (a) Install a new O-ring to the head plug.
- (b) Using SST, install the head plug.
SST 09260-54012 (09262-54010)
Torque: 88 N·m (900 kgf·cm, 65 ft·lbf)

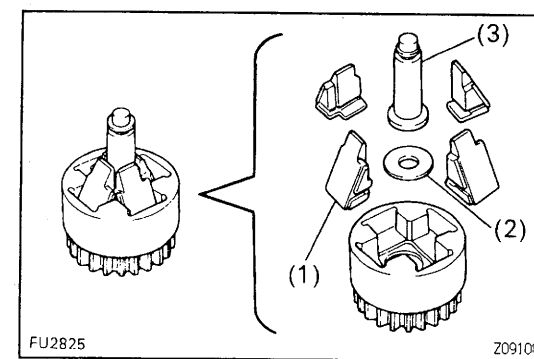

18. INSTALL GOVERNOR SHAFT AND FLYWEIGHT HOLDER

- (a) Install the following parts to the flyweight holder:
 - (1) 4 flyweight
 - (2) No.2 flyweight washer
 - (3) Governor sleeve
- HINT: Replace the 4 flyweights as a set.

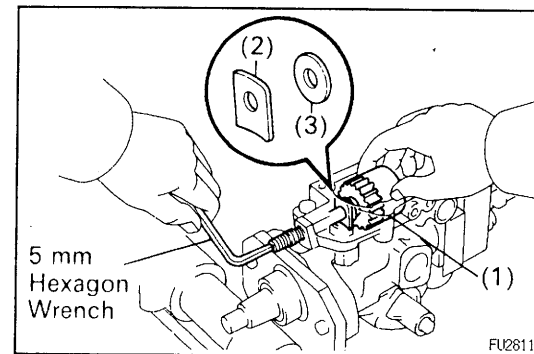

- (b) Install a new O-ring to the governor shaft.
- (c) Place the flyweight holder assembly (1) in position, and install the governor gear adjusting washer (2) and No. 1 flyweight washer (3) between the flyweight holder and pump housing.
- (d) Install the governor shaft through the governor gear adjusting washer, No. 1 flyweight washer and flyweight holder assembly.
- (e) Using a 5 mm hexagon wrench, turn the governor shaft counterclockwise.

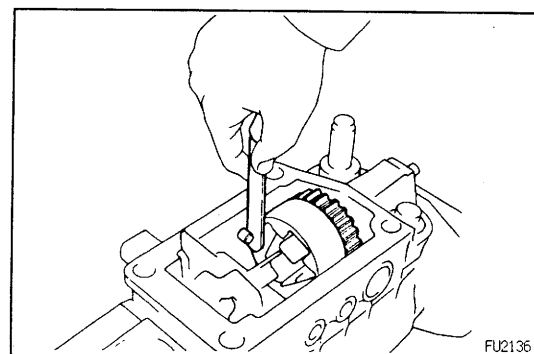

19. CHECK FLYWEIGHT HOLDER THRUST CLEARANCE

Using a thickness gauge, measure the thrust clearance between the housing pin and flyweight holder.
Thrust clearance:

0.15 - 0.35 mm (0.0059 - 0.0138 in.)

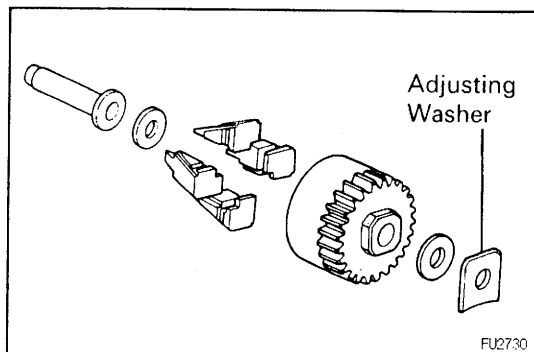

If the thrust clearance is not as specified, adjust with a governor gear adjusting washer.

Governor gear adjusting washer thickness:

1.05 mm (0.0413 in.)

1.25 mm (0.0492 in.)

1.45 mm (0.0571 in.)

1.65 mm (0.0650 in.)

1.85 mm (0.0728 in.)

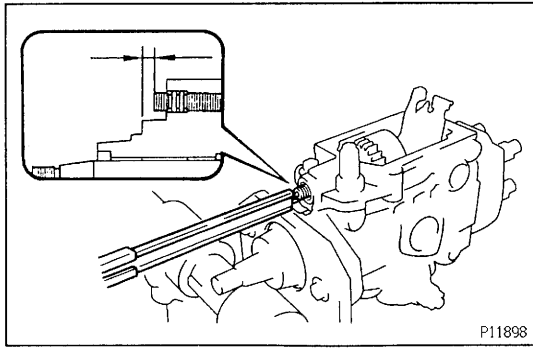

20. ADJUST PROTRUSION OF GOVERNOR SHAFT

- (a) Using vernier calipers, measure the protrusion of the governor shaft.

Protrusion:

0.5 – 2.0 mm (0.020 – 0.079 in.)

If the protrusion is not as specified, adjust by turning the governor shaft.

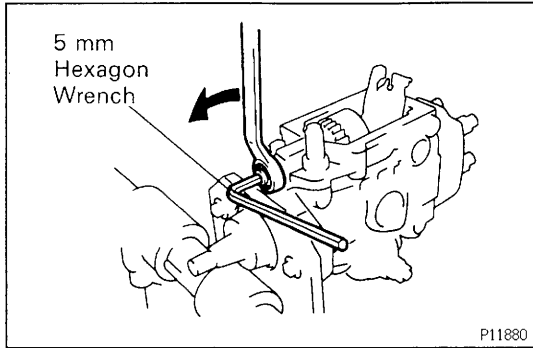

- (b) Install and tighten the nut while holding the governor shaft with a 5 mm hexagon wrench.

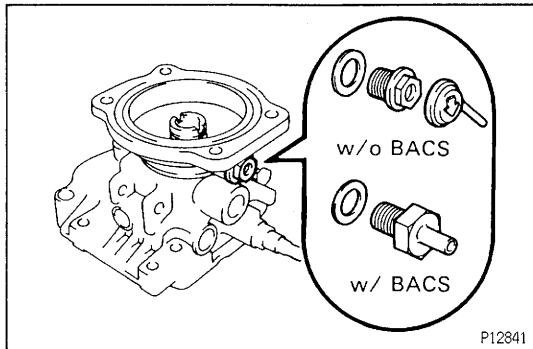

21. ASSEMBLE BOOST COMPENSATOR

A. Install overflow screw

- (a) Install the overflow screw with a new gasket.
 (b) w/o BACS:
 Install the rubber cap facing the arrow downward.

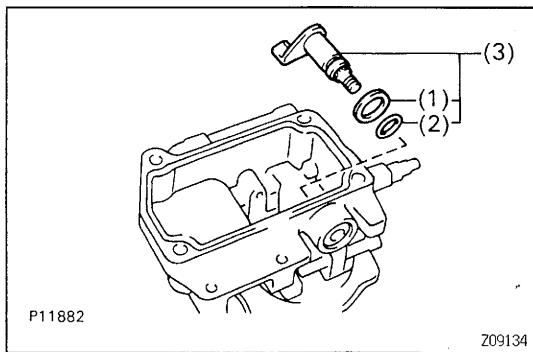

B. Install No.2 PCS lever

Install the following parts to the governor cover:

- (1) Washer
 (2) O-ring
 (3) No.2 PCS lever, O-ring and washer assembly

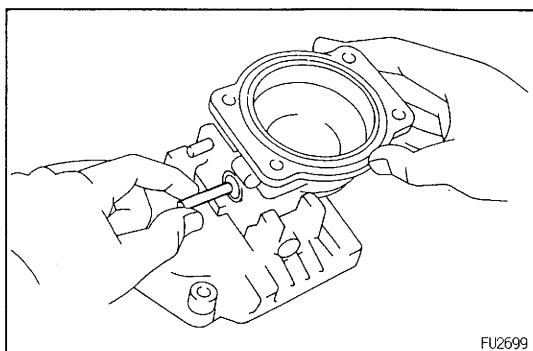

C. Install control lever

- (a) Insert the connecting pin into the governor cover.

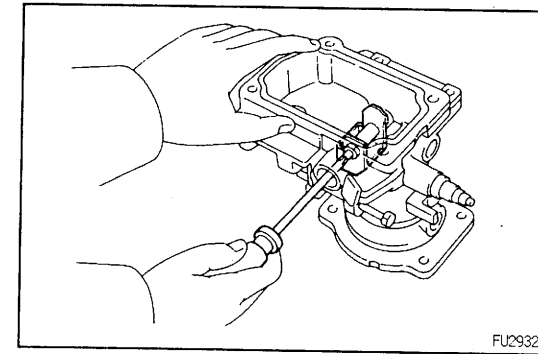

- (b) Using a small screwdriver, install the control lever with the support pin.

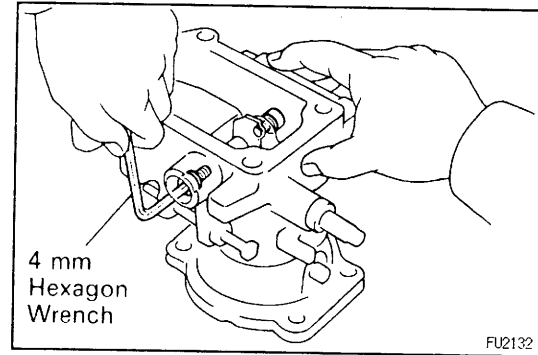

- (c) Using a 4 mm hexagon wrench, install 2 new gaskets and the 2 bolts.

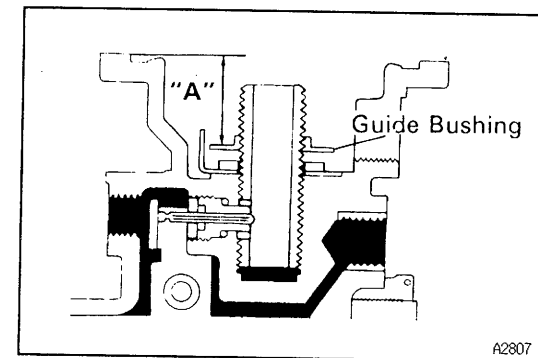

D. Install guide bushing

Install and adjust the guide bushing to the dimension "A" as shown in the illustration.

Dimension "A":

Europe 18.4 – 19.4 mm (0.724 – 0.764 in.)

Others 17.4 – 18.4 mm (0.685 – 0.724 in.)

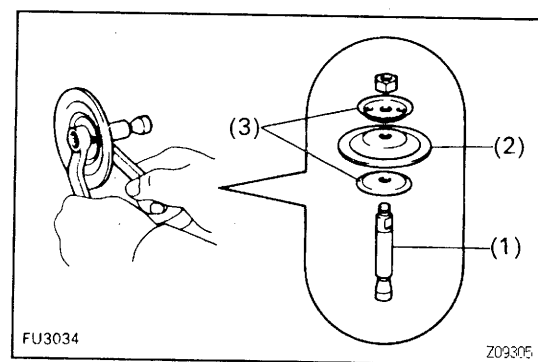

E. Install boost compensator diaphragm

- (a) Assemble the following parts with the nut.

- (1) Push rod
 (2) Diaphragm
 (3) 2 spring seats

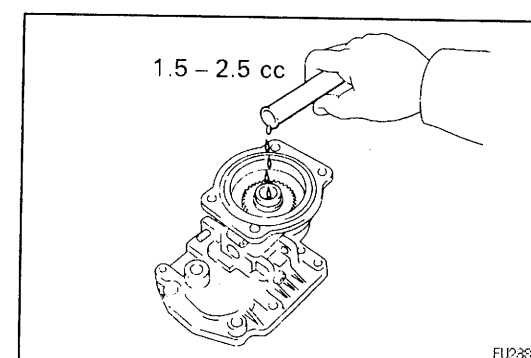

- (b) Insert 1.5 – 2.5 cc (0.09 – 0.15 cu in.) of engine oil into the bushing hole.

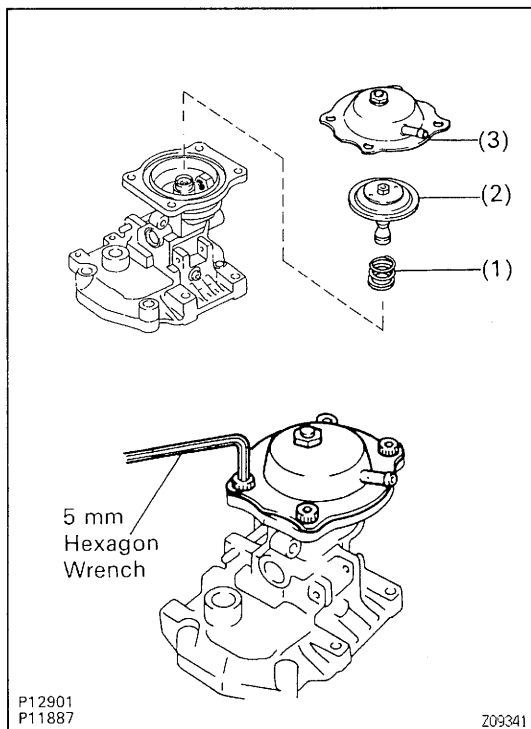

- (c) Using a 5 mm hexagon wrench, install the following parts to the governor cover with the 4 bolts:
- (1) Spring
 - (2) Diaphragm assembly
 - (3) Diaphragm cover

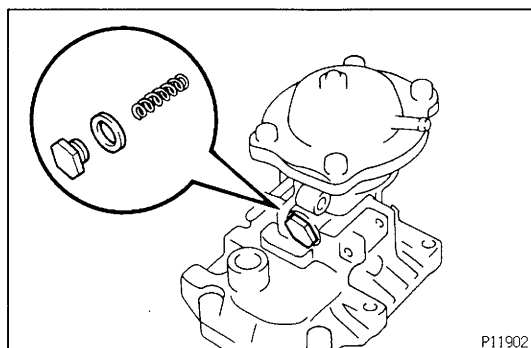

- F. Install lever control spring**
Install the lever control spring with a new gasket and the bolt.

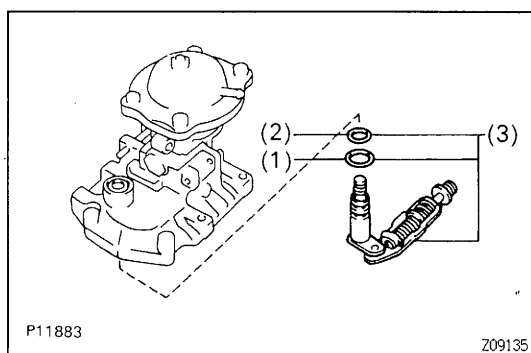

- 22. INSTALL ADJUSTING LEVER SHAFT TO GOVERNOR SHAFT**
Install the following parts to the governor cover:
- (1) Washer
 - (2) New O-ring
 - (3) Adjusting lever shaft, O-ring and plate washer assembly

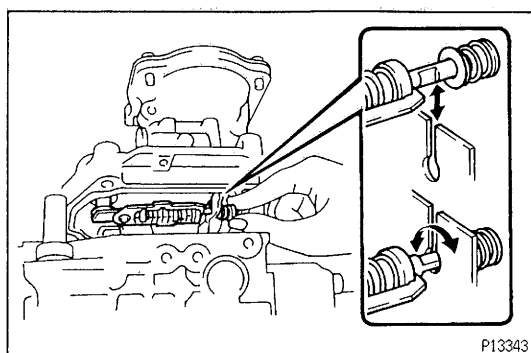

- 23. INSTALL GOVERNOR COVER**
- (a) Install a new gasket to the groove of the governor cover.
 - (b) Connect the adjusting lever shaft to the governor link and twist the shaft lightly.

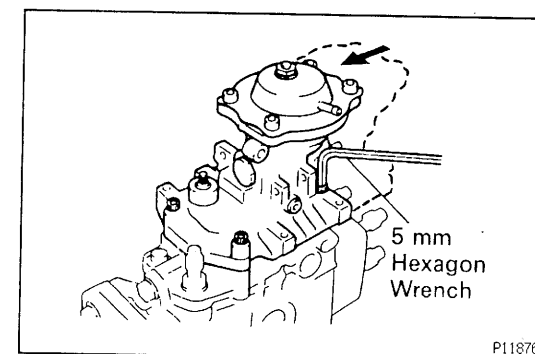

- (c) Using a 5 mm hexagon wrench, install the governor cover with the 4 bolts.
Torque: 8.3 N·m (85 kgf·cm, 74 in.·lbf)
HINT: Use the bolt which is 35 mm (1.38 in.) length.

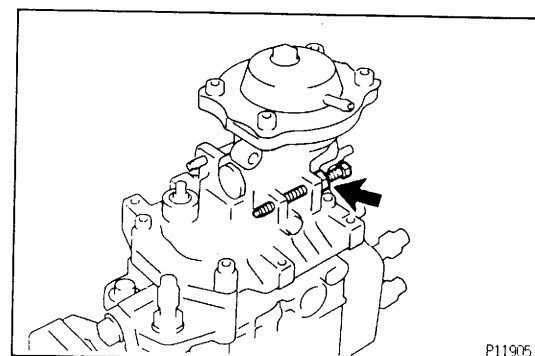

- (d) Install the idle speed adjusting screw with the lock nut.

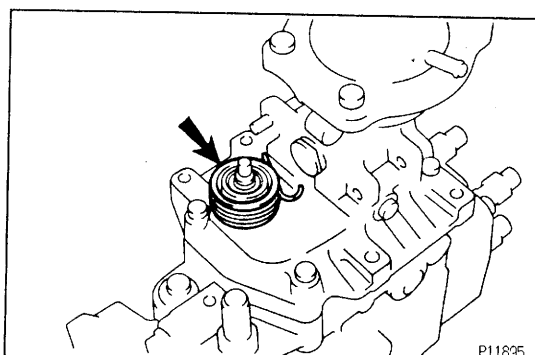

24. INSTALL ADJUSTING LEVER

- (a) Place the return spring guide and return spring on the governor cover.

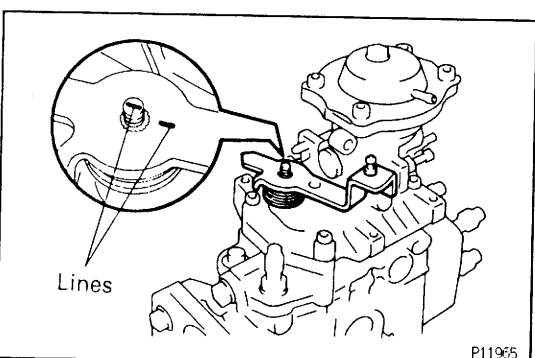

- (b) Align the lines of the adjusting lever shaft and adjusting lever.

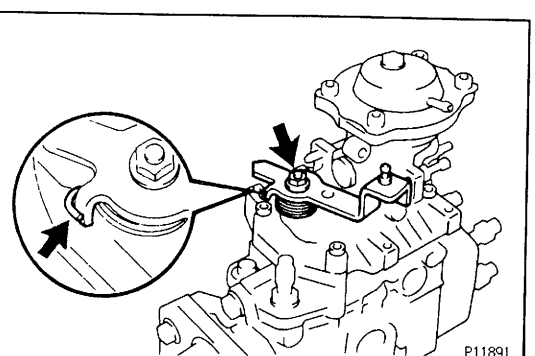

- (c) Install the nut.
(d) Hook the return spring to the adjusting lever.

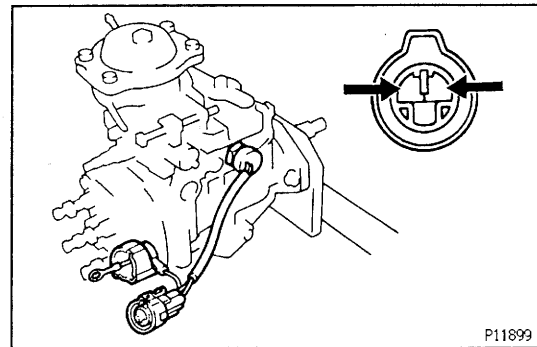
**25. INSTALL PICKUP SENSOR**

- (a) Connect the sensor lead wires to the connector.
 - (b) Install a new O-ring and pickup sensor.
- Torque: 21 N·m (210 kgf·cm, 15 ft·lbf)**

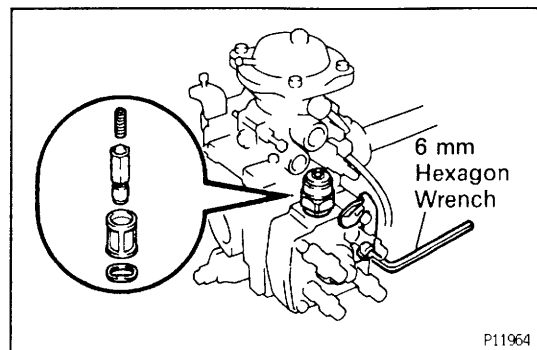
**26. INSTALL FUEL CUT SOLENOID**

- (a) Install a new O-ring on the fuel cut solenoid.
 - (b) Install the wave washer, strainer, valve, spring and fuel cut solenoid.
- Torque: 22 N·m (225 kgf·cm, 16 ft·lbf)**
- (c) Using a 6 mm hexagon wrench, install the connector bracket with the bolt.

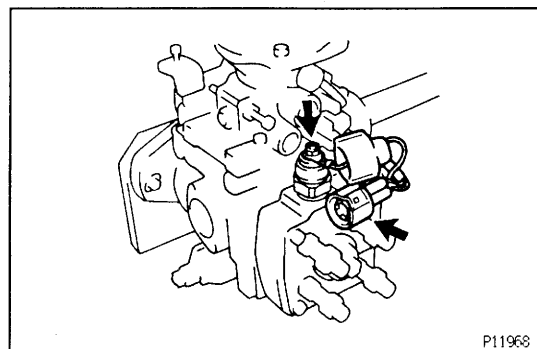

- (d) Install the lead wire to the fuel cut solenoid with the nut.
- (e) Install the dust cover to the fuel cut solenoid.
- (f) Install the lead wire connector to bracket.

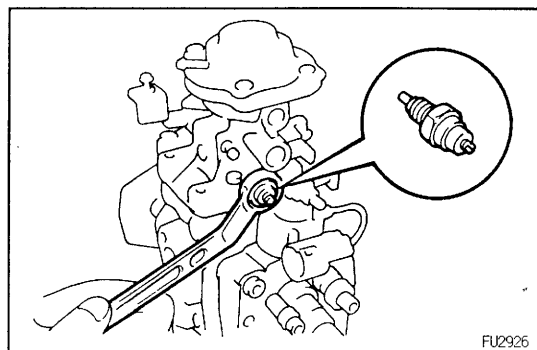
**27. INSTALL DASH POT**

Install a new gasket and the dash pot.
Torque: 11 N·m (115 kgf·cm, 8 ft·lbf)

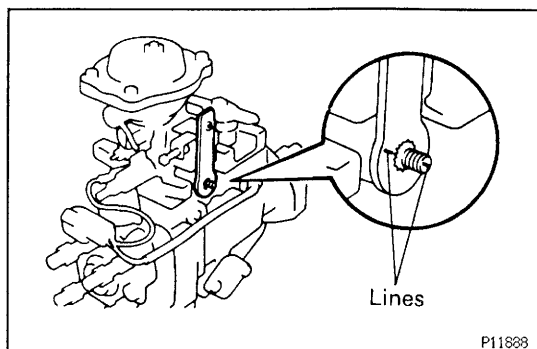
**28. INSTALL NO.1 PCS LEVER**

- (a) Align the lines of the levers.

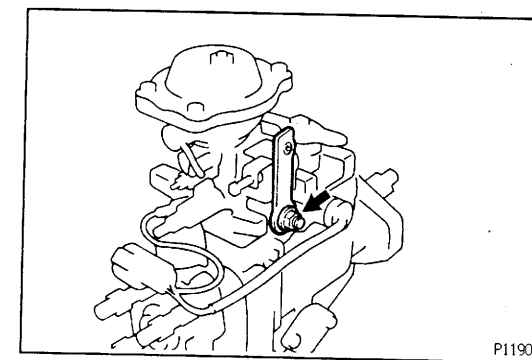

- (b) Install the nut.

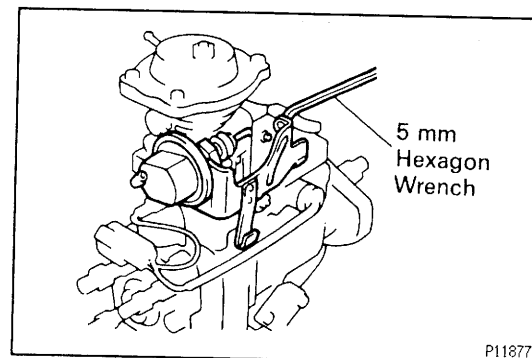
**29. INSTALL PCS ACTUATOR**

- (a) Using a 5 mm hexagon wrench, install the PCS actuator assembly with the 2 bolts.

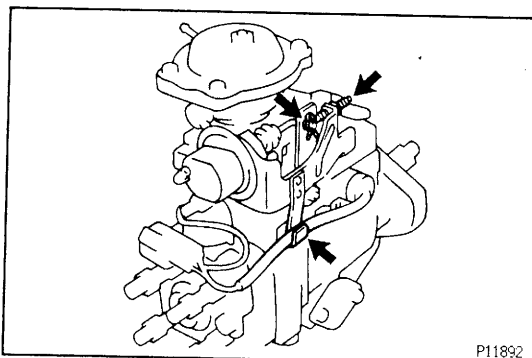

- (b) Install the clip.
- (c) Install the PCS adjusting screw.
- (d) Connect the wire harness.

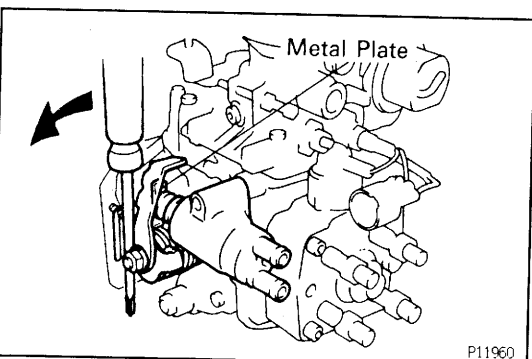
**30. INSTALL THERMO WAX**

- (a) Using a screwdriver, turn the cold starting lever counterclockwise approx. 20°.
- (b) Put a metal plate (thickness of 8.5 – 10 mm (0.33 – 0.39 in.)) between the cold starting lever and thermo wax plunger.

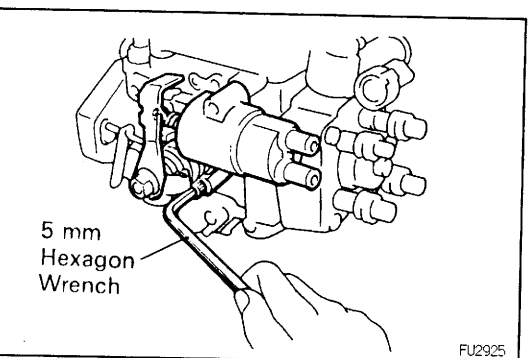

- (c) Install a new O-ring to the pump body.
- (d) Using a 5 mm hexagon wrench, install the thermo wax with the 2 bolts.

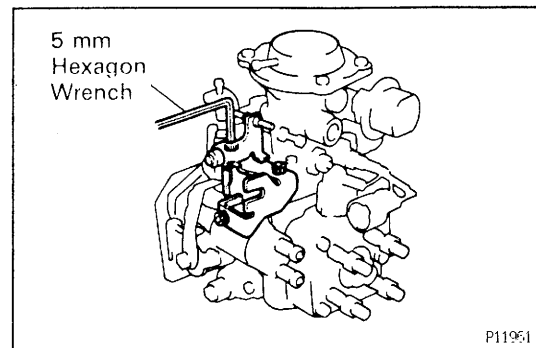
**31. INSTALL IDLE-UP LEVER**

Using a 5 mm hexagon wrench, install the idle-up lever with the 3 bolts.

32. w/ A/C:**INSTALL IDLE-UP ACTUATOR****33. REMOVE INJECTION PUMP FROM SST (STAND)**

SST 09241-76022 and 09245-54010

34. PERFORM AIR TIGHT TEST

- (a) Install a bolt to the overflow port.
- (b) Install the plug to each port of the boost compensator and PCS actuator.

- (c) Connect an air hose to the fuel inlet pipe and place the injection pump into diesel fuel.
- (d) Apply 49 kPa (0.5 kgf/cm², 7 psi) of pressure and confirm that there are no leaks.
- (e) Next check that there are no leaks with 490 kPa (5.0 kgf/cm², 71 psi) of pressure applied.

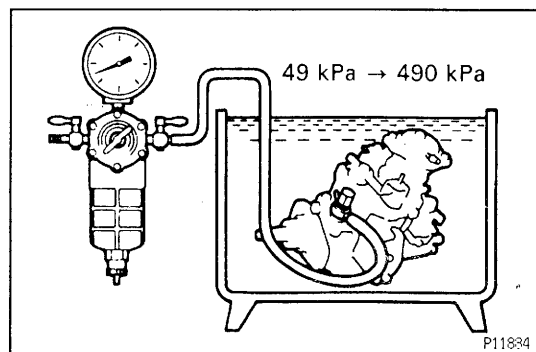
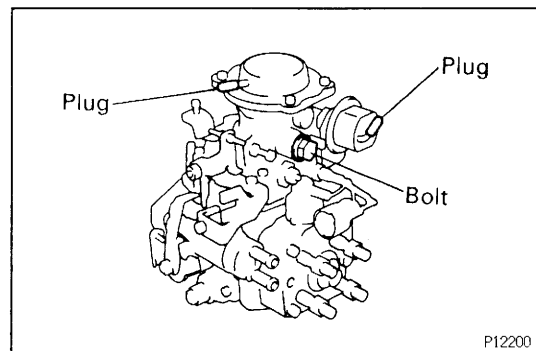
35. INSTALL SET KEY OF INJECTION PUMP DRIVE PULLEY ON DRIVE SHAFT**INJECTION PUMP ADJUSTMENT****1. PRE-TEST CHECK AND PREPARATION**

- (a) The specifications for test nozzle and nozzle holders are as follows.

Test nozzle:

DN12SD12 (NIPPONDENSO)

Test nozzle opening pressure:

14.220 – 15.200 kPa

(145 – 155 kgf/cm², 2,062 – 2,205 psi)

- (b) Check the accuracy of the tachometer.

Allowable error:

± 40 rpm

- (c) Install the angle gauge stand.

- (d) Mount the injection pump body on the pump tester.

HINT: Place a mark on the key groove portion of the coupling.

- (e) Install an injection pipe with the following specifications.

Outer diameter:

6.0 mm (0.236 in.)

Inner diameter:

2.0 mm (0.079 in.)

Length:

840 mm (33.07 in.)

Minimum bending radius:

25 mm (0.98 in.) or more

- (f) Remove the fuel inlet hollow screw.

- (g) Connect the fuel inlet pipe with an adapter.

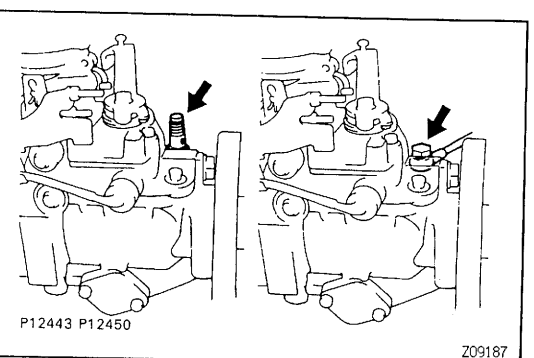
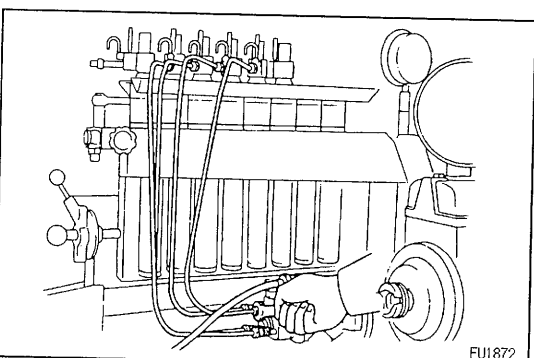
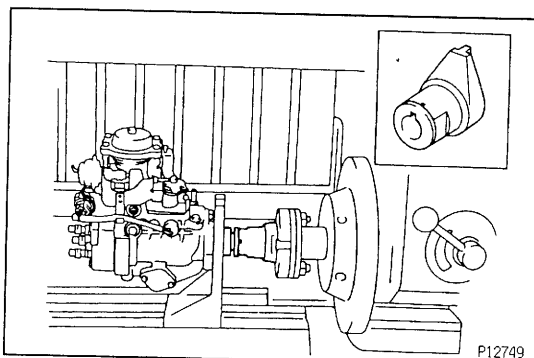
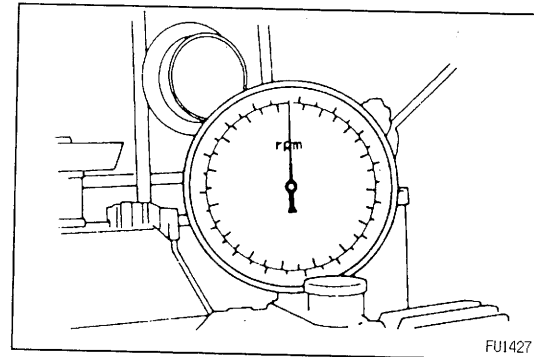
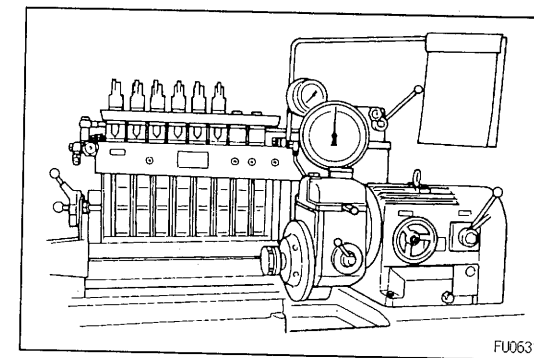

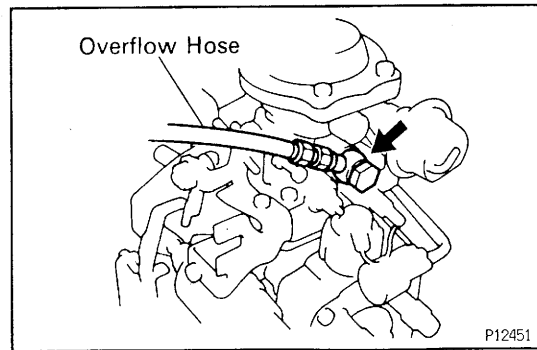

- (h) Install an overflow hose with 2 new gaskets and union bolt.
 HINT: Always use the overflow screw installed on the pump to be adjusted.

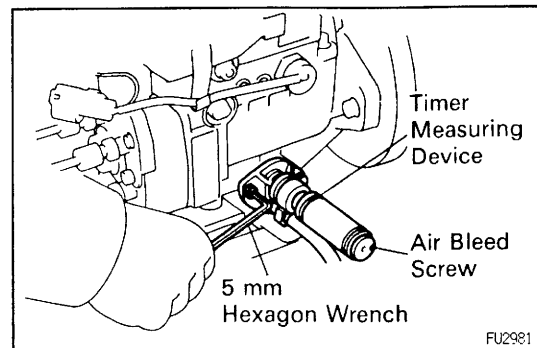

- (i) Using a 5 mm hexagon wrench, remove the 2 bolts and RH timer cover.
 (j) Install the inner pressure gauge with the timer measuring device.
 Part No. 95095-10220 and 95095-10231 (NIPPONDENSO)
 HINT: Bleed the air by the air bleed screw.
 (k) Connect SST (turbocharger pressure gauge) to the boost compensator.
 SST 09992-00241

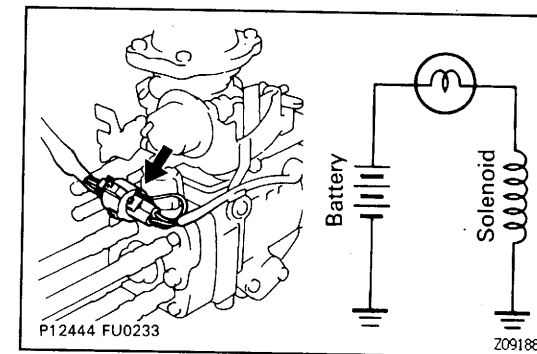
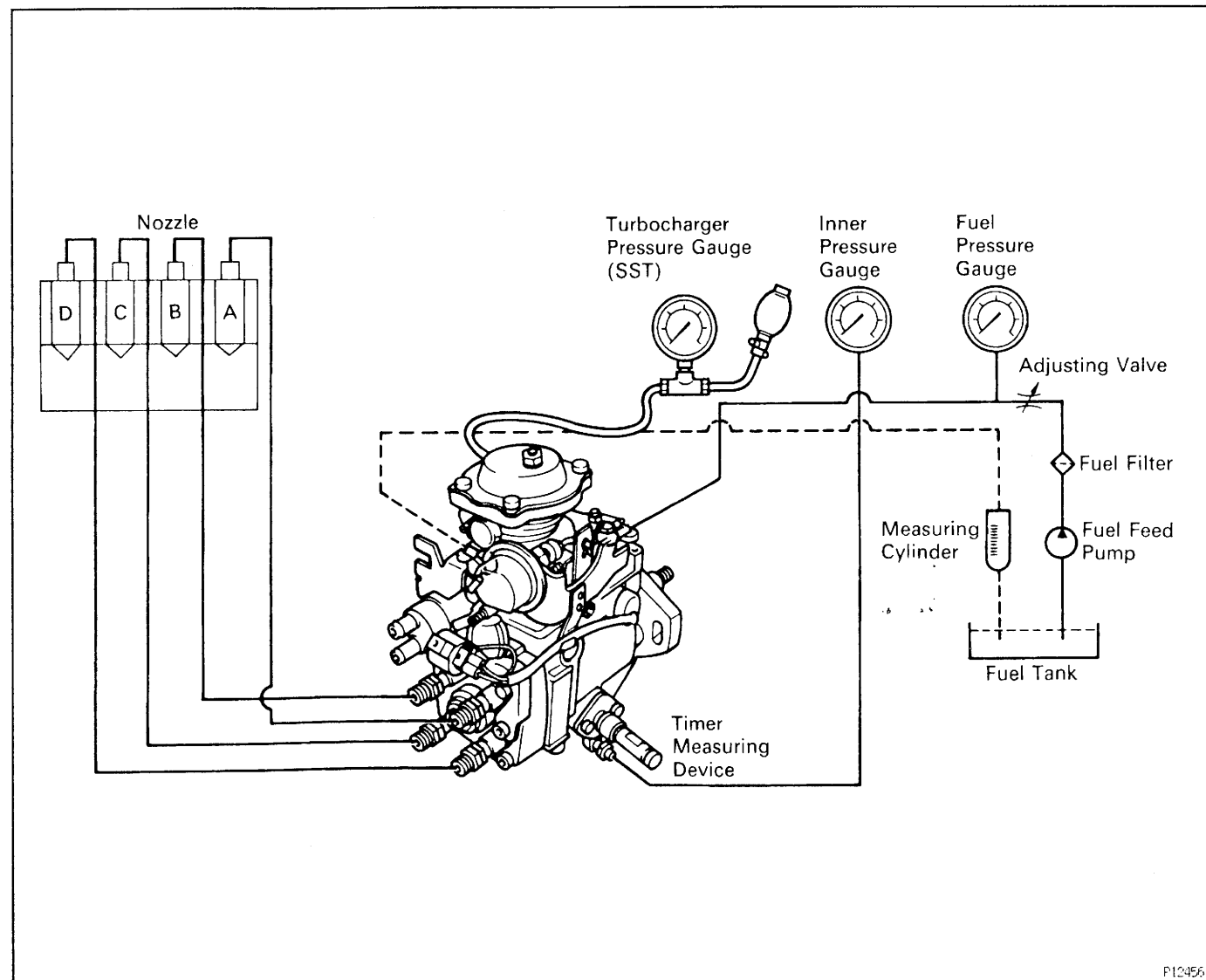

- (l) Apply about 6 volts of DC power to the fuel cut solenoid.
NOTICE:
- When applying voltage to the solenoid, position the battery as far away from the solenoid as possible so that a spark does not occur.
 - When connecting the battery cable, connect the solenoid side first.

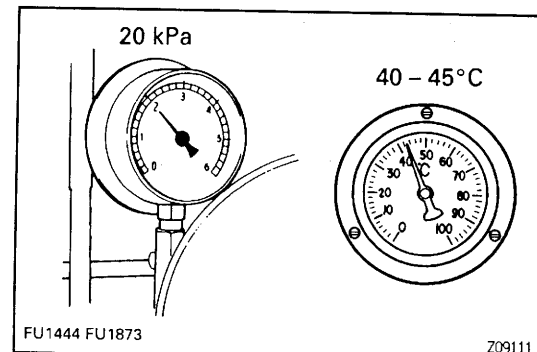

- (m) The pressure for feeding fuel to the injection pump should be 20 kPa (0.2 kgf/cm², 2.8 psi). The fuel temperature for pump testing should be 40 – 45°C (104 – 113°F).

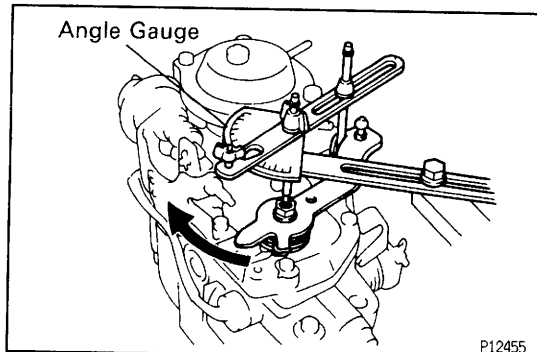

- (n) Install an angle gauge to the stand and set it to the adjusting lever.
 Part No. 95095-10360 (Stand w/ angle gauge)
 (o) Secure the adjusting lever fully on the maximum speed side.

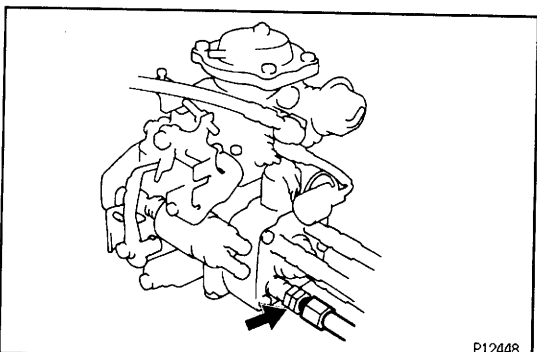

- (p) Check the installation direction of the camplate as follows:
- Disconnect the injection pipe from the position marked "C" on the distributive head.

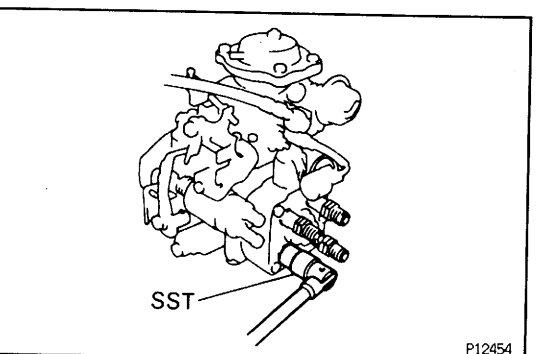

- Using SST, remove the delivery valve holder.
 SST 09260-54012 (09269-54020)

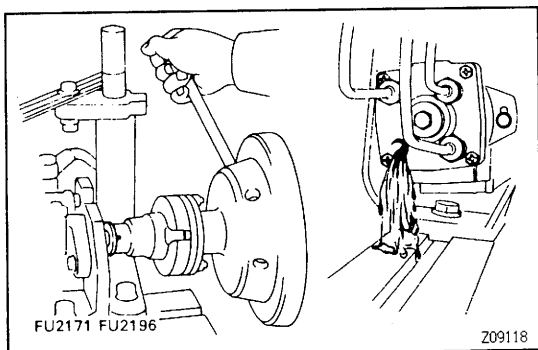

- Check that fuel is flowing out when the mark is in the position shown in the illustration. If not, it is improperly assembled.
 - Disassemble and change the camplate position 180° in the opposite direction.
- HINT: At this time, disconnect the fuel cut solenoid wire harness.

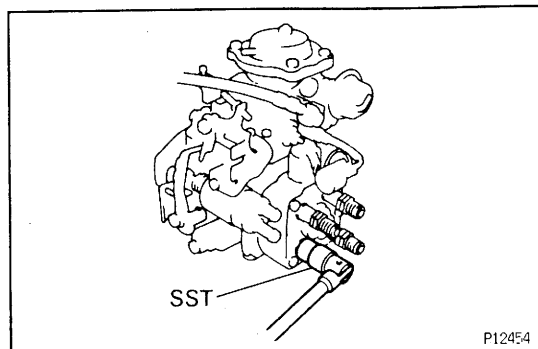

- Using SST, install the delivery valve holder.
SST 09260-54012 (09269-54020)
Torque: 59 N·m (600 kgf·cm, 43 ft·lbf)

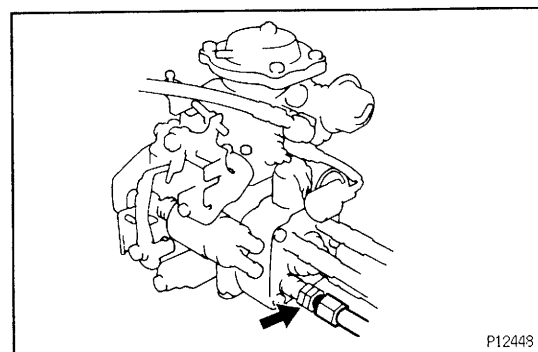

- Connect the injection pipe.

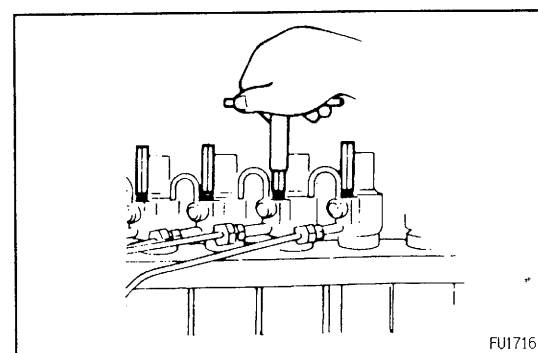

- (q) Bleed the air from the injection pipes.

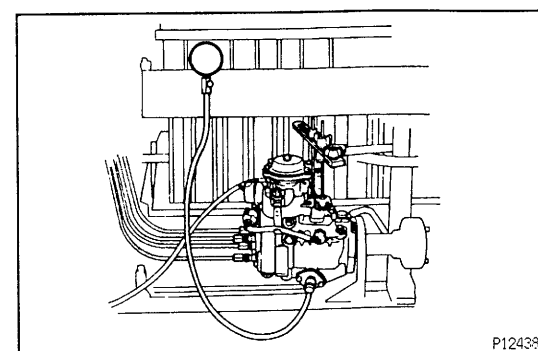

- (r) Race the injection pump for 5 minutes at 1,200 rpm.
NOTICE: Check that there is no fuel leakage or abnormal noise.

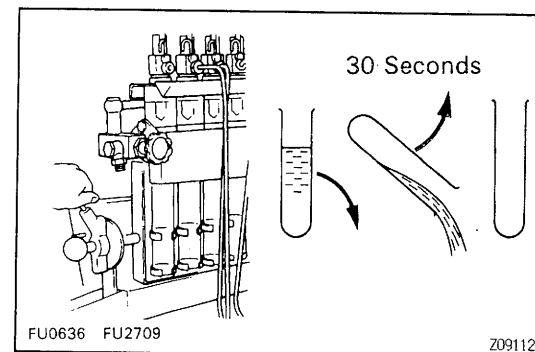

HINT:

- Measure the volume of each injection cylinder with a measuring cylinder.
- Before measuring the injection volume, first hold the cylinder tilted for at least 30 seconds to discard all the fuel.

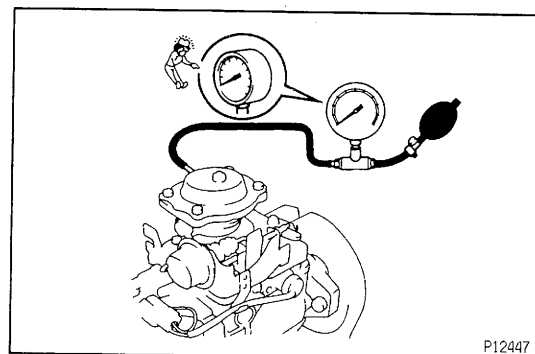

2. CHECK BOOST COMPENSATOR FOR AIR TIGHTNESS

- Apply 98 kPa (1.00 kgf/cm², 14.2 psi) of pressure to the boost compensator.
- Measure the time it takes for pressure to drop to 95 kPa (0.97 kgf/cm², 13.8 psi).

Pressure drop:

10 seconds or more

3. PRE-SET FULL LOAD INJECTION VOLUME

- Set the adjusting lever to maximum position.
- Apply 66.7 kPa (500 mmHg, 19.69 in.Hg) of vacuum to the PCS actuator.
- w/o BACS:
Apply 67 kPa (0.68 kgf/cm², 9.7 psi) of pressure to the boost compensator.
- w/ BACS:
Apply 116 kPa (1.17 kgf/cm², 16.6 psi) of pressure to the boost compensator.
- Measure the injection volume.

Item	Pump rpm	No. of measuring strokes	Injection volume of each cylinder cc (cu in.)
w/o BACS	1,800	200	15.4 - 15.8 (0.94 - 0.96)
w/ BACS	1,800	200	14.5 - 14.9 (0.88 - 0.91)

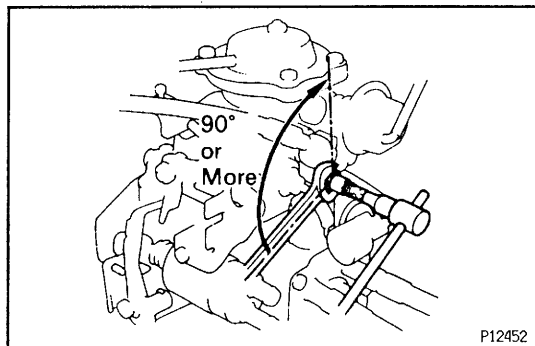

P12452

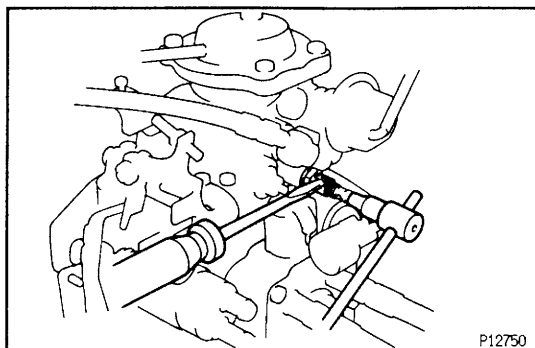

P12750

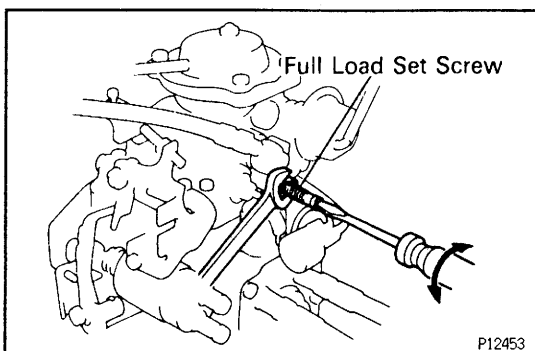

P12453

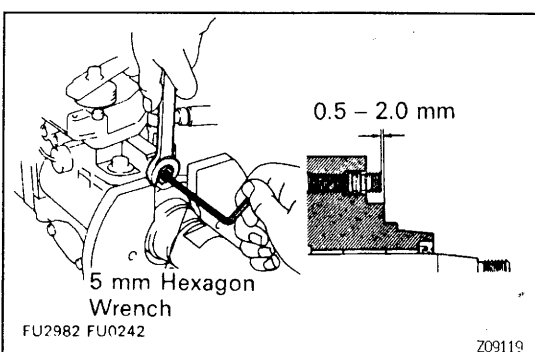

Z09119

- (f) Remove the collar seal as follows:
- Hold the full load set screw, and release the collar seal from the spot weld by turning the lock nut counterclockwise by 90° or more.

- Using a screwdriver, pry out the collar seal.

- (g) Adjust by turning the full load set screw.
HINT: The injection volume will increase about 3 cc (0.18 cu in.) with each 1/2 turn of the screw.

4. **w/o BACS:**
PRE—SETTING OF LOAD SENSING TIMER
Using a 5 mm hexagon wrench, adjust the protrusion of the governor shaft.
Protrusion:
0.5 – 2.0 mm (0.020 – 0.079 in.)

5. **PRE—SET MAXIMUM SPEED**
- Set the adjusting lever to maximum position.
 - Apply 66.7 kPa (500 mmHg, 19.69 in.Hg) of vacuum to the PCS actuator.
 - w/o BACS:
Apply 67 kPa (0.68 kgf/cm², 9.7 psi) of pressure to the boost compensator.

- w/ BACS:
Apply 116 kPa (1.17 kgf/cm², 16.6 psi) of pressure to the boost compensator.
- Measure the injection volume.

Pump rpm	No. of measuring strokes	Injection volume of each cylinder cc (cu in.)
2,300	200	5.2 – 7.2 (0.32 – 0.44)

V03726

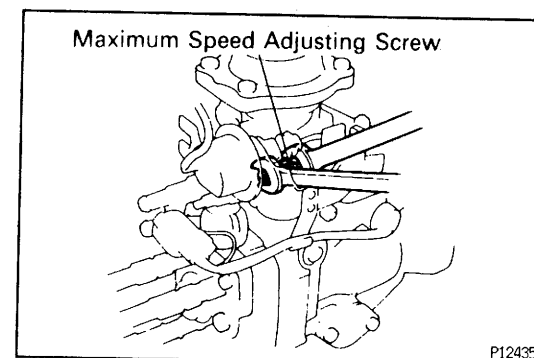

P12435

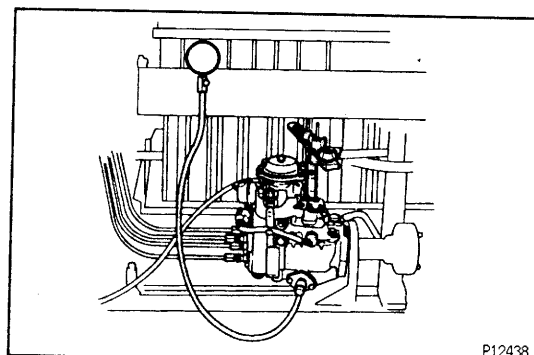

P12438

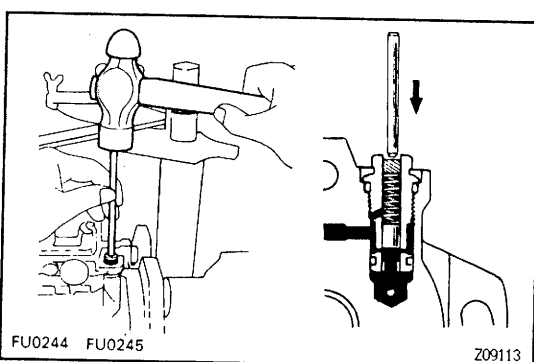

FU0244 FU0245

Z09113

- Remove the lock plate.
- Adjust the injection volume with the maximum speed adjusting screw.

6. ADJUST PUMP INNER PRESSURE

- Measure the pump inner pressure at the below listed rpm.

Pump rpm	Inner pressure kPa (kgf/cm ² , psi)
500	412 – 471 (4.2 – 4.8, 60 – 68)
2,000	785 – 843 (8.0 – 8.6, 114 – 122)

- If the pressure is low, adjust by lightly tapping the regulator valve piston while watching the pressure gauge.
HINT: If the pressure is too high or if the regulator valve was tapped in too far, the regulator valve must be replaced.

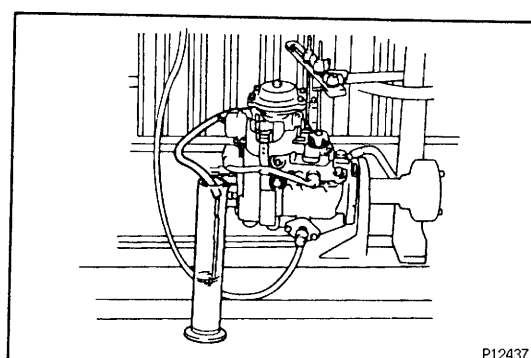

P12437

7. CHECK OVERFLOW VOLUME

Measure the overflow volume at the below listed rpm.

Pump rpm	Overflow volume cc/min. (cu in./min.)
500	720 – 1,150 (43.9 – 70.2)

HINT: Always use the overflow screw installed on the pump to be adjusted.

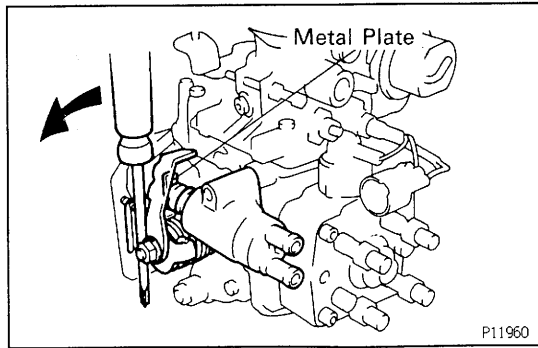

P11960

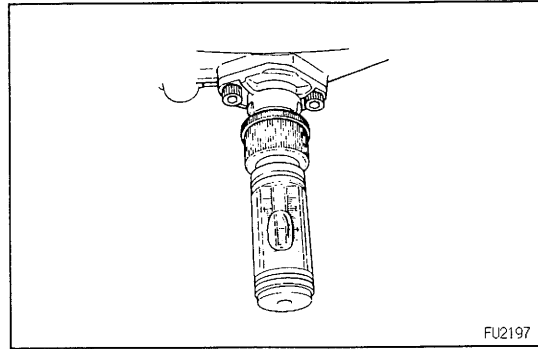

FU2197

**8. w/ ACSD:
RELEASE COLD STARTING SYSTEM FOR NEXT INSPECTIONS**

- (a) Using a screwdriver, turn the cold starting lever counterclockwise approx. 20°.
- (b) Put a metal plate (thickness of 8.5 – 10 mm (0.33 – 0.39 in.)) between the cold starting lever and thermo wax plunger.

HINT: Keep the cold starting system released until all measurements and adjustments are finished.

9. ADJUST TIMER

- (a) Set the timer measuring device at zero.
- (b) w/o BACS:
Apply 67 kPa (0.68 kgf/cm², 9.7 psi) of pressure to the boost compensator.
- (c) w/ BACS:
Apply 116 kPa (1.17 kgf/cm², 16.6 psi) of pressure to the boost compensator.
- (d) Measure the timer piston stroke at the below listed rpm.

Item	Pump rpm	Piston stroke mm (in.)
w/o BACS	600	0.7 – 1.5 (0.028 – 0.059)
	1,000	3.9 – 4.7 (0.154 – 0.185)
	1,800	8.3 – 9.1 (0.327 – 0.358)
	2,000	8.5 – 9.1 (0.335 – 0.358)
w/ BACS	750	0.6 – 1.4 (0.024 – 0.055)
	1,000	2.3 – 3.1 (0.091 – 0.122)
	1,800	6.7 – 7.5 (0.264 – 0.295)
	2,000	7.1 – 7.5 (0.280 – 0.295)

V03725

HINT: Check that the hysteresis is within 0.3 mm (0.012 in.).

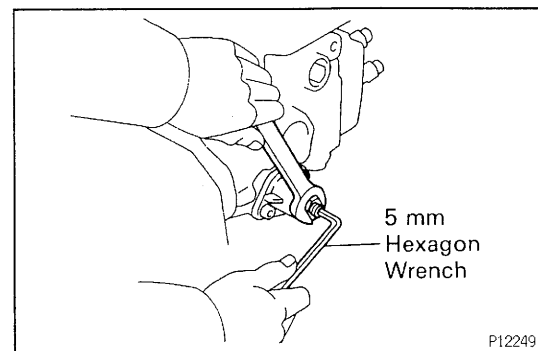

P12249

- (e) Using a 5 mm hexagon wrench, adjust by turning the timer adjusting screw.

HINT: Turn clockwise to reduce the stroke, turn counterclockwise to increase the stroke.

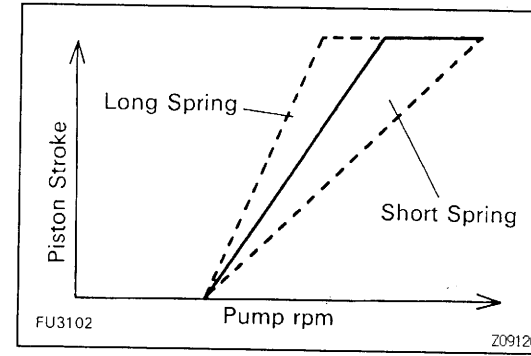

FU3102

Z09120

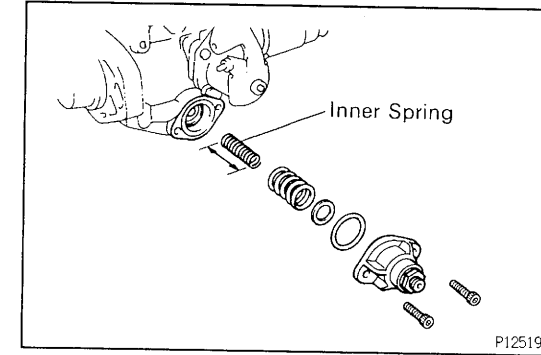

P12519

- (f) Check the timer stroke for characteristic tendency.

If tendency is not as specified, select and replace the inner spring.

Timer spring free length:

40.4 mm (1.59 in.)

39.5 mm (1.56 in.)

38.8 mm (1.53 in.)

38.2 mm (1.50 in.)

HINT: The timer stroke will increase with a long spring and decrease with a short spring.

10. ADJUST FULL LOAD INJECTION VOLUME

- (a) The adjusting lever angle for the adjustment below should be as shown in the illustration.

Adjusting lever angle:

A (Maximum speed side)	B (Idle speed side)
Plus 23.5 – 33.5°	Minus 12.5 – 22.5°

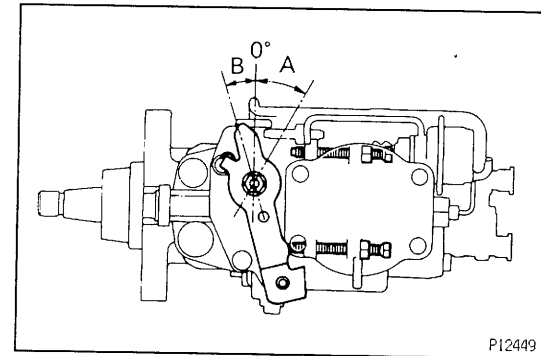

P12449

- (b) Apply 66.7 kPa (500 mmHg, 19.69 in.Hg) of vacuum to the PCS actuator.
- (c) w/o BACS:
Apply 67 kPa (0.68 kgf/cm², 9.7 psi) of pressure to the boost compensator.
- (d) w/ BACS:
Apply 116 kPa (1.17 kgf/cm², 16.6 psi) of pressure to the boost compensator.
- (e) Measure the full load injection volume.

Item	Adjusting lever angle	Pump rpm	No. of measuring strokes	Injection volume of each cylinder cc (cu in.)	Variation limit cc (cu in.)
w/o BACS	Plus 23.5 – 33.5°	1,800	200	15.4 – 15.8 (0.94 – 0.96)	0.7 (0.04)
w/ BACS	Plus 23.5 – 33.5°	1,800	200	14.5 – 14.9 (0.88 – 0.91)	0.7 (0.04)

V03727

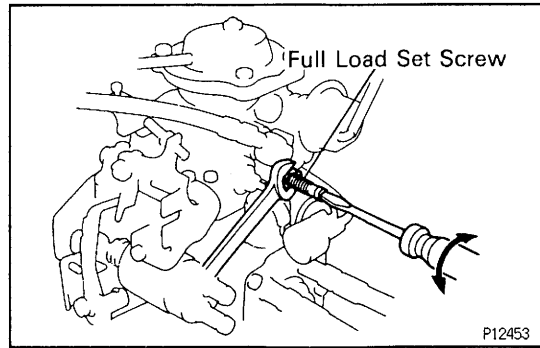

- (f) Adjust by turning the full load set screw.
 HINT: The injection volume will increase about 3 cc (0.18 cu in.) with each 1/2 turn of the screw.

- (g) Release the vacuum from the PCS actuator.
 (h) Measure the injection volume.

Item	Adjusting lever angle	Pump rpm	No. of measuring strokes	Injection volume of each cylinder cc (cu in.)
w/o BACS	Plus 23.5 – 33.5°	1,200	200	14.6 – 14.9 (0.89 – 0.91)
w/ BACS	Plus 23.5 – 33.5°	1,200	200	14.5 – 14.8 (0.88 – 0.90)

V03728

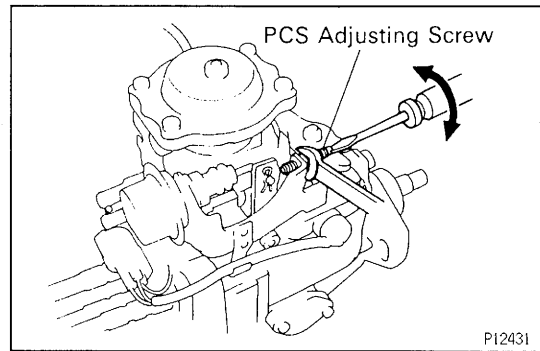

- (i) Adjust by turning the PCS adjusting screw.
 HINT: By screwing in the adjusting screw, the injection volume is increased; unscrewing the adjusting screw decreases the injection volume.

- (j) Apply 66.7 kPa (500 mmHg, 19.69 in.Hg) of vacuum to the PCS actuator, then check that the clearance between the PCS lever and adjusting screw is 3 mm (0.12 in.) or more.

11. ADJUST MAXIMUM SPEED

- (a) w/o BACS:
 Apply 67 kPa (0.68 kgf/cm², 9.7 psi) of pressure to the boost compensator.
- (b) w/ BACS:
 Apply 116 kPa (1.17 kgf/cm², 16.6 psi) of pressure to the boost compensator.
- (c) Apply 66.7 kPa (500 mmHg, 19.69 in.Hg) of vacuum to the PCS actuator.
- (d) Measure the injection volume at each pump rpm.

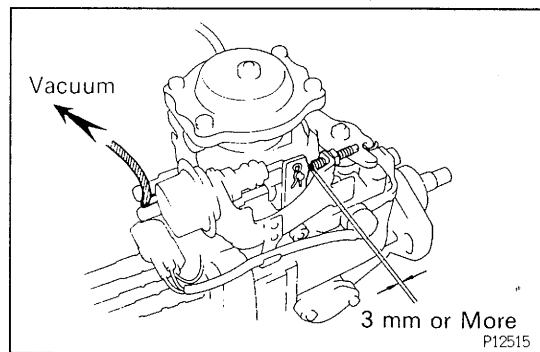

Item	Adjusting lever angle position	Pump rpm	No. of measuring strokes	Injection volume of each cylinder cc (cu in.)	Remarks
w/o BACS	Plus 23.5 – 33.5°	2,200	200	8.8 – 13.6 (0.54 – 0.83)	–
		2,300		5.2 – 7.2 (0.32 – 0.44)	Adjust
		2,450		3.0 (0.18) or less	–
w/ BACS	Plus 23.5 – 33.5°	2,200	200	7.6 – 12.4 (0.46 – 0.76)	–
		2,300		5.2 – 7.2 (0.32 – 0.44)	Adjust
		2,450		3.0 (0.18) or less	–

V03729

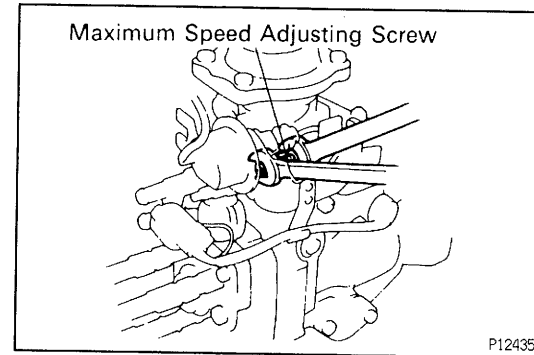

- (e) Adjust by turning the maximum speed adjusting screw.

12. CHECK INJECTION VOLUME

- (a) Apply 66.7 kPa (500 mmHg, 19.69 in.Hg) of vacuum to the PCS actuator.
- (b) Measure the injection volume at each pump rpm and boost pressure.

Item	Adjusting lever angle	Pump rpm	Boost pressure kPa (kg/cm ² , psi)	No. of measuring strokes	Injection volume of each cylinder cc (cu in.)	Variation limit cc (cu in.)	Remarks
w/o BACS	Plus 23.5° – 33.5°	100	0 (0, 0)	200	14.6 – 19.4 (0.89 – 11.8)	1.3 (0.08)	Volume during starting
		500	20 (0.20, 2.8)		13.0 – 13.8 (0.79 – 0.84)	–	–
		700	34 (0.34, 4.8)		14.9 – 16.1 (0.91 – 0.98)	–	–
		1,200	67 (0.68, 9.7)		16.6 – 17.8 (1.01 – 1.09)	0.7 (0.04)	–
		1,800	67 (0.68, 9.7)		15.4 – 15.8 (0.94 – 0.96)	0.7 (0.04)	Basic full-load injection volume
w/ BACS	Plus 23.5° – 33.5°	100	49 (0.50, 7.1)	200	14.6 – 19.4 (0.89 – 11.8)	1.3 (0.08)	Volume during starting
		500	65 (0.66, 9.4)		12.2 – 13.0 (0.74 – 0.79)	–	–
		700	77 (0.79, 11.2)		13.8 – 15.0 (0.84 – 0.92)	–	–
		1,200	116 (1.17, 16.6)		16.3 – 17.5 (0.99 – 1.07)	0.7 (0.04)	–
		1,800	116 (1.17, 16.6)		14.5 – 14.9 (0.88 – 0.91)	0.7 (0.04)	Basic full-load injection volume

V03730

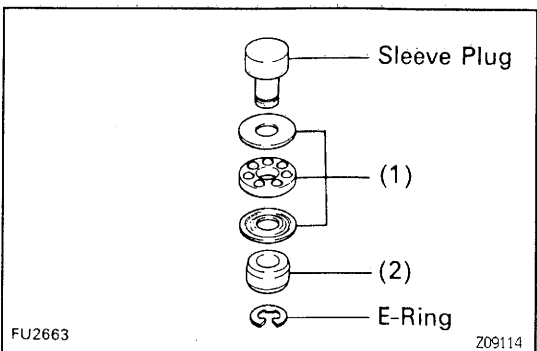
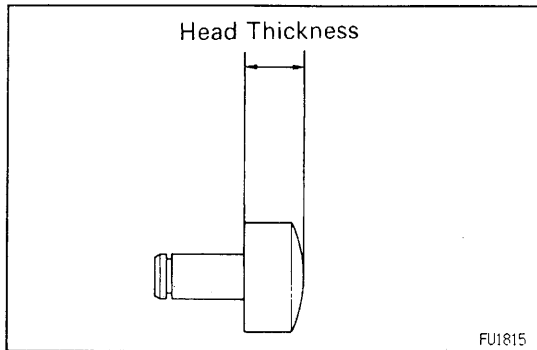
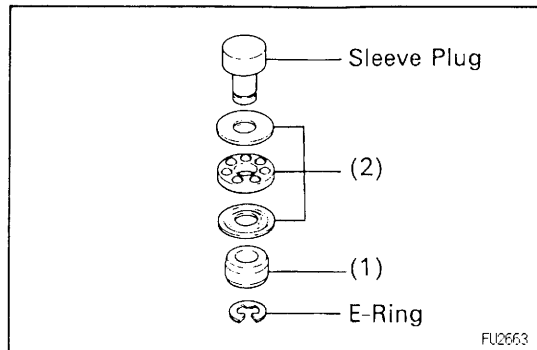
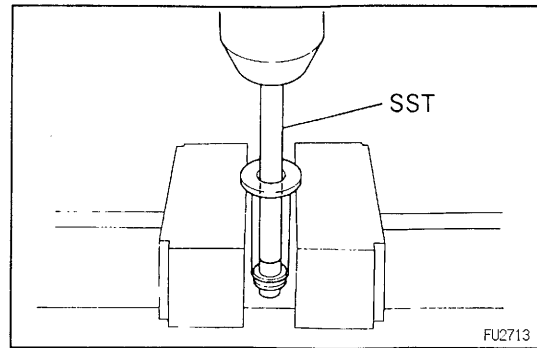

If the injection volume at 100 rpm is not as specified, replace the governor sleeve plug as follows:

- Using SST and a press, press out the sleeve plug assembly from the governor sleeve.
SST 09236-00101 (09237-00070)

- Remove the E-ring and following parts from the sleeve plug:
 - (1) Stop ring
 - (2) Bearing and 2 bearing retainers

- Measure the head thickness of the sleeve plug, and select a new sleeve plug.

Governor sleeve plug head thickness: mm (in.)

3.0 (0.118)	3.6 (0.142)	4.2 (0.165)
3.2 (0.126)	3.8 (0.150)	4.4 (0.173)
3.4 (0.134)	4.0 (0.157)	—

HINT: Lengthening the plug by 0.1 mm (0.004 in.) will decrease injection volume by 1.0 cc (0.06 cu in.). If the variation limit is greater than specified, replace the delivery valve.

- Install the following parts to the new sleeve plug with a new E-ring:
 - (1) Bearing and 2 retainers
 - (2) Stop ring

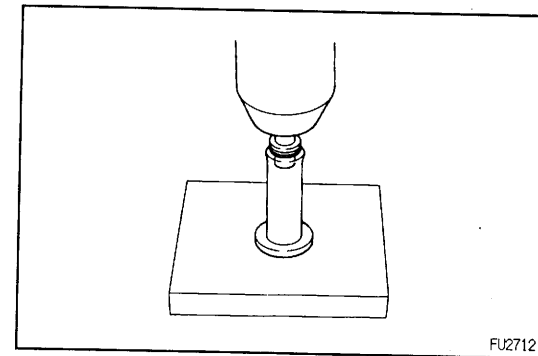

- Using a press, press in the sleeve plug assembly to the governor sleeve.

13. ADJUST FULL LOAD MINIMUM INJECTION VOLUME

- Set the adjusting lever to maximum position.
- Apply 66.7 kPa (500mmHg, 19.69 in.Hg) of vacuum to the PCS actuator.
- w/o BACS:
Release the pressure from the boost compensator.
- w/ BACS:
Apply 49 kPa (0.50 kgf/cm², 7.1 psi) of pressure to the boost compensator.
- Measure the injection volume.

Item	Adjusting lever angle	Pump rpm	Boost pressure kPa (kgf/cm ² , psi)	No. of measuring strokes	Injection volume of each cylinder cc (cu in.)
w/o BACS	Plus 23.5 – 33.5°	500	0 (0, 0)	200	11.9 – 12.5 (0.73 – 0.76)
w/ BACS	Plus 23.5 – 33.5°	500	49 (0.50, 7.1)	200	8.1 – 9.3 (0.49 – 0.57)

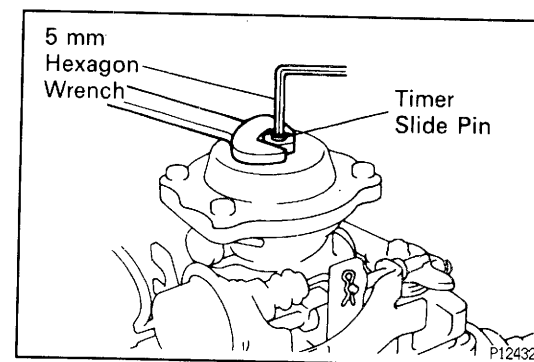

- Using a 5 mm hexagon wrench, adjust by turning the timer slide pin.

14. ADJUST BOOST COMPENSATOR

A. Adjust characteristic

- Apply 66.7 kPa (500 mmHg, 19.69 in.Hg) of vacuum to the PCS actuator.
- w/o BACS:
Apply 20 kPa (0.20 kgf/cm², 2.8 psi) of pressure to the boost compensator.

- (c) w/ BACS:
Apply 65 kPa (0.66 kgf/cm², 9.4 psi) of pressure to the boost compensator.
- (d) Measure the injection volume.

Item	Pump rpm	Boost pressure kPa (kgf/cm ² , psi)	No. of measuring strokes	Injection volume of each cylinder cc (cu in.)
w/o BACS	500	20 (0.20, 2.8)	200	13.0 – 13.8 (0.79 – 0.84)
w/ BACS	500	65 (0.66, 9.4)	200	12.2 – 13.0 (0.74 – 0.79)

V03732

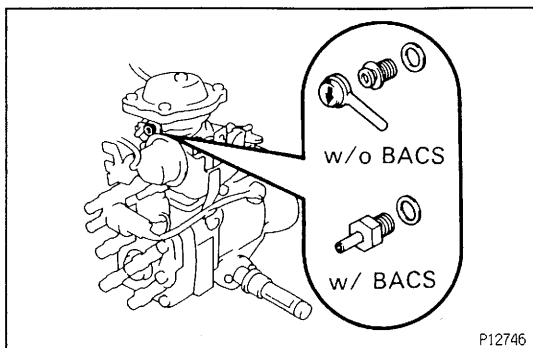

P12746

- (e) w/o BACS:
Remove the rubber cap.
- (f) Remove the overflow screw and gasket.

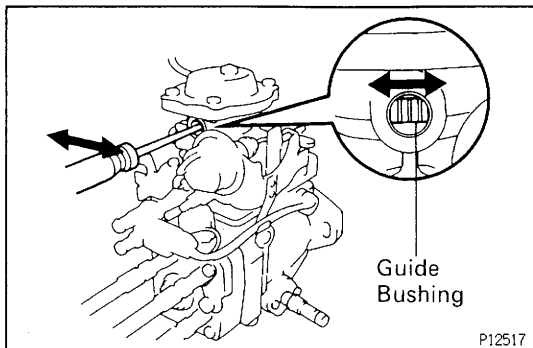

P12517

- (g) Using a screwdriver, adjust the injection volume by the guide bushing.
HINT: When the guide bushing is turned clockwise, as seen from above, the injection volume will increase.

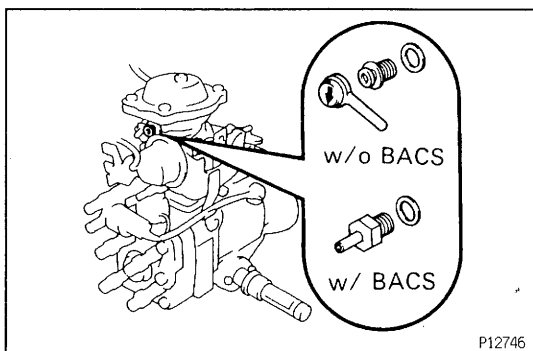

P12746

- (h) Install the overflow screw with a new gasket.
- (i) w/o BACS:
Install the rubber cap facing the arrow downward.

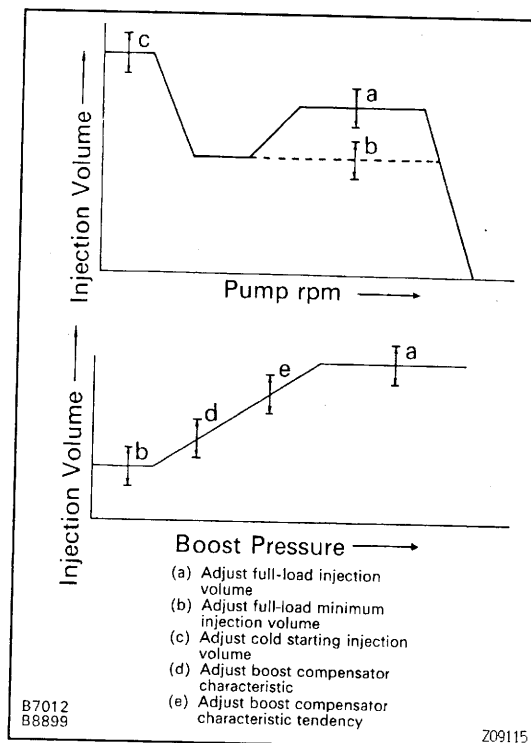

B7012
B8899

Z09115

B. Check for characteristic tendency

- (a) Apply 66.7 kPa (500 mmHg, 19.69 in.Hg) of vacuum to the PCS actuator.
- (b) Measure the injection volume for each set of pump rpm / boost pressure conditions listed in the table below.

Item	Pump rpm	Boost pressure kPa (kgf/cm ² , psi)	No. of measuring strokes	Injection volume of each cylinder cc (cu in.)
w/o BACS	1,800	87 (0.88, 12.5)	200	15.3 – 15.9 (0.93 – 0.97)
	1,800	67 (0.68, 9.7)	200	15.4 – 15.8 (0.94 – 0.96)
	700	34 (0.34, 4.8)	200	14.9 – 16.1 (0.91 – 0.98)
	500	20 (0.20, 2.8)	200	13.0 – 13.8 (0.79 – 0.84)
	500	0 (0, 0)	200	11.9 – 12.5 (0.73 – 0.76)
w/ BACS	1,800	136 (1.38, 19.6)	200	14.4 – 15.0 (0.88 – 0.92)
	1,800	116 (1.17, 16.6)	200	14.5 – 14.9 (0.88 – 0.91)
	700	77 (0.79, 11.2)	200	13.8 – 15.0 (0.84 – 0.92)
	500	65 (0.66, 9.4)	200	12.2 – 13.0 (0.74 – 0.79)
	500	0 (0, 0)	200	8.1 – 9.3 (0.49 – 0.57)

V03734

If not within standard value, check each sliding part of the boost compensator and check whether or not there is any oil.

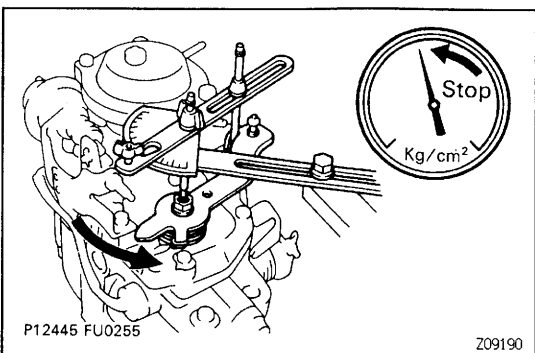
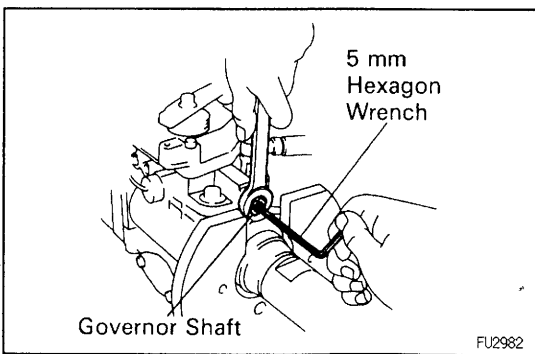
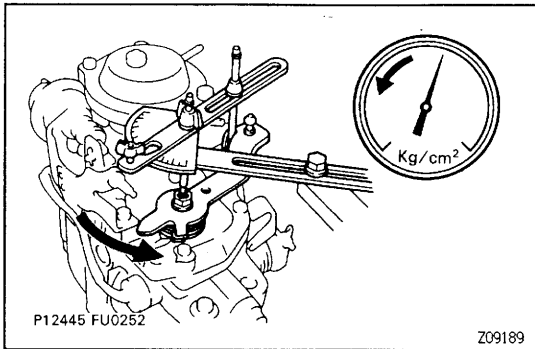
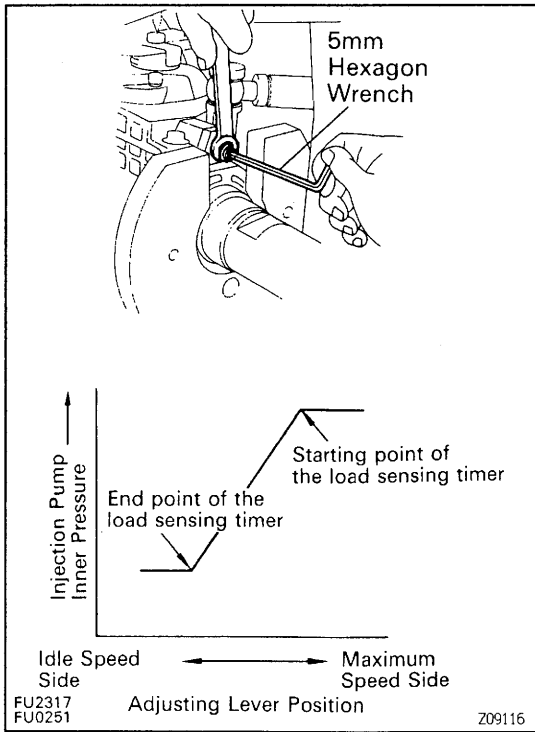

**15. w/o BACS:
ADJUST LOAD SENSING TIMER**

- (a) Using a 5 mm hexagon wrench, adjust the starting and end points of the load sensing timer by turning the governor shaft.
- (b) Set the adjusting lever to maximum position.
- (c) Apply 66.7 kPa (500 mmHg, 19.69 in.Hg) of vacuum to the PCS actuator.
- (d) Measure the injection volume.

Adjusting lever position	Pump rpm	No. of measuring strokes
Maximum speed side	1,000	200

- (e) Slowly move the adjusting lever from the maximum speed side to the idle speed side, and secure it at the point where the pump inner pressure begins to drop.
- (f) Measure the injection volume at the drop point (starting point).

Pump rpm	No. of measuring strokes	Injection volume of each cylinder cc (cu in.)
1,000	200	Measured value at step (b) minus 0.6 (0.04) ± 0.4 (0.02)

- (g) Using a 5 mm hexagon wrench, adjust the load sensing timer by turning the governor shaft, and perform the measurement again as specified.
HINT: The injection volume will increase approx. 3 cc (0.2 cu in.) with each 1/2 turn of the governor shaft.

- (h) Check the end point injection volume by slowly moving the adjusting lever from the maximum speed side to the idle speed side, and secure it at the point where the pump inner pressure stops dropping.

Pump rpm	No. of measuring strokes	Injection volume of each cylinder cc (cu in.)
1,000	200	10.2 – 10.6 (0.62 – 0.65)

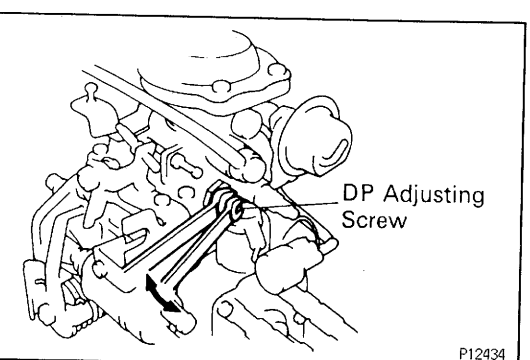
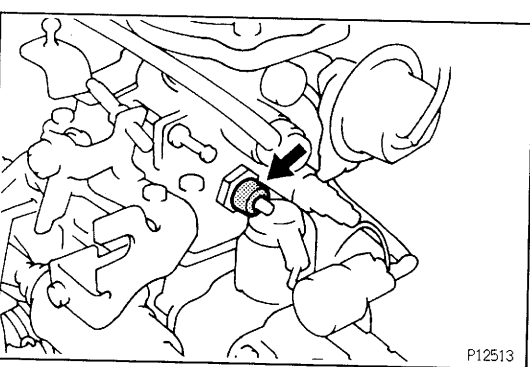
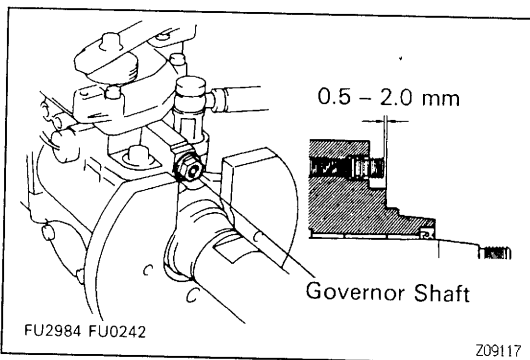
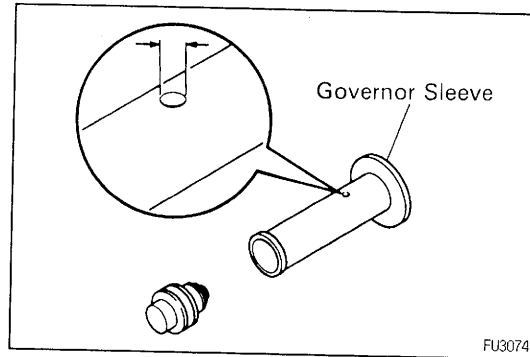
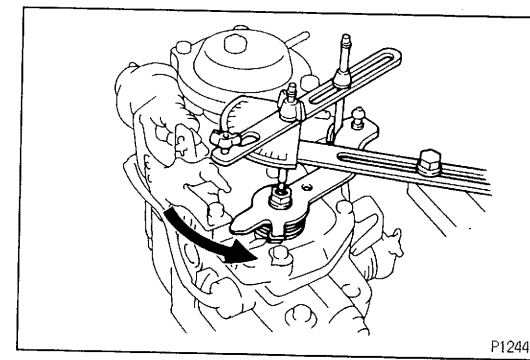

- (i) When the adjusting lever is moved slowly from the maximum speed side to the idle speed side, the timer stroke at the maximum retard angle (minimum timer piston stroke) should be as shown in the table below. (end point)

Pump rpm	Timer piston stroke mm (in.)
1,000	1.44 – 2.24 (0.057 – 0.088)

If the timer stroke is not as specified when the load sensing is at maximum retard angle, select a new governor sleeve.

Governor sleeve hole diameter:

- 0.75 mm (0.0295 in.) x 2 holes
- 0.80 mm (0.0315 in.) x 2 holes
- 0.85 mm (0.0335 in.) x 2 holes

HINT: A large hole diameter decreases the timer stroke and a smaller hole diameter increases the timer stroke.

- (j) Check the protrusion of the governor shaft.
Protrusion:
0.5 – 2.0 mm (0.020 – 0.079 in.)

16. ADJUST IDLE SPEED

- (a) Using pliers, remove the dash pot collar.

- (b) Fully loosen the dash pot adjusting screw.
- (c) Apply 66.7 kPa (500 mmHg, 19.69 in.) of vacuum to the PCS actuator.
- (d) w/o BACS:
Release the pressure from the boost compensator.
- (e) w/ BACS:
Apply 49 kPa (0.50 kgf/cm², 7.1 psi) of pressure to the boost compensator.

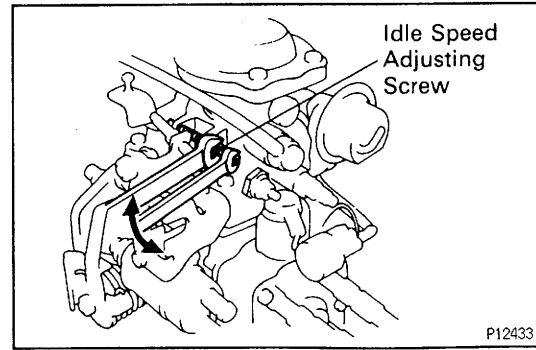

- (f) (Pre-Set Idle Speed)
Adjust injection volume by turning the idle speed adjusting screw.

Item	Pump rpm	Boost pressure kPa (kgf/cm ² , psi)	No. of measuring strokes	Injection volume of each cylinder cc (cu in.)
w/o BACS	1,000	0 (0, 0)	200	q = 1.7 – 2.1 (0.10 – 0.13)
w/ BACS	1,000	49 (0.50, 7.1)	200	q = 1.7 – 2.1 (0.10 – 0.13)

V03746

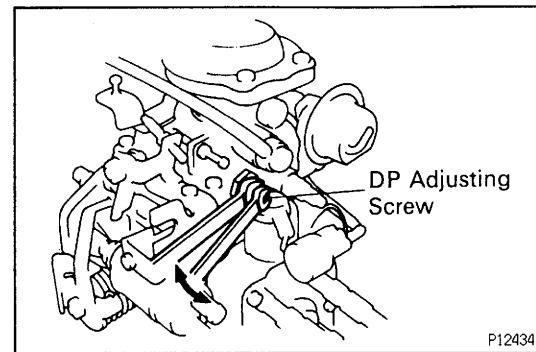

- (g) (Adjust DP Speed)
Adjust injection volume by turning the DP adjusting screw.
HINT: The stroke will decrease with turn to clockwise and increase with turn to counterclockwise.

Item	Pump rpm	Boost pressure kPa (kgf/cm ² , psi)	No. of measuring strokes	Injection volume of each cylinder cc (cu in.)
w/o BACS	1,000	0 (0, 0)	200	q plus 0.06 – 0.16 (0.004 – 0.010)
w/ BACS	1,000	49 (0.50, 7.1)	200	q plus 0.06 – 0.16 (0.004 – 0.010)

V03747

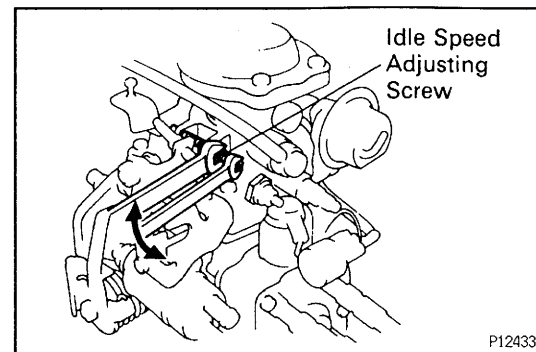

- (h) (Adjust Idle Speed)
Adjust injection volume by turning the idle speed adjusting screw.

Item	Adjusting lever angle	Pump rpm	Boost pressure kPa (kgf/cm ² , psi)	No. of measuring strokes	Injection volume of each cylinder cc (cu in.)	Variation limit cc (cu in.)
w/o BACS	Minus 12.5 – 22.5°	350	0 (0, 0)	200	3.0 – 4.0 (0.18 – 0.24)	0.5 (0.03)
w/ BACS	Minus 12.5 – 22.5°	350	49 (0.50, 7.1)	200	3.0 – 4.0 (0.18 – 0.24)	0.5 (0.03)

V03748

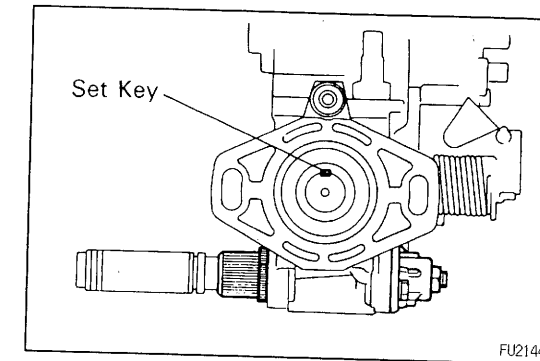

FU2144

17. w/ ACSD:
ADJUST COLD STARTING SYSTEM

- Remove the overflow screw and check the fuel temperature in the fuel pump.
Fuel temperature:
15 – 35°C (59 – 95°F)
- Set the set key of the pump drive shaft in a vertical or horizontal position.
- Set the scale of the timer measuring device to zero.
- Check the adjusting lever opening angle and consider this angle as zero.
- Remove the metal plate between the cold starting lever and thermo wax plunger.

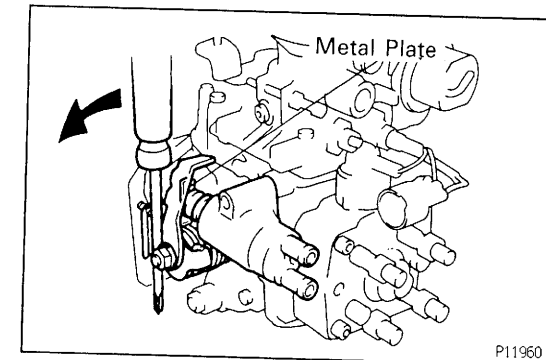

P11960

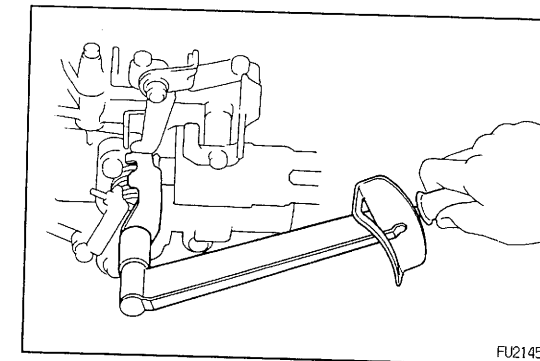

FU2145

- Torque the cold starting lever clockwise to approx. 4.9 N·m (50 kgf·cm, 43 in.-lbf) and keep the lever tightened for about 10 seconds. Then release the torque.

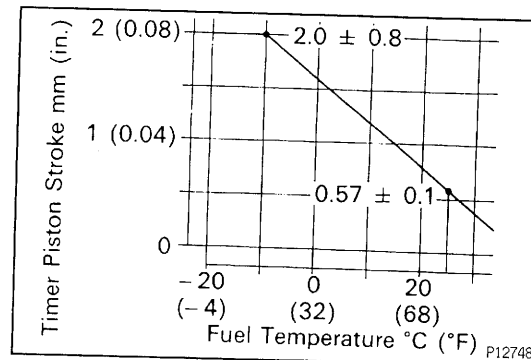

P12748

- (g) Measure the timer piston stroke.

Fuel temperature	Timer piston stroke mm (in.)
25°C (77°F)	0.47 – 0.67 (0.019 – 0.026)

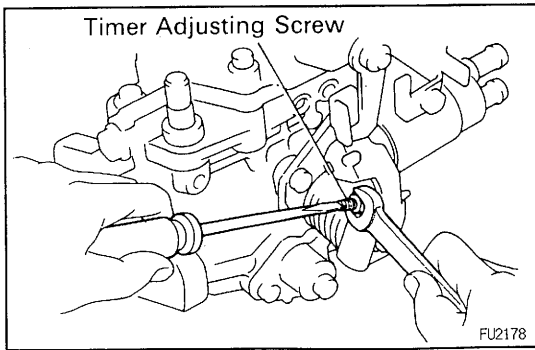

- (h) Adjust by turning the timer adjusting screw.
HINT: Screw in for stroke decrease.

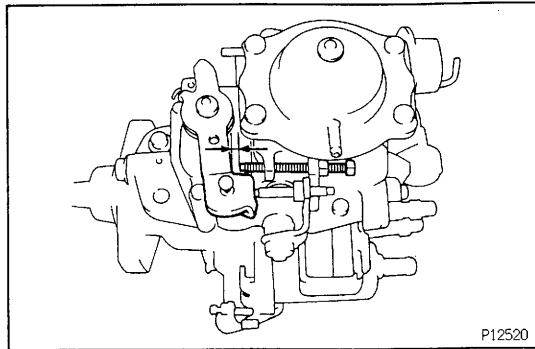

18. ADJUST FAST IDLE

- (a) Measure the clearance between the adjusting lever and idle speed adjusting screw.

Fuel temperature	Clearance
25°C (68°F)	5.5 mm (0.217 in.)
50°C (122°F)	0 mm (0 in.)

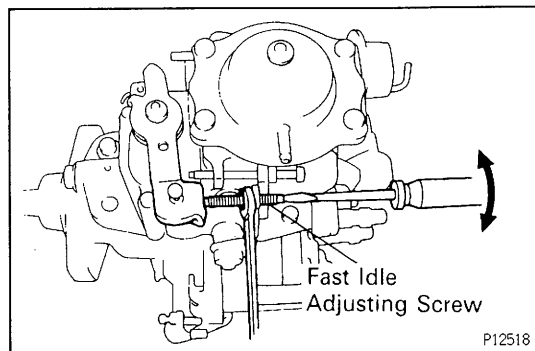

- (b) Adjust by turning the fast idle adjusting screw.

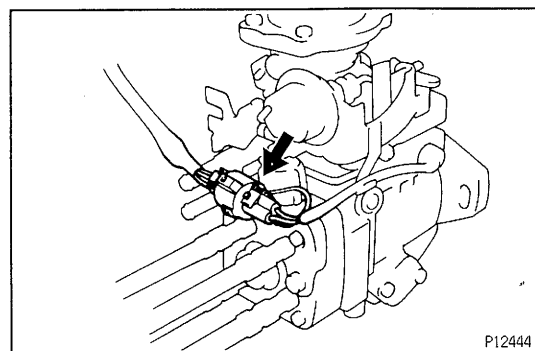

19. POST ADJUSTMENT CHECK

- (a) Check that injection stops when the fuel cut solenoid harness is removed.

Pump revolution:
100 rpm

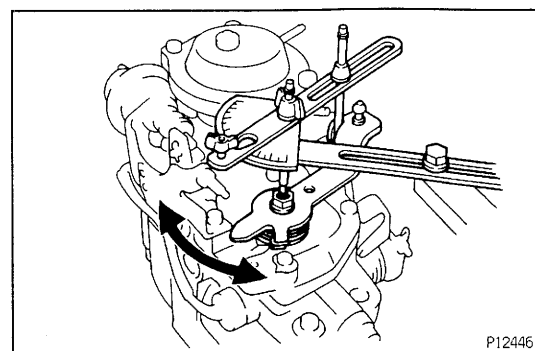

- (b) Check the adjusting lever movement.

Adjusting lever angle:
41 – 51°

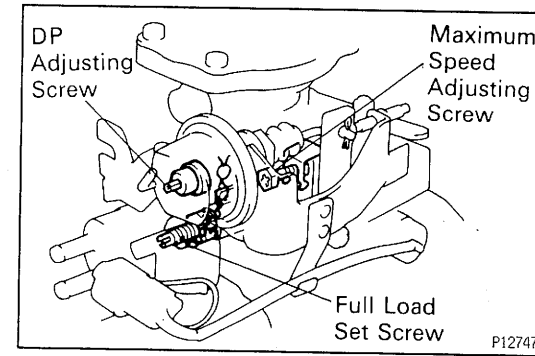

20. SEAL PARTS

- (a) Seal the full load set screw with new lead seal.
(b) Install the lock plate to the maximum speed adjusting screw.
(c) Seal the DP adjusting screw with new collar.

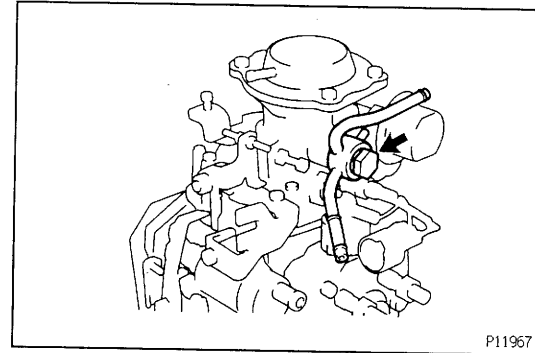

21. INSTALL FUEL PIPES

- (a) Install the fuel outlet pipe with 2 new gaskets and the union bolt.

Torque: 25 N·m (250 kgf·cm, 18 ft·lbf)

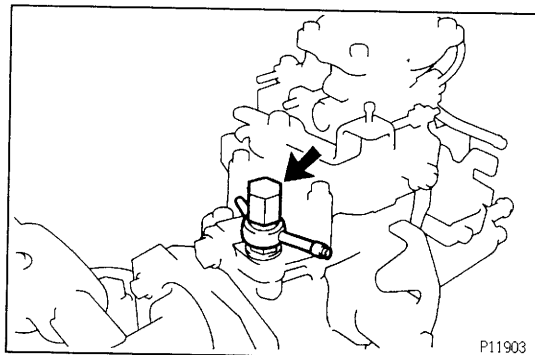

- (b) Install the fuel inlet pipe with 2 new gaskets and the cap nut.

Torque: 25 N·m (250 kgf·cm, 18 ft·lbf)

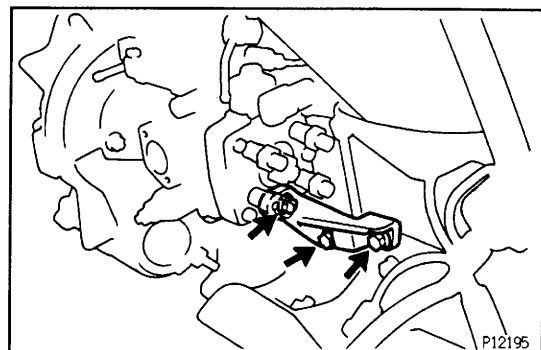
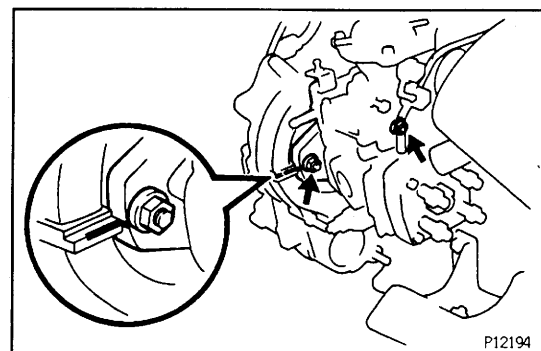
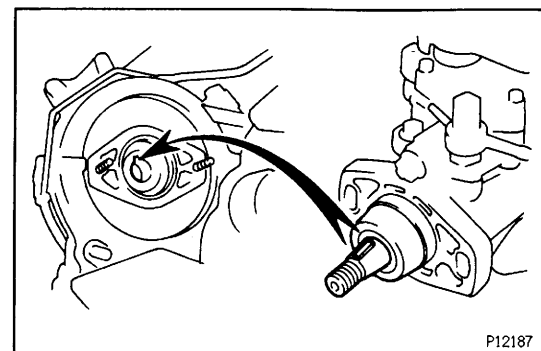
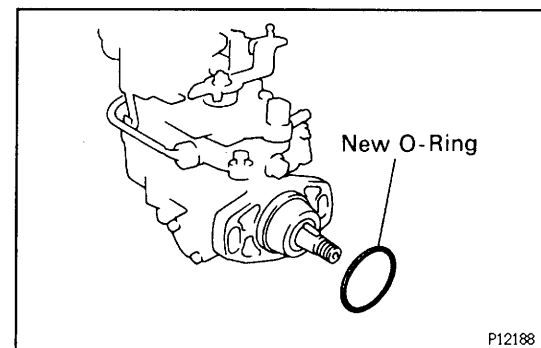

INJECTION PUMP INSTALLATION

EG218-01

(See Components for Removal and Installation)

1. INSTALL INJECTION PUMP

NOTICE: Do not put the injection pump at an angle more than 45° from the horizontal.

- (a) Install a new O—ring to the pump.
- (b) Apply a light coat of engine oil on the O—ring.
- (c) Align the set key on the drive shaft and groove of the injection pump drive gear.
- (d) Align the period lines (or matchmarks) of the injection pump and timing belt case.
- (e) Install the 2 nuts holding the injection pump to the timing gear case.
Torque: 21 N·m (210 kgf·cm, 15 ft·lbf)
- (f) Install the injection pump stay with the 3 bolts.
Torque:
32 N·m (330 kgf·cm, 24 ft·lbf)
for injection pump side
Torque:
32 N·m (330 kgf·cm, 24 ft·lbf)
for cylinder block side
NOTICE: Before tightening to the standard torque, check whether the pump stay is up against the injection pump. If there is a gap, loosen the bolts joining the pump stay to the cylinder block and set the pump stay against the injection pump.

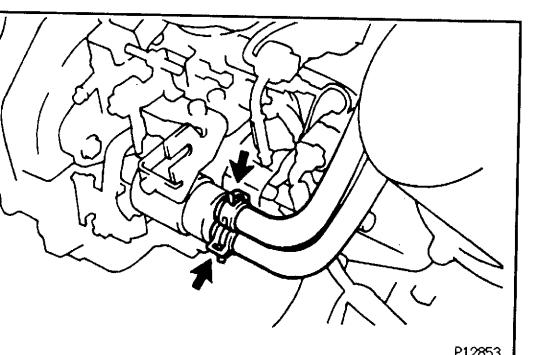
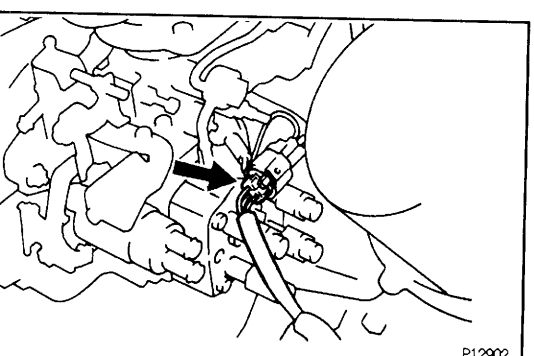
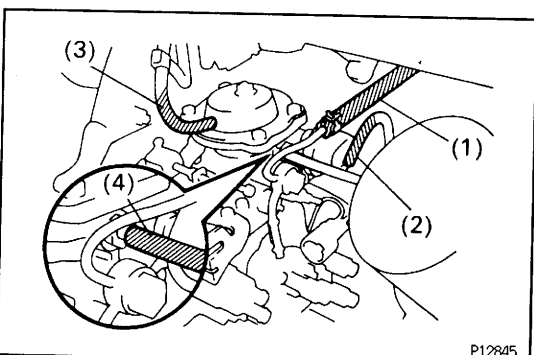
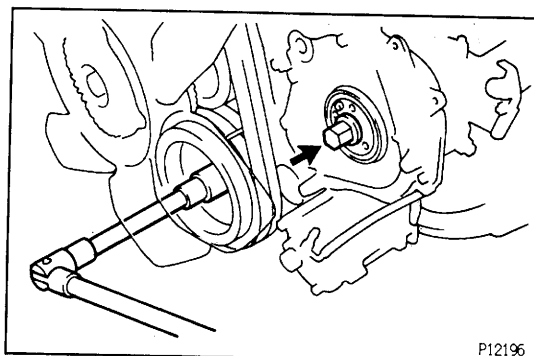
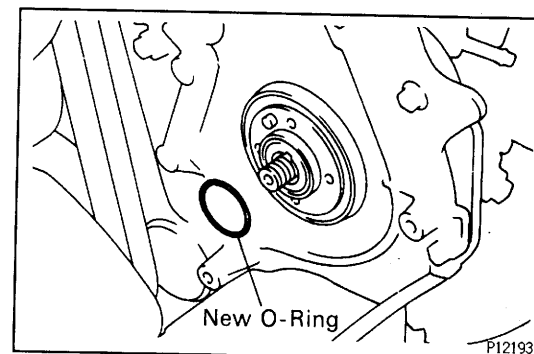

- (g) Install a new O—ring to the injection pump drive gear.
- (h) Install the injection pump drive gear set nut.
- (i) Hold the crankshaft pulley, and torque the set nut.
Torque: 64 N·m (650 kgf·cm, 47 ft·lbf)
- (j) Check the thrust clearance of the injection pump drive shaft. (See step 4 on page EG—55)
- (k) Connect the following hoses:
 - (1) Fuel hose
 - (2) PCS vacuum hose
 - (3) Boost compensator hose
 - (4) w/ BACS:
BACS vacuum hose
- (l) Connect the injection pump connector.
- (m) w/ ACSD:
Connect the 2 water bypass hoses to the thermo wax.

2. **INSTALL NO.2 CAMSHAFT TIMING PULLEY**
(See step 4 on page EG-37)
3. **INSTALL TIMING BELT**
(See steps 5 to 11 on pages EG-37 to 39)
4. **CHECK INJECTION TIMING** (See page EG-23)
5. **w/ A/C:**
CONNECT A/C IDLE-UP VACUUM HOSE

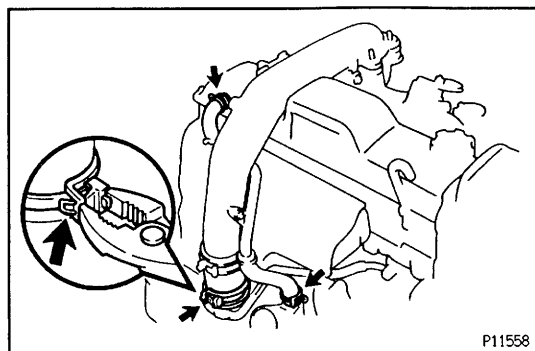
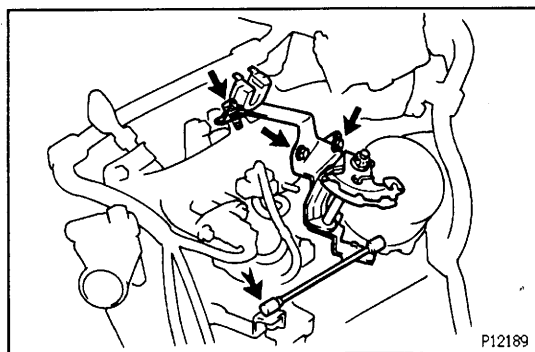
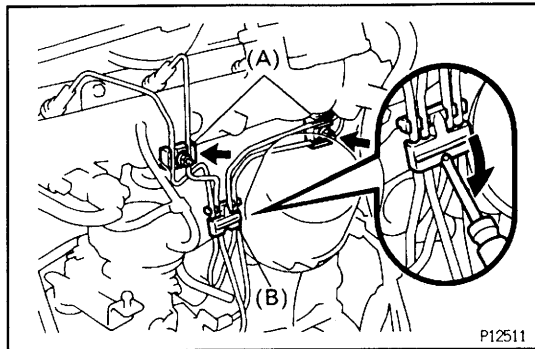
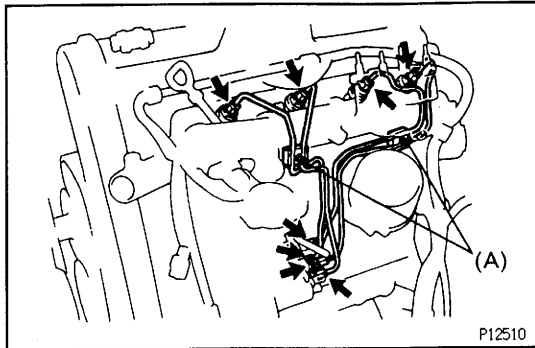

6. **INSTALL INJECTION PIPES**
 - (a) Temporarily install the 4 injection pipes and 2 clamps (A).
 - (b) Install the 2 nuts holding the clamps (A) to the intake manifold.
Torque: 6 N·m (65 kgf·cm, 56 in·lbf)
 - (c) Using a screwdriver, attach the clamp (B).
 - (d) Tighten the 8 union nuts.
Torque: 15 N·m (150 kgf·cm, 11 ft·lbf)
7. **INSTALL ACCELERATOR CABLE BRACKET AND LINK**
 - (a) Install the accelerator cable bracket and link with the 3 bolts.
 - (b) Connect the accelerator link to the injection pump.
8. **INSTALL INTAKE PIPE**
 - (a) Place a new gasket on the intake manifold.
 - (b) Connect the air hose and install the intake pipe.
 - (c) Press the clamp lock together with pliers and press down the tip of the lock plate. Carefully let the lock spread apart.
Take care not to let the pliers slip.
 - (d) Connect the 2 PCV hoses.

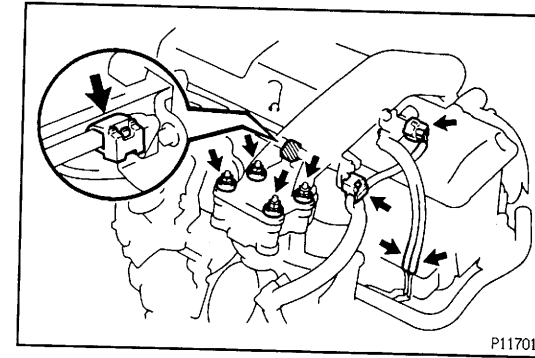

- (e) Install the 4 seal washers and nuts.
Torque: 12 N·m (120 kgf·cm, 9 ft·lbf)
 - (f) Connect the 2 wire harness clamps.
 - (g) Connect the VSV connector and 2 vacuum hoses.
9. **w/ ACSD:**
FILL WITH ENGINE COOLANT
 10. **START ENGINE AND CHECK FOR FUEL LEAKAGE**

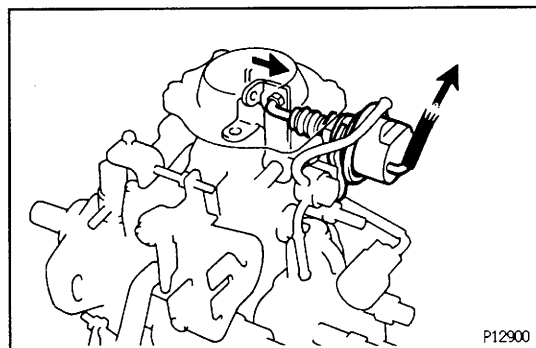

POWER CONTROL SYSTEM ON-VEHICLE INSPECTION

EG34C-01

INSPECT POWER CONTROL SYSTEM (PCS)

- (a) Start the engine.
- (b) Depress the clutch pedal and check the operation of the actuator at each shift position.

Standard:

Shift to 1st or Reverse ... Actuator not operating

Shifting to other positions ... Actuator operates

EG34D-01

POWER CONTROL SYSTEM (PCS) COMPONENTS INSPECTION

1. INSPECT PCS VSV

LOCATION: Behind the intake pipe.

A. Inspect VSV for open circuit

Using an ohmmeter, check that there is continuity between the terminals.

Resistance (Cold):

38.5 – 44.5 Ω

If there is no continuity, replace the VSV.

B. Inspect VSV for ground

Using an ohmmeter, check that there is no continuity between each terminal and the body.

If there is continuity, replace the VSV.

C. Inspect VSV operation

- (a) Check that air flows from pipe E to the filter.

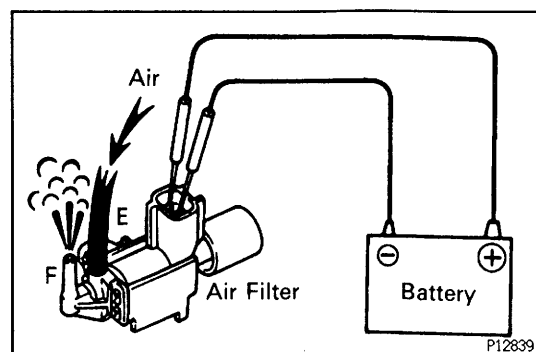
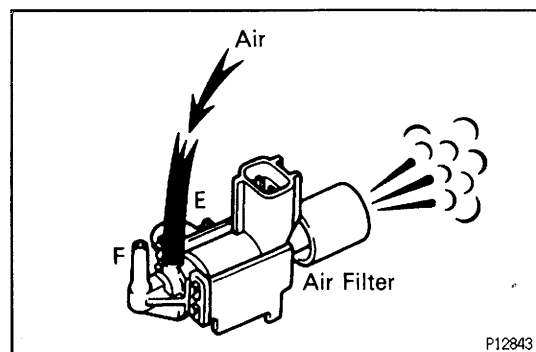
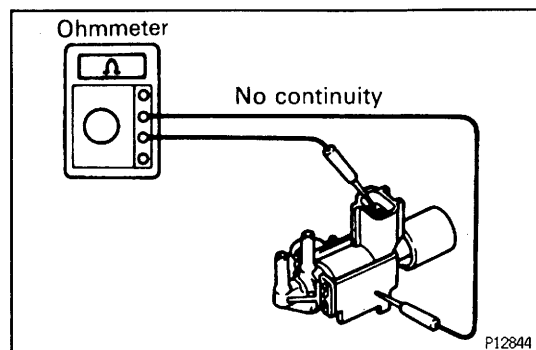
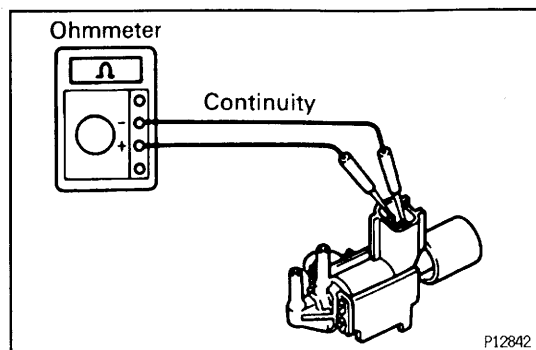

- (b) Apply battery voltage across the terminals.

- (c) Check that air flows from pipe E to F.

If operation is not as specified, replace the VSV.

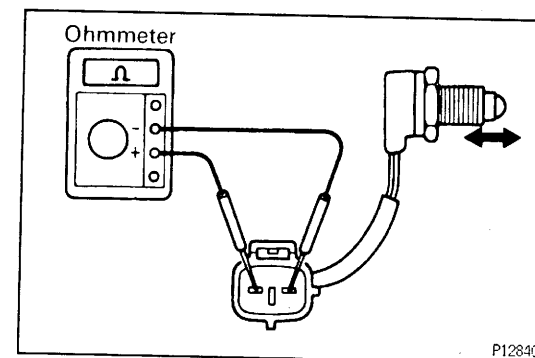

2. INSPECT SHIFT POSITION SWITCH

LOCATION: RH side of the transmission.

- (a) Check that there is no continuity between terminals when the switch is pushed (shift position 1st or reverse).

- (b) Check that there is continuity between terminals when switch is free (shift position others).

If continuity is not as specified, replace the switch.

SERVICE SPECIFICATIONS

SERVICE DATA

EG34E-01

Fuel heater	Resistance	at 20°C (68°F)	1.4 — 2.0 Ω
Injection nozzles	Nozzle type		DN0PD619
	Nozzle opening pressure	New nozzle	14,808 — 15,593 kPa (151 — 159 kgf/cm ² , 2,148 — 2,261 psi)
		Reused nozzle	14,710 — 15,593 kPa (150 — 159 kgf/cm ² , 2,133 — 2,261 psi)
	Adjusting shim thickness		0.900 mm (0.0354 in.) 0.925 mm (0.0364 in.) 0.950 mm (0.0374 in.) 0.975 mm (0.0384 in.) 1.000 mm (0.0394 in.) 1.025 mm (0.0404 in.) 1.050 mm (0.0413 in.) 1.075 mm (0.0423 in.) 1.100 mm (0.0433 in.) 1.125 mm (0.0443 in.) 1.150 mm (0.0453 in.) 1.175 mm (0.0463 in.) 1.200 mm (0.0472 in.) 1.225 mm (0.0482 in.) 1.250 mm (0.0492 in.) 1.275 mm (0.0502 in.) 1.300 mm (0.0512 in.) 1.325 mm (0.0522 in.) 1.350 mm (0.0531 in.) 1.375 mm (0.0541 in.) 1.400 mm (0.0551 in.) 1.425 mm (0.0561 in.) 1.450 mm (0.0571 in.) 1.475 mm (0.0581 in.) 1.500 mm (0.0591 in.) 1.525 mm (0.0600 in.) 1.550 mm (0.0610 in.) 1.575 mm (0.0620 in.) 1.600 mm (0.0630 in.) 1.625 mm (0.0640 in.) 1.650 mm (0.0650 in.) 1.675 mm (0.0659 in.) 1.700 mm (0.0669 in.) 1.725 mm (0.0679 in.) 1.750 mm (0.0689 in.) 1.775 mm (0.0699 in.)

Injection nozzles	Adjusting shim thickness		1.800 mm (0.0709 in.) 1.825 mm (0.0719 in.) 1.850 mm (0.0728 in.) 1.875 mm (0.0738 in.) 1.900 mm (0.0748 in.) 1.925 mm (0.0758 in.) 1.950 mm (0.0768 in.)
Injection pump	Part No.	w/o BACS	22100-67040
		w/ BACS	22100-67050
	Direction of rotation		Clockwise as seen from drive side
	Injection order		1 — 3 — 4 — 2 (A — B — C — D)
	Roller height variation		0.02 mm (0.0008 in.)
	Plunger spring squareness		2.0 mm (0.079 in.)
	Spring free length		
	Delivery valve spring		24.4 mm (0.961 in.)
	Plunger spring		30.0 mm (1.181 in.)
	Coupling spring		15.5 mm (0.610 in.)
	Boost compensator spring	w/o BACS	19.4 mm (0.764 in.)
		w/ BACS	19.3 mm (0.760 in.)
	Pickup sensor resistance		650 — 970 Ω
	Timer adjusting screw protrusion pre-setting		7.5 — 8.0 mm (0.295 — 0.315 in.)
	Plunger spring shim thickness		0.5 mm (0.020 in.) 0.8 mm (0.031 in.) 1.0 mm (0.039 in.) 1.2 mm (0.047 in.) 1.5 mm (0.059 in.) 1.8 mm (0.071 in.) 2.0 mm (0.079 in.) 1.9 mm (0.075 in.) 2.0 mm (0.079 in.) 2.1 mm (0.083 in.) 2.2 mm (0.087 in.) 2.3 mm (0.091 in.) 2.4 mm (0.094 in.) 2.5 mm (0.098 in.) 2.6 mm (0.102 in.) 2.7 mm (0.106 in.) 2.8 mm (0.110 in.) 2.9 mm (0.114 in.)
	Plunger adjusting shim thickness		
	Flyweight holder thrust clearance		0.15 — 0.35 mm (0.0059 — 0.0138 in.)
	Governor shaft protrusion		0.5 — 2.0 mm (0.020 — 0.079 in.)
	Governor gear adjusting washer thickness		1.05 mm (0.0413 in.) 1.25 mm (0.0492 in.) 1.45 mm (0.0571 in.) 1.65 mm (0.0650 in.) 1.85 mm (0.0728 in.)

Preparations of pump tester	Test nozzle type Test nozzle opening pressure		DN12SD12 14,220 – 15,200 kPa (145 – 155 kgf/cm ² , 2,062 – 2,205 psi)			
	Injection pipe Outer diameter Inner diameter Length Minimum bending radius Fuel temperature Fuel feeding pressure Fuel cut solenoid voltage		6.0 mm (0.236 in.) 2.0 mm (0.079 in.) 840 mm (33.07 in.) 25 mm (0.98 in.) or more 40 – 45°C 20 kPa (0.2 kgf/cm ² , 2.8 psi) 12 V			
Full load injection volume pre-setting	Item	Adjusting lever position	Pump rpm	No. of measuring strokes	Injection volume of each cylinder cc (cu in.)	
	w/o BACS	Maximum speed side	1,800	200	15.4 – 15.8 (0.94 – 0.96)	
	w/ BACS	Maximum speed side	1,800	200	14.5 – 14.9 (0.88 – 0.91)	
Maximum speed pre-setting		Adjusting lever position	Pump rpm	No. of measuring strokes	Injection volume of each cylinder cc (cu in.)	
		Maximum speed side	2,300	200	5.2 – 7.2 (0.32 – 0.44)	
Pump inner pressure		Pump rpm	Inner pressure kPa (kgf/cm ² , psi)			
		500	412 – 471 (4.2 – 4.8, 60 – 68)			
		2,000	785 – 843 (8.0 – 8.6, 114 – 122)			
Overflow volume		Pump rpm	Overflow volume cc/min. (cc in./min.)			
		500	720 – 1,150 (43.9 – 70.2)			
Automatic timer	Item	Pump rpm	Piston stroke mm (in.)			
			w/o BACS			
				600	0.7 – 1.5 (0.028 – 0.059)	
				1,000	3.9 – 4.7 (0.154 – 0.185)	
				1,800	8.3 – 9.1 (0.327 – 0.358)	
				2,000	8.5 – 9.1 (0.335 – 0.358)	
				750	0.6 – 1.4 (0.024 – 0.055)	
				1,000	2.3 – 3.1 (0.091 – 0.122)	
				1,800	6.7 – 7.5 (0.264 – 0.295)	
				2,000	7.1 – 7.5 (0.280 – 0.295)	
Full load injection volume	Item	Adjusting lever angle	Pump rpm	No. of measuring strokes	Injection volume of each cylinder cc (cu in.)	Variation limit cc (cu in.)
	w/o BACS	Plus 23.5 – 33.5°	1,800	200	15.4 – 15.8 (0.94 – 0.96)	0.7 (0.04)
	w/ BACS	Plus 23.5 – 33.5°	1,800	200	14.5 – 14.9 (0.88 – 0.91)	0.7 (0.04)

V03934

Maximum speed	Item	Adjusting lever angle	Pump rpm	No. of measuring strokes	Injection volume of each cylinder cc (cu in.)			
					w/o BACS			
					Plus 23.5 – 33.5°			
	w/ BACS		Plus 23.5 – 33.5°					
			2,200	200	8.8 – 13.6 (0.54 – 0.83)			
			2,300	200	5.2 – 7.2 (0.32 – 0.44)			
		2,450	200	3.0 (0.18) or less				
		2,200	200	7.6 – 12.4 (0.46 – 0.76)				
		2,300	200	5.2 – 7.2 (0.32 – 0.44)				
		2,450	200	3.0 (0.18) or less				
Injection volume	Item	Adjusting lever angle	Pump rpm	Boost pressure kPa (kgf/cm ² , psi)	No. of measuring strokes	Injection volume of each cylinder cc (cu in.)		Variation limit cc (cu in.)
						w/o BACS		
			100	0 (0, 0)	200	14.6 – 19.4 (0.89 – 11.8)		1.3 (0.08)
			500	20 (0.20, 2.8)		13.0 – 13.8 (0.79 – 0.84)		
			700	34 (0.34, 4.8)		14.9 – 16.1 (0.91 – 0.98)		
			1,200	67 (0.68, 9.7)		16.6 – 17.8 (1.01 – 1.09)		
			1,800	67 (0.68, 9.7)		15.4 – 15.8 (0.94 – 0.96)		
			100	49 (0.50, 7.1)	200	14.6 – 19.4 (0.89 – 11.8)		1.3 (0.08)
			500	65 (0.66, 9.4)		12.2 – 13.0 (0.74 – 0.79)		
			700	77 (0.79, 11.2)		13.8 – 15.0 (0.84 – 0.92)		
			1,200	116 (1.17, 16.6)		16.3 – 17.5 (0.99 – 1.07)		
			1,800	116 (1.17, 16.6)		14.5 – 14.9 (0.88 – 0.91)		
	Governor sleeve plug head thickness				3.0 mm (0.118 in.) 3.2 mm (0.126 in.) 3.4 mm (0.134 in.) 3.6 mm (0.142 in.) 3.8 mm (0.150 in.) 4.0 mm (0.157 in.) 4.2 mm (0.165 in.) 4.4 mm (0.173 in.)			
	Full-load minimum injection volume	Item	Adjusting lever angle	Pump rpm	Boost pressure kPa (kgf/cm ² , psi)	No. of measuring strokes	Injection volume of each cylinder cc (cu in.)	
		w/o ABCS	Plus 23.5 – 33.5°	500	0 (0, 0)	200	11.9 – 12.5 (0.73 – 0.76)	
	w/ BACS	Plus 23.5 – 33.5°	500	49 (0.50, 7.1)	200	8.1 – 9.3 (0.49 – 0.57)		
Boost compensator characteristic	Item	Pump rpm	Boost pressure kPa (kgf/cm ² , psi)		No. of measuring strokes	Injection volume of each cylinder cc (cu in.)		
	w/o BACS	500	20 (0.20, 2.8)		200	13.0 – 13.8 (0.79 – 0.84)		
	w/ BACS	500	65 (0.66, 9.4)		200	12.2 – 13.0 (0.74 – 0.79)		

V03935

Boost compensator characteristic tendency	Item	Pump rpm	Boost pressure kPa (kgf/cm ² , psi)	No. of measuring strokes	Injection volume of each cylinder cc (cu in.)
	w/o BACS	1,800	87 (0.88, 12.5)	200	15.3 – 15.9 (0.93 – 0.97)
		1,800	67 (0.68, 9.7)	200	15.4 – 15.8 (0.94 – 0.96)
		700	34 (0.34, 4.8)	200	14.9 – 16.1 (0.91 – 0.98)
		500	20 (0.20, 2.8)	200	13.0 – 13.8 (0.79 – 0.84)
		500	0 (0, 0)	200	11.9 – 12.5 (0.73 – 0.76)
	w/ BACS	1,800	136 (1.38, 19.6)	200	14.4 – 15.0 (0.88 – 0.92)
		1,800	116 (1.17, 16.6)	200	14.5 – 14.9 (0.88 – 0.91)
		700	77 (0.79, 11.2)	200	13.8 – 15.0 (0.84 – 0.92)
		500	65 (0.66, 9.4)	200	12.2 – 13.0 (0.74 – 0.79)
500		0 (0, 0)	200	8.1 – 9.3 (0.49 – 0.57)	

Load sensing timer (w/o BACS only)	Pump rpm	No. of measuring strokes	Injection volume of each cylinder cc (cu in.)	Remark
	1,000	200	Measured value at step (b) minus 0.6 (0.04) ± 0.4 (0.02)	Set to starting point
	1,000	200	10.2 – 10.6 (0.62 – 0.65)	Check ending point
	Pump rpm	Timer piston stroke mm (in.)		
1,000	1.44 – 2.24 (0.057 – 0.088)			

Pre-set idle speed	Item	Pump rpm	Boost pressure kPa (kgf/cm ² , psi)	No. of measuring strokes	Injection volume of each cylinder cc (cu in.)
	w/o BACS	1,000	0 (0, 0)	200	q = 1.7 – 2.1 (0.10 – 0.13)
	w/ BACS	1,000	49 (0.50, 7.1)	200	q = 1.7 – 2.1 (0.10 – 0.13)

DP speed	Item	Pump rpm	Boost pressure kPa (kgf/cm ² , psi)	No. of measuring strokes	Injection volume of each cylinder cc (cu in.)
	w/o BACS	1,000	0 (0, 0)	200	q plus 0.06 – 0.16 (0.004 – 0.010)
	w/ BACS	1,000	49 (0.50, 7.1)	200	q plus 0.06 – 0.16 (0.004 – 0.010)

Idle speed	Item	Adjusting lever angle	Pump rpm	Boost pressure kPa (kgf/cm ² , psi)	No. of measuring strokes	Injection volume of each cylinder cc (cu in.)	Variation cc (cu in.)
	w/o BACS	Minus 12.5 – 22.5°	350	0 (0, 0)	200	3.0 – 4.0 (0.18 – 0.24)	0.5 (0.03)
	w/ BACS	Minus 12.5 – 22.5°	350	49 (0.50, 7.1)	200	3.0 – 4.0 (0.18 – 0.24)	0.5 (0.03)

Cold start system	Fuel temperature °C (°F)	Timer piston stroke mm (in.)
	25 (77)	0.47 – 0.67 (0.019 – 0.026)
Fast idle	Fuel temperature °C (°F)	Clearance mm (in.)
	25 (77)	5.5 (0.217)
	50 (122)	0 (0)
Adjusting lever	Lever moving angle	41 – 51°

TORQUE SPECIFICATIONS

Part tightened	N·m	kgf·cm	ft·lbf
Nozzle holder body x Nozzle holder retaining nut	37	375	27
Injection nozzle x Cylinder head	64	650	47
Nozzle leakage pipe x Injection nozzle	30	300	22
Injection pump clamp x Intake manifold	6	65	56 in·lbf
Injection pipe x Injection nozzle	15	150	11
Injection pipe x Injection pump	15	150	11
Intake pipe x Intake manifold	12	120	9
Fuel inlet hollow screw x Injection pump body	37	375	27
Regulator valve x Injection pump body	8.8	90	78 in·lbf
Feed pump cover x Injection pump body	2.5	25	22 in·lbf
Distributive head x Injection pump body	12	120	9
Governor link support bolt	14	140	10
Delivery valve holder x Distributive head	59	600	43
Distributive head plug x Distributive head	88	900	65
Governor cover x Injection pump body	8.3	85	74 in·lbf
Pickup sensor x Injection pump body	21	210	15
Fuel cut solenoid x Distributive head	22	225	16
Dash pot x Injection pump	11	115	8
Fuel outlet pipe x Injection pump	25	250	18
Fuel inlet pipe x Injection pump	25	250	18
Injection pump x Timing gear case	21	210	15
Pump stay x Injection pump	32	330	24
Pump stay x Cylinder block	32	330	24
Injection pump drive gear x Injection pump	64	650	47
Distributive head plug bolt	25	260	19